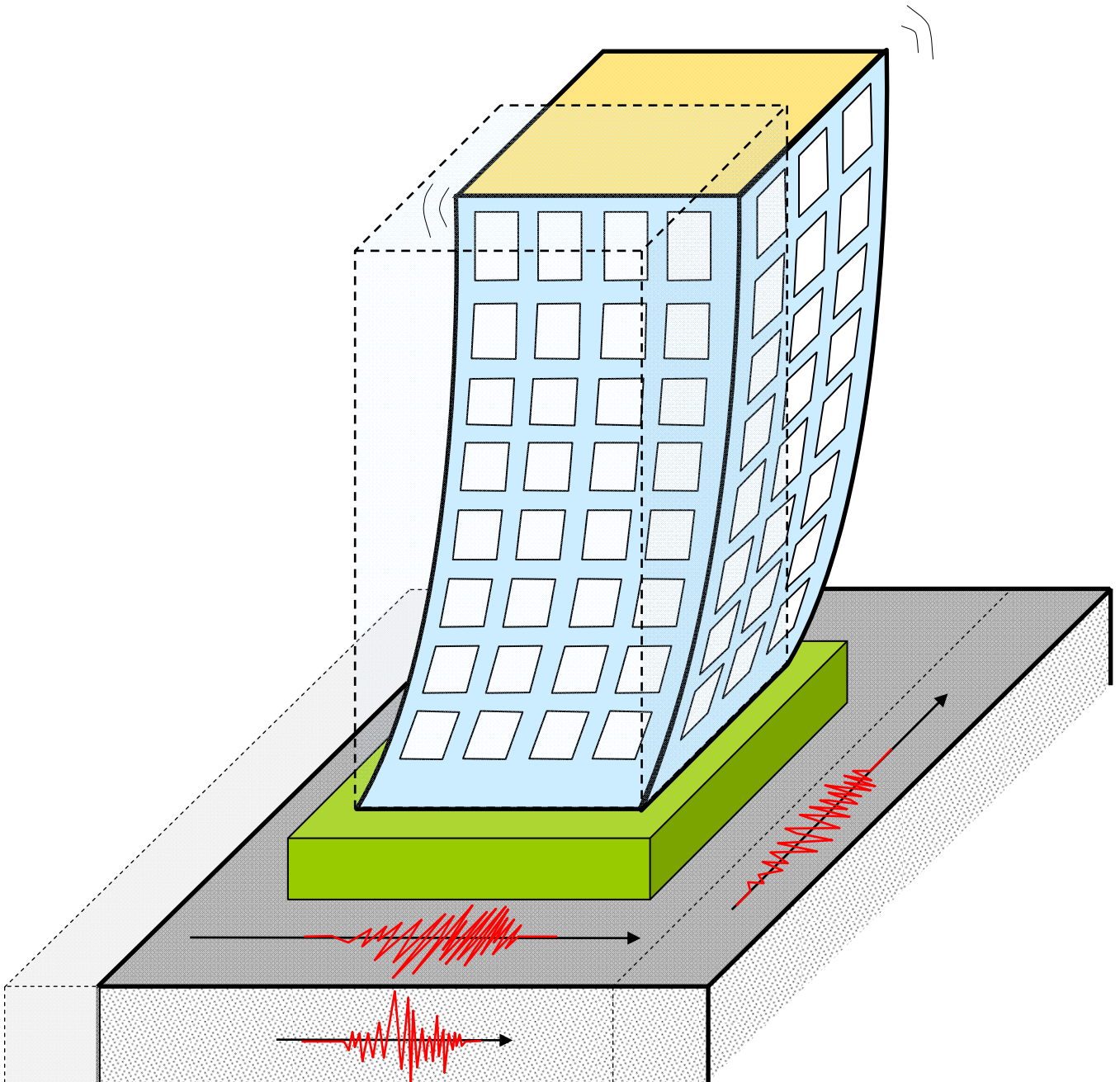


Some Concepts in
Earthquake Behaviour of Buildings

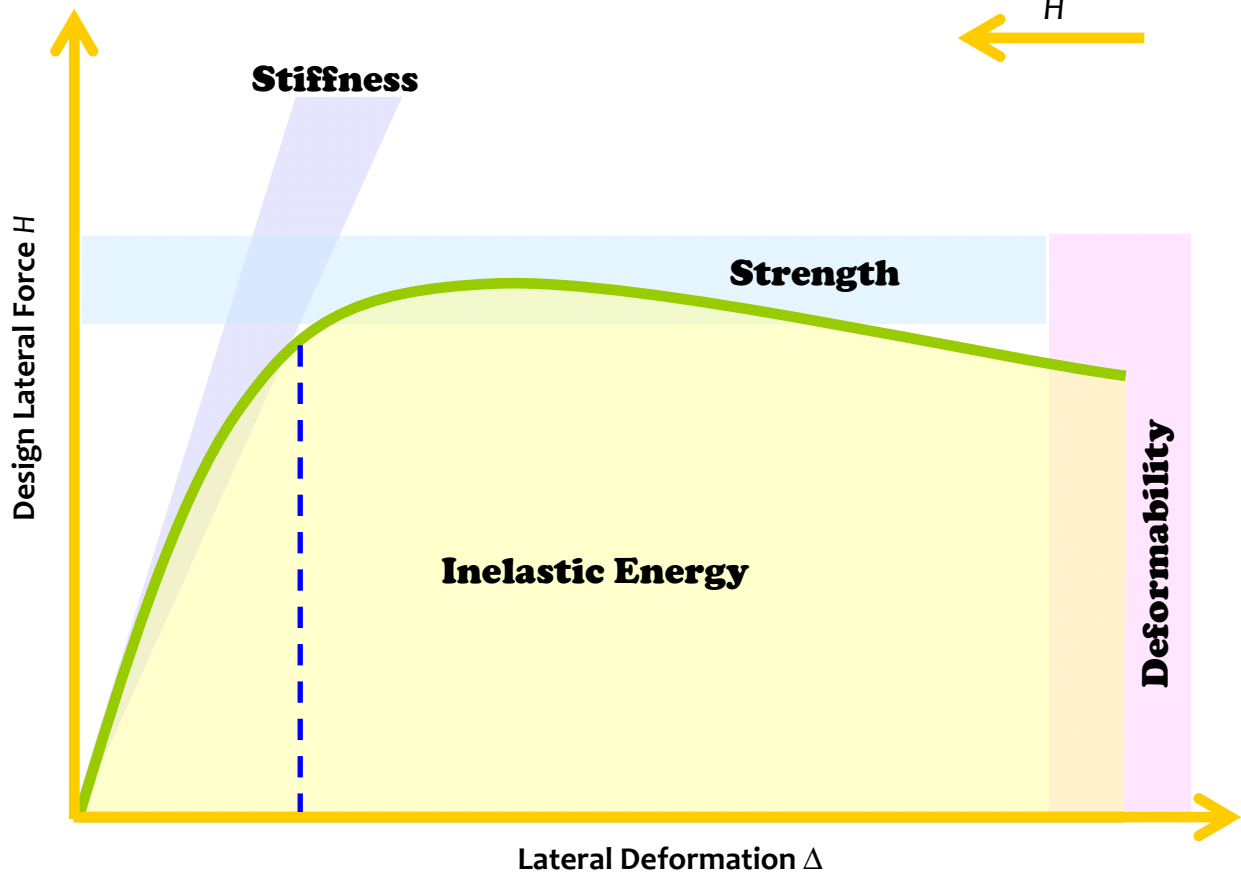
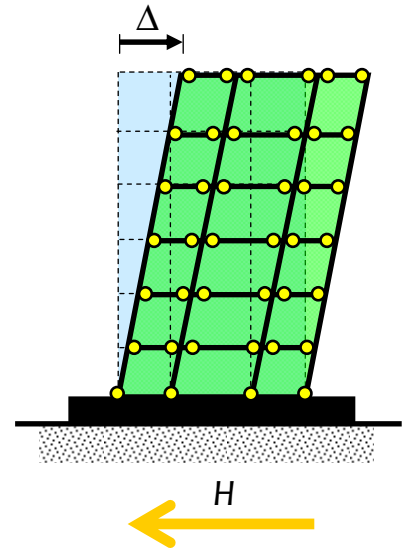


C. V. R. Murty
Rupen Goswami
A. R. Vijayanarayanan
Vipul V. Mehta



Gujarat State Disaster Management Authority
Government of Gujarat

Some Concepts in Earthquake Behaviour of Buildings



C. V. R. Murty
Rupen Goswami
A. R. Vijayanarayanan
Vipul V. Mehta



Gujarat State Disaster Management Authority
Government of Gujarat

Preface

This book explains concepts in *behaviour* of buildings during earthquakes. The book dwells on basic concepts in earthquake resistant design of buildings, first describes these at a conceptual level and then articulates further with numerical examples. It is an attempt to respond to some of the frequently asked questions by *Architects* and *Structural Engineers* regarding behaviour of *Reinforced Concrete (RC)* and *Steel* buildings under the action of lateral loads, especially during earthquakes. Since most buildings built in India are made of RC, the dominant set of examples used is of RC buildings. But, with no loss of generality, the broad concepts discussed in this document are valid for both RC and Steel buildings. Also, the discussion is limited to normal buildings without any special devices, like *base isolation* and other *energy absorbing or dissipating devices*. Also, specialised systems (like post-tensioning slab systems and nuclear power plants) are not in focus.

This book employs *exaggerated deformation shapes* to emphasise deformations, and thereby, to develop the most needed intuition of structural behaviour of buildings during earthquakes and its consequences on earthquake-resistant design. The book contains animations related to behaviour of the various buildings models used in this work. Those readers seeing the electronic copy of this book should make special note of those pages titled **Animation Set ...**, to capture the hyperlinks and reach the said animations.

The target audience of the book is practicing *seismic structural engineers* and *architects*, in addition to *students* and *teachers* of *engineering and architecture colleges* striving to understand *seismic behaviour, analysis and design of buildings*.



Acknowledgements

The authors are grateful to the *Gujarat State Disaster Management Authority (GSDMA)*, Government of Gujarat, Gandhinagar (Gujarat, India), for readily agreeing to support the preparation of this book; the generous financial grant provided by GSDMA towards this effort is gratefully acknowledged. *Ms. Alpa R. Sheth*, Managing Director, Vakil Mehta Sheth Consulting Engineers Private Limited, Mumbai, and *Seismic Advisor, GSDMA, Gandhinagar, Gujarat*, has provided unstinted support to the project. Her technical inputs have been invaluable at all stages of the project - the proposal review, intermediate feedback during development and technical review at the end. The authors are indebted to her for this proactive role in the development of the book, and thank her sincerely for the same. The authors sincerely thank *Mr. Birju Patel*, Deputy Director, GSDMA, Gandhinagar, for timely action and administrative support from GSDMA side.

The authors extend their appreciation to *Dr. R. Bannerji*, IAS, Chief Executive Officer, GSDMA, *Dr. V. Thiruppugazh*, IAS, Additional Chief Executive Officer, GSDMA and *Mr. S. I. Patel*, Additional Chief Executive Officer, GSDMA for their invaluable inputs and guidance during the course of preparing and finalizing this book.

Mr. Arvind Jaiswal, Chief Consulting Engineer, EON Designers and Architects Limited, Secunderabad, read in detail the manuscript of this book and offered critical technical comments; the authors offer him their most sincere gratitude for this special contribution towards improving the usefulness of this book. CSI India, New Delhi, provided the nonlinear structural analysis tools, *e.g., SAP2000, ETABS* and *PERFORM 3D*, to undertake numerical work for the preparation of this book; this contribution is sincerely acknowledged. *Professors Devdas Menon* and *A. Meher Prasad* at IIT Madras provided resources during the early days of the work and offered continued encouragement during the entire course of this work; the authors are indebted to them for this affection and support. M.Tech. (Civil Engineering) students at IIT Madras, *Mr. Deepan Shanmugasundaram*, *Mr. Arun Mathews* and *Mr. K. Rajgopal*, prepared the input files for many building analyses as part of their research assistantship; their contribution is sincerely acknowledged. The authors acknowledge with thanks the support offered by various sections of IIT Madras in administering this book writing project. In particular, the authors gratefully acknowledge support offered by *Mrs. S. Kavita*, Project Assistant, Department of Civil Engineering, and of *Mrs. C. Sankari* and *Mr. Anand Raj* of the Structural Engineering Laboratory of the Institute.

The authors remain indebted to their parents and family members for the unconditional support and understanding throughout the development of the book... This book is dedicated to all the people of India, who lost their lives in *RC building collapses* during past earthquakes in the country...



Contents

	<i>page</i>
<i>Preface</i>	<i>iii</i>
<i>Acknowledgments</i>	<i>v</i>
<i>Contents</i>	<i>vii</i>
<i>Symbols</i>	<i>x</i>
1 Earthquake-Resistant Buildings	
1.1 Basics of Earthquake-Resistant Design and Construction	1
1.2 Basic Aspects of Seismic Design	2
1.3 The Four Virtues of Earthquake Resistant Buildings	5
1.3.1 Characteristics of Buildings	5
(a) Seismic Structural Configuration	5
(b) Structural Stiffness, Strength and Ductility	8
1.3.2 What are the Four Virtues?	9
(a) Who Controls the Four Virtues?	9
(b) How to Achieve the Four Virtues?	10
1.4 Earthquake Demand versus Earthquake Capacity	10
1.5 Force-based Design to Displacement-based Design	13
2 Earthquake Demand on Buildings	
2.1 Seismic Design Force	15
2.2 Dynamic Characteristics of Buildings	18
2.2.1 Natural Period	18
(a) Fundamental Natural Period of Building	19
(b) Factors influencing Natural Period	20
(1) Effect of Stiffness	21
(2) Effect of Mass	22
(3) Effect of Building Height	23
(4) Effect of Column Orientation	24
(5) Effect of Unreinforced Masonry Infill Walls in RC Frames	24
(6) Effect of Cracked Sections on Analysis of RC Frames	25
(c) Design Practice	27
2.2.2 Mode Shape	29
(a) Fundamental Mode Shape of Oscillation	29
(b) Factors influencing Mode Shapes	32
(1) Effect of Flexural Stiffness of Structural Elements	32
(2) Effect of Axial Stiffness of Vertical Members	34
(3) Effect of Degree of Fixity at Member Ends	36
(4) Effect of Building Height	38
(5) Effect of Unreinforced Masonry Infill Walls in RC Frames	40
(c) Design Practice	44
2.2.3 Damping	45
2.3 Ground Motion Characteristics	47
2.3.1 Accelerograms	47
2.3.2 Response Spectrum of a Ground Motion	49
(a) Acceleration Response Spectrum of a Ground Motion	51
(b) Design Practice	52

3 Earthquake Capacity of Buildings – Elastic Behaviour		
3.1	Elastic Behaviour	53
3.2	Configuration	53
	3.2.1 Overall Geometry	53
	(a) Plan Shape	53
	(1) Buildings with different shapes, but same Plan Area	54
	(2) Buildings with different projections, but same Plan Shape	64
	(b) Plan Aspect Ratio	71
	(1) Buildings with distributed LLRS in plan and cut-outs	74
	(2) Buildings with regular plan shape, but of large plan size and with cut-outs	79
	(c) Slenderness Ratio	81
	3.2.2 Structural Systems and Components	83
	(a) Moment Frame Systems	84
	(b) Structural Wall-Frame Systems	94
	(c) Braced Frame Systems	99
	(d) Tube System	103
	(e) Tube-in-Tube and Bundled Tube Systems	109
	(f) Flat Slab Building	117
	3.2.3 Load Paths	121
	(a) Frames	124
	(b) Structural Walls	128
3.3	Mass	134
	3.3.1 Mass Asymmetry in Plan	134
	3.3.2 Mass Irregularity in Elevation	135
3.4	Initial Stiffness	137
	3.4.1 Stiffness Irregularity in Plan	137
	3.4.2 Stiffness Irregularity in Elevation	143
	(a) Open or Flexible Storey in Buildings	143
	(b) Plinth and Lintel Beams in Buildings	147
	(c) Buildings on Slope	151
	(d) Set-back and Step-back Buildings	155
	3.4.3 Adjacency	161
	3.4.4 Soil Flexibility	167
4 Earthquake Capacity of Buildings – Inelastic Behaviour		
4.1	Inelastic Behaviour	173
4.2	Strength	173
	4.2.1 Strength Hierarchy	174
	(a) Beam-Column Joints	180
	4.2.2 Structural Plan Density	183
	4.2.3 Strength Asymmetry in Plan	186
	4.2.4 Strength Discontinuity in Elevation	190
	(a) Open/ Flexible/ Weak Storeys in a Building	192
	(b) Discontinuous Structural Walls in a Building	196
	(c) Short Column Effect	200
4.3	Ductility	205
	4.3.1 Definitions of Ductility	205
	(a) Contributors to Ductility in Reinforced Concrete Buildings	205
	(b) Achieving Ductility in Reinforced Concrete Buildings	216
	(c) Assessing Ductility available in Buildings	216
	4.3.2 Strength Provided in Building and Overall Ductility Demand	220

	<i>page</i>
4.3.3 Capacity Design of Buildings	222
(a) Displacement Loading	222
(b) Capacity Design Concept	224
4.3.4 Distribution of Damage in Buildings	227
(a) The Open Ground Storey Buildings	228
(b) Strong Column - Weak Beam Design	232
(c) Excessive ductility demands owing to Pounding from Adjacent Building / Adjacent Part of same Building	237
4.4 Modeling of Buildings	238
5 Earthquake-Resistant Design of Buildings	
5.1 Introduction	241
5.2 Earthquake-Resistant Design Methods	245
5.3 Earthquake-Resistant Design Procedure	247
5.3.1 Stiffness Design Stage	247
5.3.2 Strength Design Stage	249
5.3.3 Ductility Design Stage	250
5.4 Closing Comments	250
 <i>Bibliography</i>	 251

Symbols

$a_g(t)$	Ground acceleration
f_c	Grade of concrete
f_n	n^{th} Fundamental natural frequency of building
m	Seismic mass
u_u	Ultimate plastic displacement of a frame member in tension/compression
u_y	Idealized yield displacement of a frame member in tension/compression
v_u	Ultimate plastic shear displacement
v_y	Idealised yield shear displacement
A_g	Gross cross-sectional area of RC section
A_h	Design horizontal base shear coefficient
A_s	Area resisting shear
B	Breadth of building
E	Modulus of elasticity
F_w	Lateral force
G	Shear modulus
H	Height of building
H	Lateral base shear force of the building
H_{max}	Peak lateral strength
I	Importance factor
$I_{b,eff}$	Effective moment of inertia of beam
$I_{b,gross}$	Gross moment of inertia of beam
I_b	Moment of inertia of a beam
I_c	Moment of inertia of a column
$I_{c,eff}$	Effective moment of inertia of a cracked RC column
$I_{c,gross}$	Gross moment of inertia of an un-cracked RC column
I_g	Gross moment of Inertia of an RC section
K	Initial lateral stiffness
L	Length of building
D	Depth of a frame member
L	Length of a frame member
M_{bD}	Design flexural moment capacity of beam
$M_{b\Omega}$	Overstrength flexural moment capacity of beam
M_{cD}	Design flexural moment capacity of column
M_p	Plastic moment capacity of a frame member
M_Ω	Maximum overstrength-based plastic moment capacity of a frame member
P	Axial load applied on of a frame member
P_{cr}	Critical axial load of a frame member
P_{uz}	Design axial load capacity of column in pure axial compression
R	Response Reduction Factor
R_μ	Strength Ratio
S_d/g	Design acceleration spectrum value
T	Fundamental translational natural period of the building
T_n	n^{th} Fundamental natural period of the building
T_{x1}	Fundamental translational natural period along X-direction
T_{y1}	Fundamental translational natural period along Y-direction
T_{z1}	Fundamental vertical natural period along Z-direction
$T_{\theta 1}$	Fundamental torsional natural period about Z-axis
V_B	Design base shear
V_{jh}	Horizontal shear force in beam-column joint
V_{jv}	Vertical shear force in beam-column joint
V_n	Nominal shear capacity of RC section

V_{Ω}	Maximum overstrength-based equilibrium compatible shear demand
W	Seismic weight of building
Z	Seismic Zone Factor
Z_p	Plastic Section Modulus
β	Ratio of pure flexural translational stiffness to pure shear translational stiffness
δ	Imposed deformation during earthquake
θ_u	Ultimate rotational capacity
θ_y	Idealized yield rotation
μ	Material ductility
μ_m	Member ductility
μ_s	Structure ductility
ν	Poisson ratio
ξ	Damping
σ_{cr}	Critical axial stress in compression
Ω_s	Overstrength factor for steel bars
Δ_{max}	Maximum lateral deformation
Δ_{Roof}	Displacement at roof level
Δ_Y	Idealized yield deformation

Chapter 1

Earthquake-Resistant Buildings

1.1 DYNAMIC ACTIONS ON BUILDINGS – WIND *versus* EARTHQUAKE

Dynamic actions are caused on buildings by both *wind* and *earthquakes*. But, design for wind forces and for earthquake effects are distinctly different. The intuitive philosophy of structural design uses *force* as the basis, which is consistent in wind design, wherein the building is subjected to a *pressure* on its exposed surface area; this is *force-type* loading. However, in earthquake design, the building is subjected to random motion of the ground at its base (Figure 1.1), which induces inertia forces in the building that in turn cause stresses; this is *displacement-type* loading. Another way of expressing this difference is through the load-deformation curve of the building – the demand on the building is *force* (i.e., *vertical axis*) in force-type loading imposed by wind pressure, and *displacement* (i.e., *horizontal axis*) in displacement-type loading imposed by earthquake shaking.

Wind force on the building has a non-zero mean component superposed with a relatively small oscillating component (Figure 1.2). Thus, under wind forces, the building may experience small fluctuations in the stress field, but reversal of stresses occurs only when the direction of wind reverses, which happens only over a large duration of time. On the other hand, the motion of the ground during the earthquake is cyclic about the neutral position of the structure. Thus, the stresses in the building due to seismic actions undergo many complete reversals and that too over the small duration of earthquake.

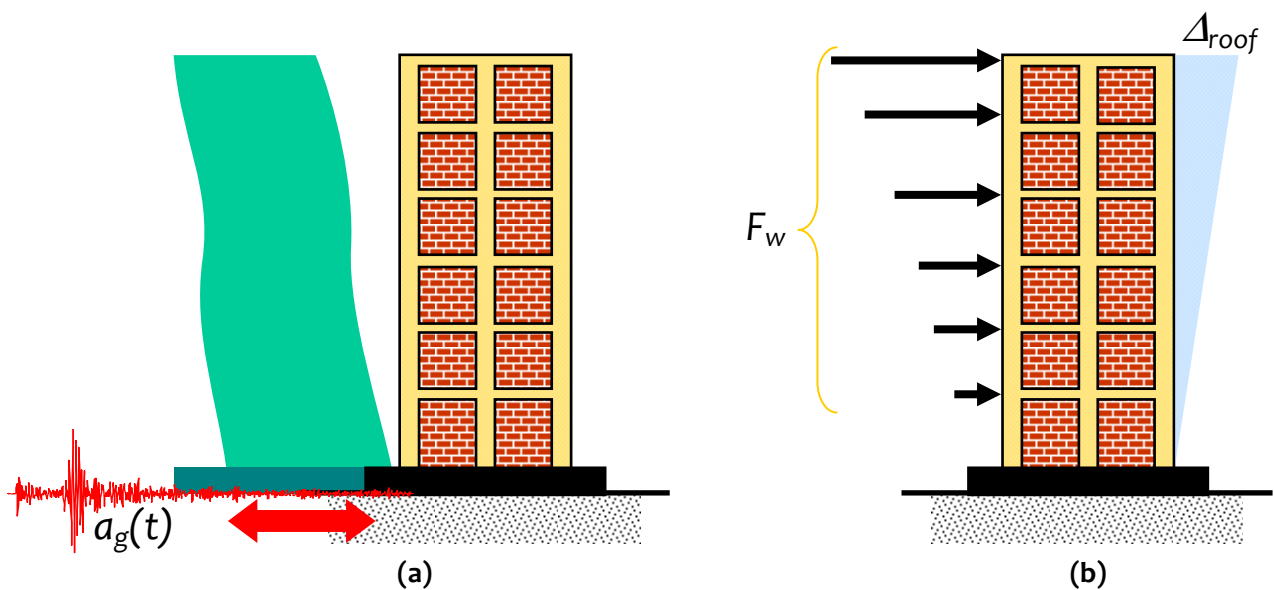


Figure 1.1: Difference in the design effects on a building during natural actions of (a) Earthquake Ground Movement at base, and (b) Wind Pressure on exposed area

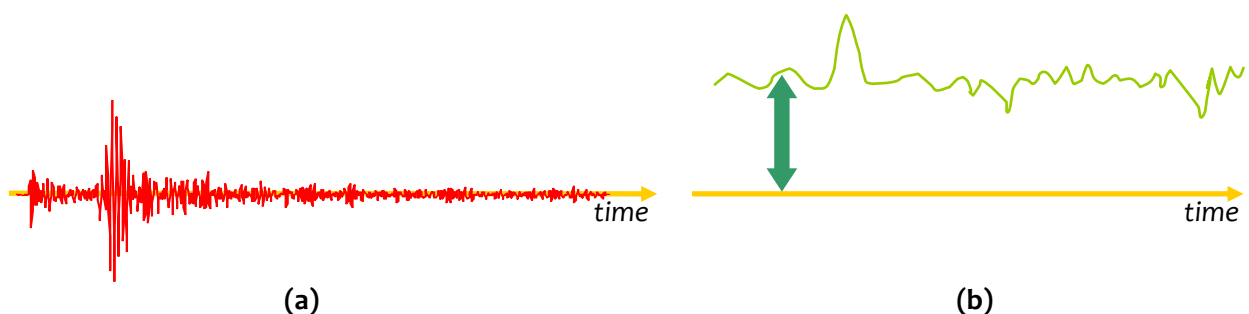


Figure 1.2: Nature of temporal variations of design actions: (a) Earthquake Ground Motion – zero mean, cyclic, and (b) Wind Pressure – non-zero mean, oscillatory

1.2 BASIC ASPECTS OF SEISMIC DESIGN

The *mass* of the building being designed controls seismic design in addition to the building *stiffness*, because earthquake induces *inertia forces* that are proportional to the building mass. Designing buildings to behave elastically during earthquakes without damage may render the project economically unviable. As a consequence, it may be necessary for the structure to undergo damage and thereby dissipate the energy input to it during the earthquake. Therefore, the traditional *earthquake-resistant design* philosophy requires that normal buildings should be able to resist (Figure 1.3):

- (a) *Minor (and frequent) shaking* with no damage to structural and non-structural elements;
- (b) *Moderate shaking* with minor damage to structural elements, and some damage to non-structural elements; and
- (c) *Severe (and infrequent) shaking* with damage to structural elements, but with NO collapse (to save life and property inside/adjoining the building).

Therefore, buildings are designed only for a fraction (~8-14%) of the force that they would experience, if they were designed to remain elastic during the expected strong ground shaking (Figure 1.4), and thereby permitting damage (Figure 1.5). But, sufficient initial stiffness is required to be ensured to avoid structural damage under minor shaking. Thus, seismic design balances reduced cost and acceptable damage, to make the project viable. This careful balance is arrived based on extensive research and detailed post-earthquake damage assessment studies. A wealth of this information is translated into precise seismic design provisions. In contrast, structural damage is not acceptable under design wind forces. For this reason, design against earthquake effects is called as *earthquake-resistant design* and not *earthquake-proof design*.

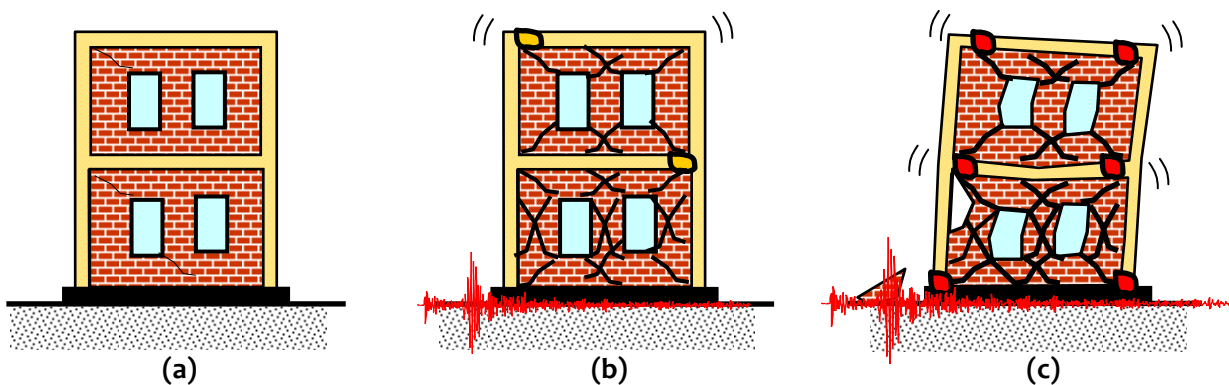


Figure 1.3: Earthquake-Resistant Design Philosophy for buildings: (a) Minor (Frequent) Shaking – No/Hardly any damage, (b) Moderate Shaking – Minor structural damage, and some non-structural damage, and (c) Severe (Infrequent) Shaking – Structural damage, but NO collapse

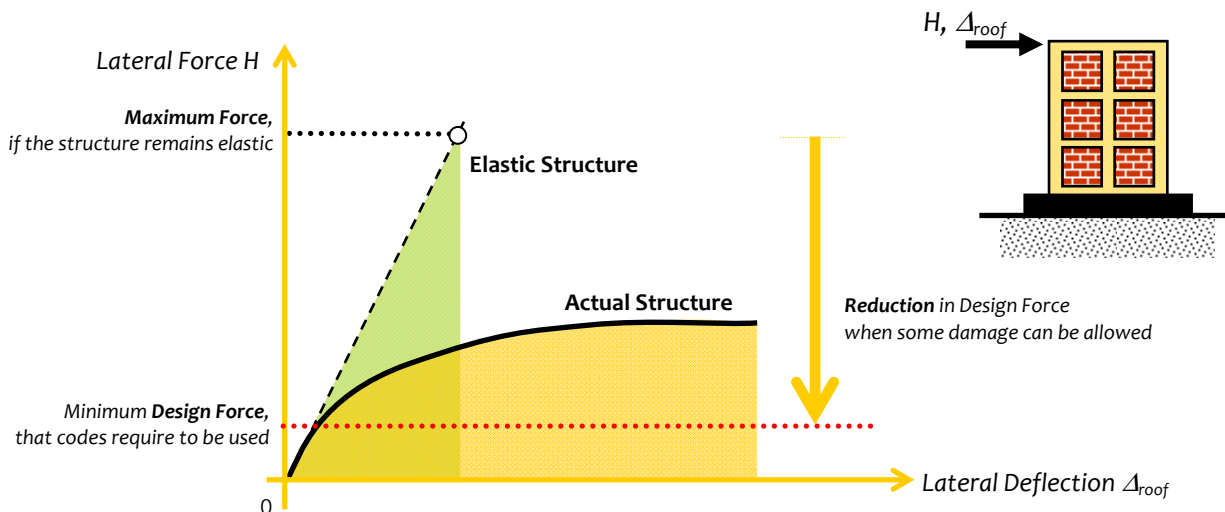


Figure 1.4: Basic strategy of earthquake design: Calculate maximum elastic forces and reduce by a factor to obtain design forces.

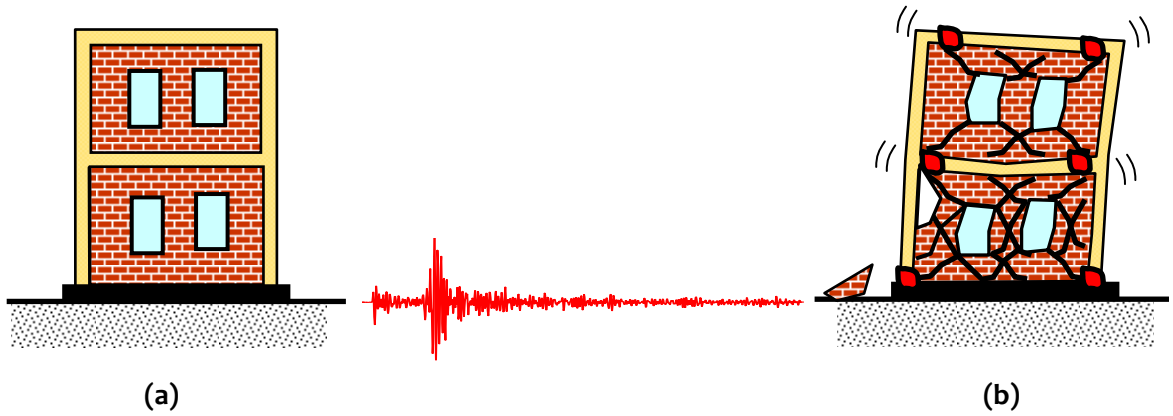


Figure 1.5: *Earthquake-Resistant* and NOT *Earthquake-Proof*: Damage is expected during an earthquake in normal constructions (a) undamaged building, and (b) damaged building.

The design for only a fraction of the elastic level of seismic forces is possible, only if the building can stably withstand large displacement demand through structural damage without collapse and undue loss of strength. This property is called *ductility* (Figure 1.6). It is relatively simple to design structures to possess certain lateral strength and initial stiffness by appropriately proportioning the size and material of the members. But, achieving sufficient ductility is more involved and requires extensive laboratory tests on full-scale specimen to identify preferable methods of detailing.

In summary, the loading imposed by earthquake shaking under the building is of *displacement-type* and that by wind and all other hazards is of *force-type*. Earthquake shaking requires buildings to be capable of resisting certain relative displacement within it due to the imposed displacement at its base, while wind and other hazards require buildings to resist certain level of force applied on it (Figure 1.7a). While it is possible to estimate with precision the maximum force that can be imposed on a building, the maximum displacement imposed under the building is not as precisely known. For the same maximum displacement to be sustained by a building (Figure 1.7b), wind design requires only *elastic* behaviour in the entire range of displacement, but in earthquake design there are two options, namely design the building to remain elastic or to undergo inelastic behaviour. The latter option is adopted in normal buildings, and the former in special buildings, like critical buildings of nuclear power plants.

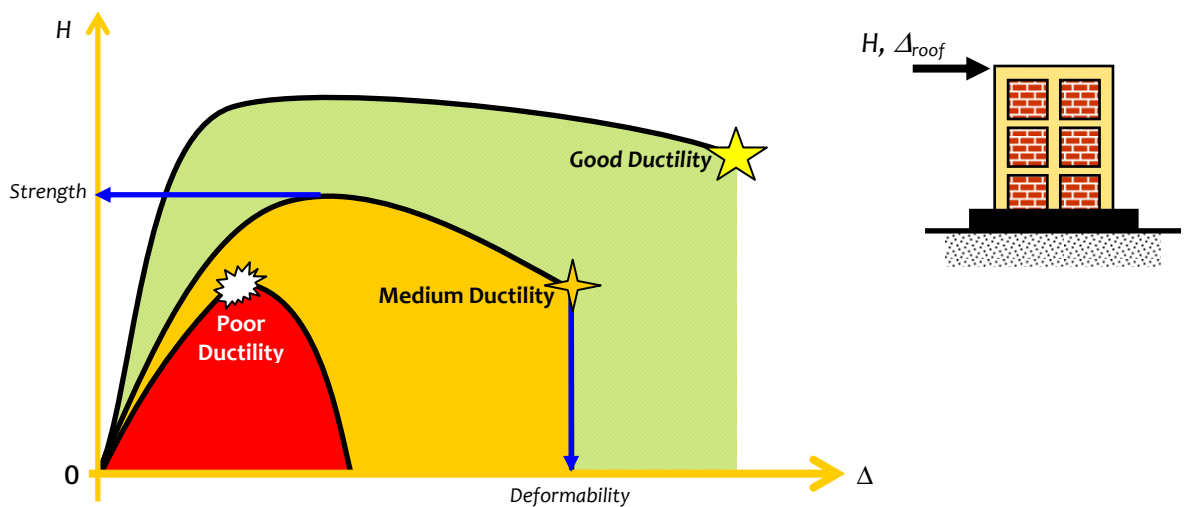
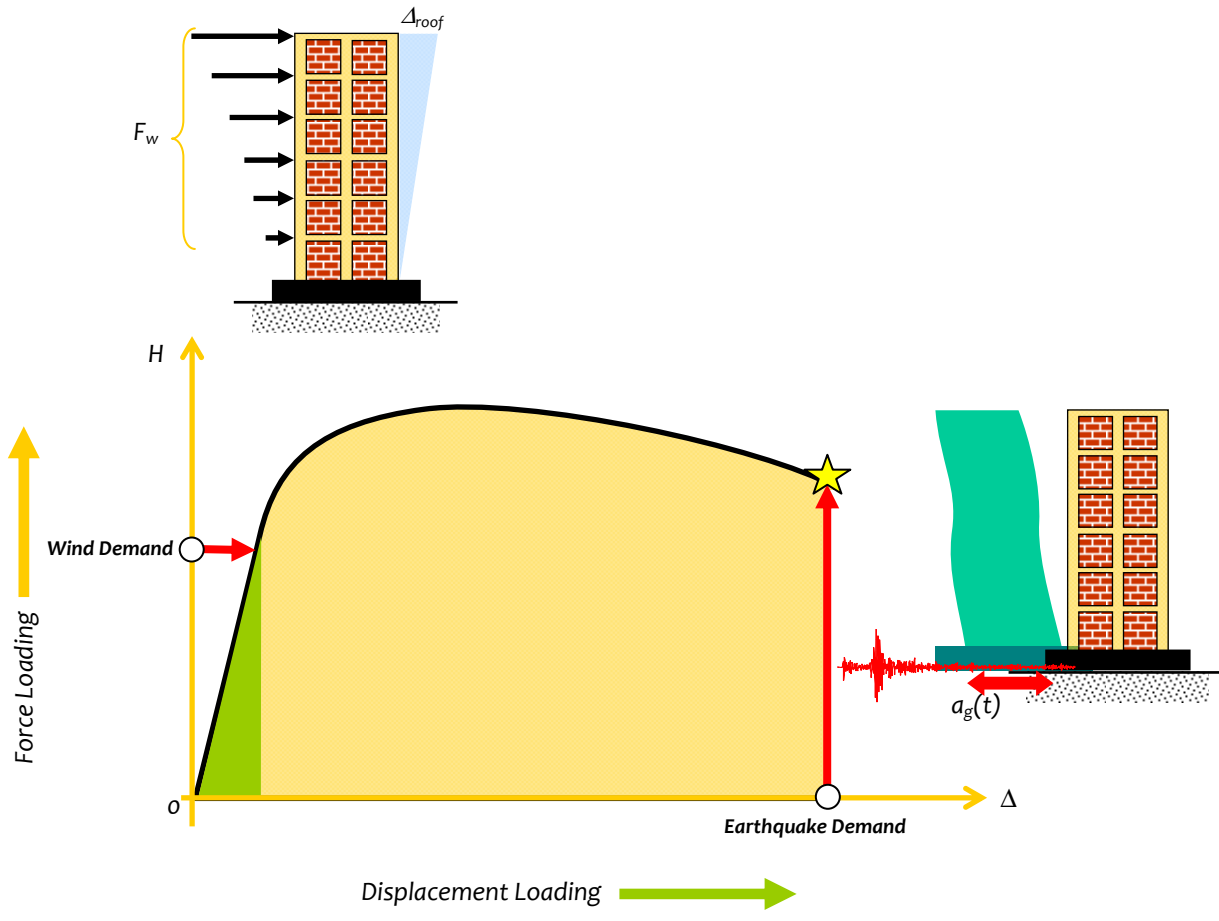
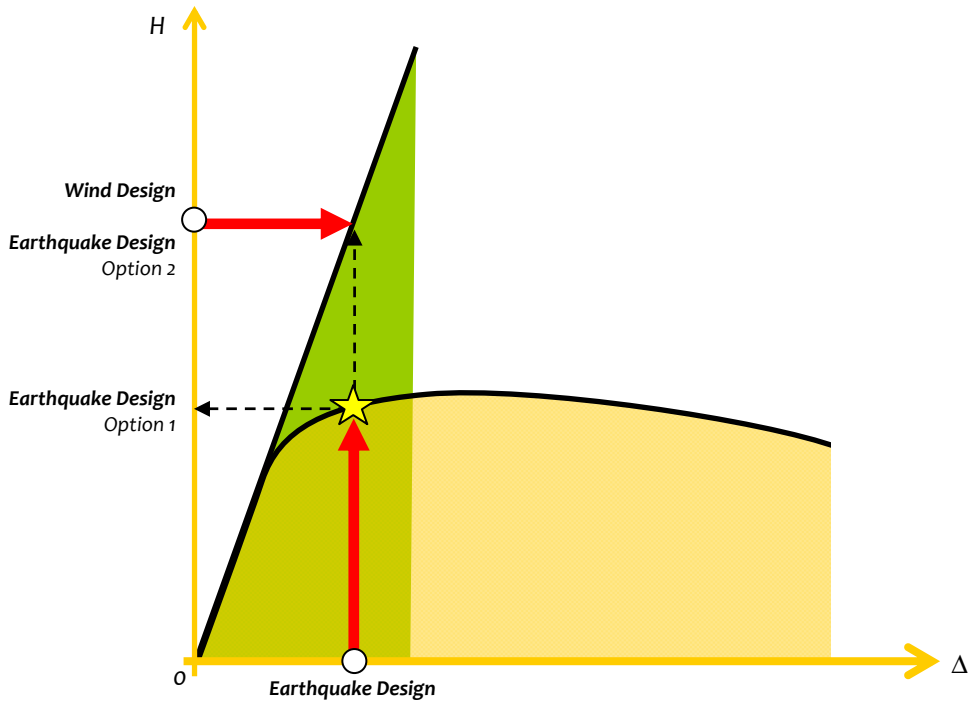


Figure 1.6: *Ductility*: Buildings are designed and detailed to develop favorable failure mechanisms that possess specified lateral strength, reasonable stiffness and, above all, good post-yield deformability.



(a)



(b)

Figure 1.7: Displacement Loading versus Force Loading: Earthquake shaking imposes displacement loading on the building, while all other hazards impose force loading on it

1.3 THE FOUR VIRTUES OF EARTHQUAKE RESISTANT BUILDINGS

For a building to perform satisfactorily during earthquakes, it must meet the philosophy of *earthquake-resistant* design discussed in Section 1.2.

1.3.1 Characteristics of Buildings

There are four aspects of buildings that architects and design engineers work with to create the earthquake-resistant design of a building, namely *seismic structural configuration*, *lateral stiffness*, *lateral strength* and *ductility*, in addition to other aspects like form, aesthetics, functionality and comfort of building. Lateral stiffness, lateral strength and ductility of buildings can be ensured by strictly following most seismic design codes. But, good seismic structural configuration can be ensured by following coherent architectural features that result in good structural behaviour.

(a) Seismic Structural Configuration

Seismic structural configuration entails three main aspects, namely (a) geometry, shape and size of the building, (b) location and size of structural elements, and (c) location and size of significant non-structural elements (Figure 1.8). Influence of the geometry of a building on its earthquake performance is best understood from the basic geometries of *convex* and *concave* lenses from school-day physics class (Figure 1.9). The line joining any two points within area of the convex lens, lies completely within the lens. But, the same is not true for the concave lens; a part of the line may lie outside the area of the concave lens. Structures with *convex* geometries are preferred to those with concave geometries, as the former demonstrate superior earthquake performance. In the context of buildings, convex shaped buildings have direct load paths for transferring earthquake shaking induced inertia forces to their bases for any direction of ground shaking, while concave buildings necessitate bending of load paths for shaking of the ground along certain directions that result in stress concentrations at all points where the load paths bend.

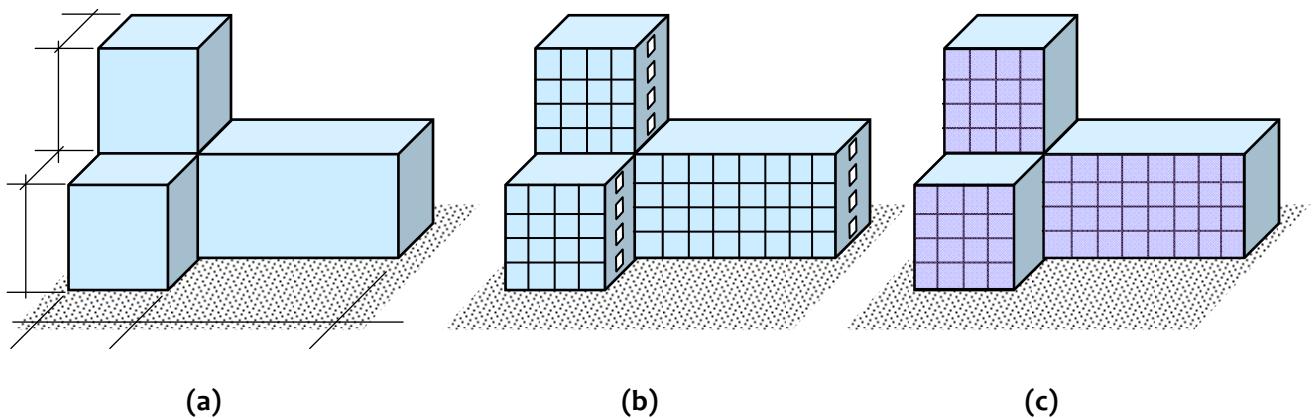
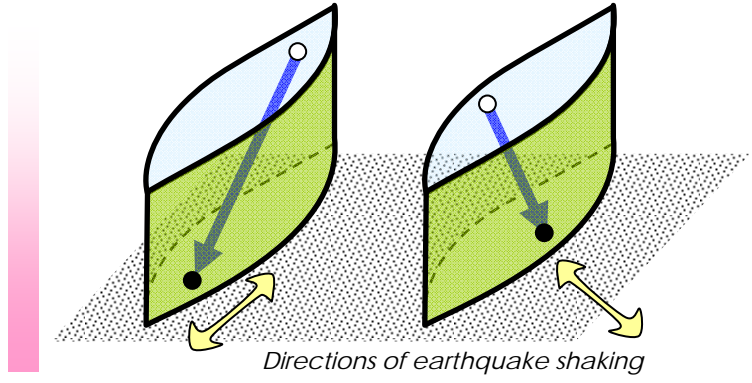
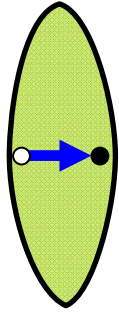
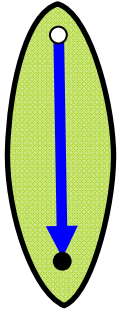
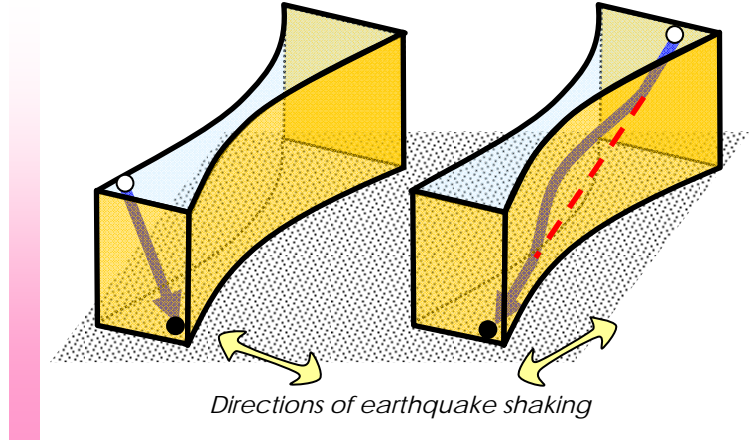
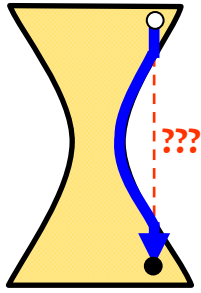
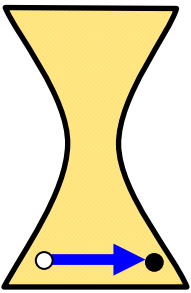


Figure 1.8: Components of seismic structural configuration: (a) overall geometry, (b) structural elements (e.g., moment resisting frames and structural walls), and (c) significant non-structural elements (e.g., façade glass)



(a)



(b)

Figure 1.9: Basic forms of seismic structural configuration: Two geometries of architectural forms (a) convex, and (b) concave

Based on the above discussion, normally built buildings can be placed in two categories, namely *simple* and *complex* (Figure 1.10). Buildings with rectangular plans and straight elevation stand the best chance of doing well during an earthquake, because inertia forces are transferred without having to bend due to the geometry of the building (Figure 1.10a). But, buildings with setbacks and central openings offer geometric constraint to the flow of inertia forces; these inertia force paths have to bend before reaching the ground (Figure 1.10b, 10c)

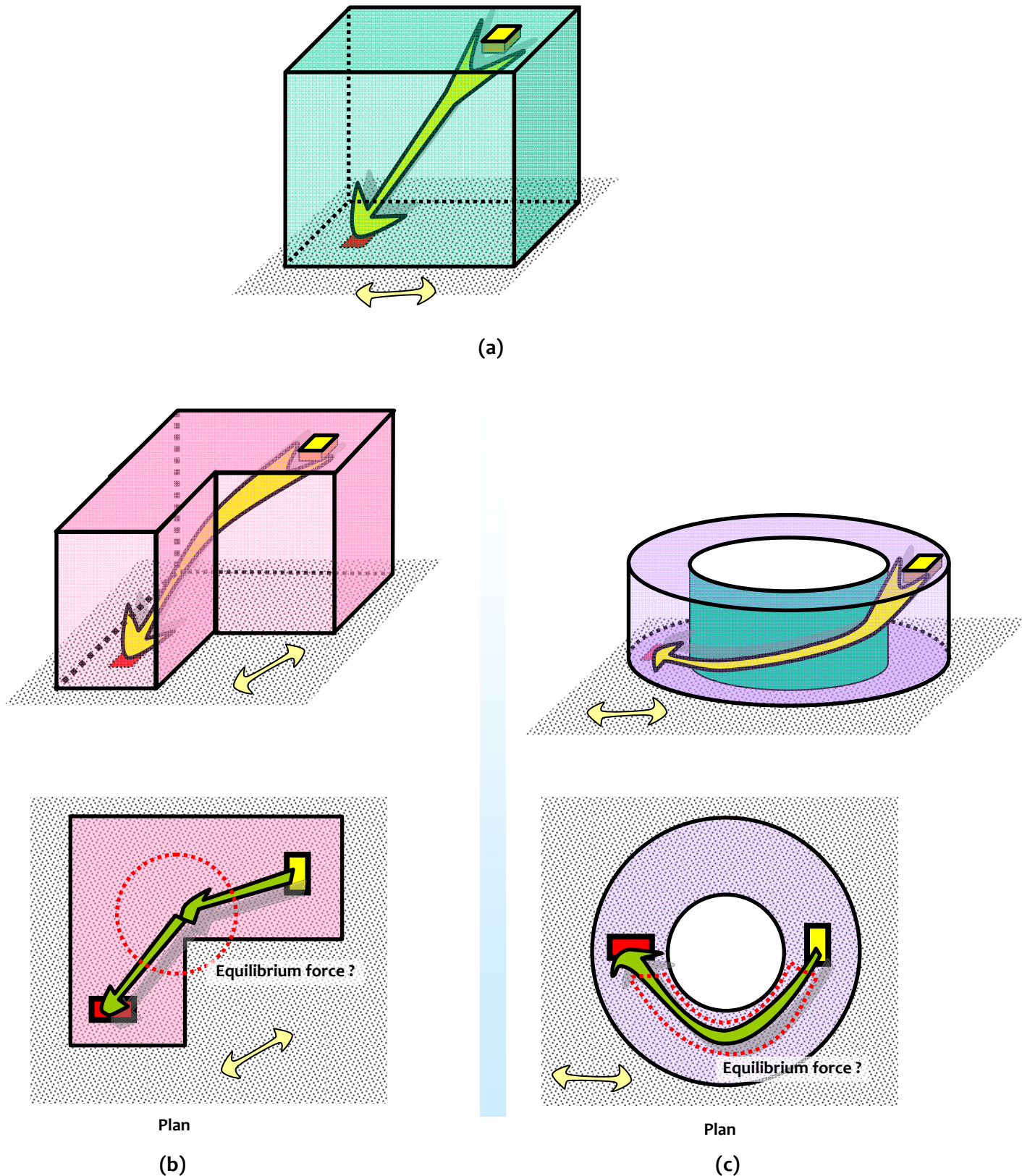


Figure 1.10: Classification of buildings: (a) Simple, and (b), (c) Complex

(b) Structural Stiffness, Strength and Ductility

The next three overall properties of a building, namely *lateral stiffness*, *lateral strength* and *ductility*, are illustrated in Figure 1.11, through the *lateral load - lateral deformation* curve of the building. *Lateral stiffness* refers to the *initial stiffness* of the building, even though stiffness of the building reduces with increasing damage. *Lateral strength* refers to the maximum resistance that the building offers during its entire history of resistance to relative deformation. *Ductility* towards lateral deformation refers the ratio of the maximum deformation and the idealised yield deformation. The maximum deformation corresponds to the maximum deformation sustained by it, if the load-deformation curve does not drop, and to 85% of the ultimate load on the dropping side of the load-deformation response curve after the peak strength or the lateral strength is reached, if the load-deformation curve does drop after reaching peak strength.

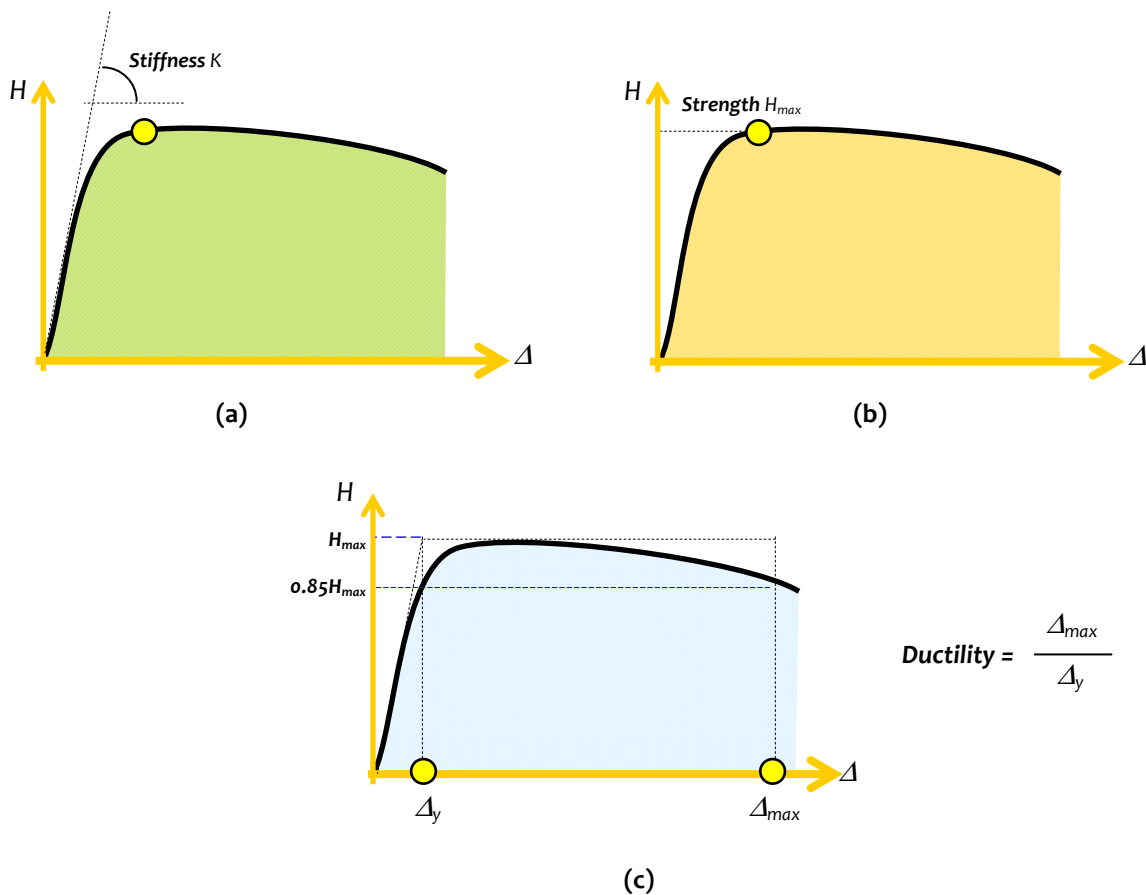


Figure 1.11: Structural Characteristics: Overall load deformation curves of a building, indicating (a) lateral stiffness, (b) lateral strength, and (c) ductility towards lateral deformation

1.3.2 What are the Four Virtues?

All buildings are vertical cantilevers projecting out from the earth's surface. Hence, when the *earth shakes*, these cantilevers experience whiplash effects, especially when the shaking is violent. Hence, special care is required to protect them from this jerky movement. Buildings intended to be earthquake-resistant have competing demands. Firstly, buildings become expensive, if designed not to sustain any damage during strong earthquake shaking. Secondly, they should be strong enough to not sustain any damage during weak earthquake shaking. Thirdly, they should be stiff enough to not swing too much, even during weak earthquakes. And, fourthly, they should not collapse during the expected strong earthquake shaking to be sustained by them even with significant structural damage. These competing demands are accommodated in buildings intended to be *earthquake-resistant* by incorporating four *desirable* characteristics in them. These characteristics, called the *four virtues of earthquake-resistant buildings*, are:

1. Good *seismic configuration*, with no choices of architectural form of the building that is detrimental to good earthquake performance and that does not introduce newer complexities in the building behaviour than what the earthquake is already imposing;
2. At least a minimum *lateral stiffness* in each of its plan directions (uniformly distributed in both plan directions of the building), so that there is no discomfort to occupants of the building and no damage to contents of the building;
3. At least a minimum *lateral strength* in each of its plan directions (uniformly distributed in both plan directions of the building), to resist low intensity ground shaking with no damage, and not too strong to keep the cost of construction in check, along with a minimum *vertical strength* to be able to continue to support the gravity load and thereby prevent collapse under strong earthquake shaking; and
4. Good overall *ductility* in it to accommodate the imposed lateral deformation between the base and the roof of the building, along with the desired mechanism of behaviour at ultimate stage.

Behaviour of buildings during earthquakes depend critically on these four virtues. Even if any one of these is not ensured, the performance of the building is expected to be poor.

(a) Who Controls the Four Virtues?

Henry Degenkolb, a noted earthquake engineer of USA, aptly summarized the immense importance of seismic configuration in his words: "*If we have a poor configuration to start with, all the engineer can do is to provide a band-aid - improve a basically poor solution as best as he can. Conversely, if we start-off with a good configuration and reasonable framing system, even a poor engineer can't harm its ultimate performance too much.*" Likewise, Nathan M. Newmark and Emilo Rosenbleuth, eminent Professors of Earthquake Engineering in USA and Mexico, respectively, batted for the concepts of earthquake-resistant design in their foreword to their book: "*If a civil engineer is to acquire fruitful experience in a brief span of time, expose him to the concepts of earthquake engineering, no matter if he is later not to work in earthquake country.*"

In many countries, like India, in the design of a *new building*, the *architect* is the team leader, and the engineer a team member. And, in the design of *retrofit of an existing building*, the *engineer* is the team leader, and the architect a team member. What is actually needed is that both the architect and the engineer work *together* to create the best design with good interaction at all stages of the process of the design of the building. Here, the architect brings in perspectives related to *form, functionality, aesthetics* and *contents*, while the engineer brings the perspectives of *safety* and *desired earthquake performance* during an expected earthquake. There is a two way influence of the said parameters handled both by the architect and by the engineer; their work has to be in unison.

(b) How to Achieve the Four Virtues?

The four virtues are achieved by inputs provided at all stages of the development of the building, namely in its *planning, design, construction* and *maintenance*. Each building to be built is only one of the kind ever, and no research and testing is performed on that building, unlike factory-made products like aircrafts, ships and cars. The owner of the building *trusts* the professionals (*i.e.*, architect and engineer) to have done due diligence to design and construct the building. Thus, professional experience is essential to be able to conduct a safe design of the building, because it affects the safety of persons and property.

Traditionally, in countries that have advanced earthquake safety initiatives, governments have played critical role through the enforcement of techno-legal regime, wherein the municipal authorities arrange to examine, if all requisite technical inputs have been met with to ensure safety in the building, before allowing the building to be built, the construction to be continued at different stages, or the users to occupy the building. These stages are: (1) conceptual design stage, (2) design development stage through peer review of the structural design, (3) construction stage through quality control and quality assurance procedures put in place. Senior professionals (both architects and engineers) are required to head the team of professionals to design a building; these senior professionals should have past experience of having designed buildings to resist strong earthquakes under the tutelage of erstwhile senior professionals.

1.4 EARTHQUAKE DEMAND VERSUS EARTHQUAKE CAPACITY

Unlike all other loading effects, *e.g.*, wind loads, wave loads (excluding tsunami loads), blast loads, snow loads, imposed (live) loads and dead loads, earthquake shaking is the most severe, because it imposes displacement under the building, which is time varying. This, in turn, demands lateral deformation in the building between its base and upper elevations. Higher is the seismic zone, larger is the severity of this imposed relative deformation (Figure 1.12). Therefore, the main challenge is to meet the *double demand* – the building should be able to withstand this imposed deformation *with damage* under small intensity shaking, and *with no collapse* under high intensity shaking. The building needs to possess large inelastic deformation capacity and needs to have the strength in all its members to sustain the forces and moments induced in them.

The method of design of buildings should therefore take into account the deformation *demand* on the building, and the deformation *capacity* of the building. The former depends on the seismo-tectonic setting of the location of the building, but the later is within the control of the design professionals (*i.e.*, architects and engineers). The concern is that both of these quantities have uncertainties. On one hand, even though some understanding is available on the maximum possible ground displacement at a location, earth scientists are not able to clearly provide the upper bound for these numbers. Each new damaging earthquake has always provided surprises. And, on the other hand, analytical tools are not available to estimate precisely the overall nonlinear behaviour of an as-built structure, and its ultimate deformation capacity.

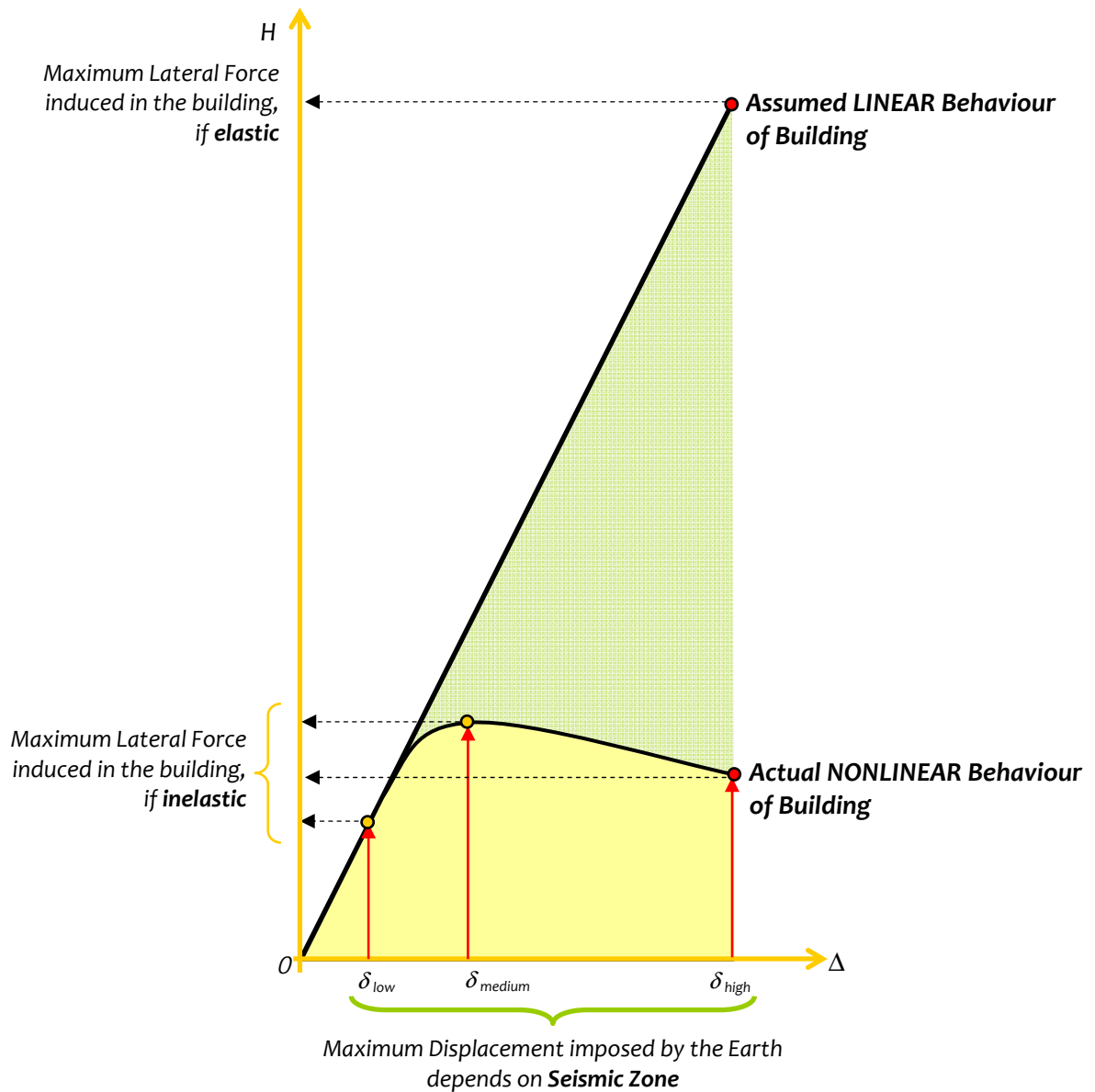


Figure 1.12: Double demand in Buildings subjected to earthquake effects: Need large inelastic deformation capacity in the building and need to sustain the induced forces

On part of the design engineer, a procedure should be employed that is known to result in higher confidence on the structural safety of the building being designed to withstand without collapse during expected severe earthquake shaking and render the requisite post-earthquake performance (*e.g.*, at least a minimum desired ultimate deformation capacity). There are many procedures that are adopted/suggested worldwide [*e.g.*, Goel, 2008]. One structural design procedure includes adherence to the following sequence:

- (1) Arrive at a simple overall geometry of the building for the needed height. Building should be well-proportioned in keeping with the known tenets of acceptable upper limits of overall slenderness ratio and plan aspect ratio, and all the discussions available in earthquake design literature on acceptable seismic structural configurations;
- (2) Adopt a structural system that will resist the vertical and lateral loads offering direct load paths in both plan directions of the building. It is preferable to use structural walls in RC building intended to resist strong earthquake shaking.
- (3) Determine the preliminary sizing of individual structural elements, based on acceptable slenderness ratios and cross-sectional aspect ratios, and minimum reinforcement requirements.

- (4) Identify a desired collapse mechanism in which the building should deform in, under the extreme condition of collapse, if ever, when the earthquake shaking well exceeds the design earthquake shaking for which buildings are normally designed. Usually, in frame structures, plastic moment hinges are desired at the ends of the beams with good rotational ductility. The hinge forms over a small length of the beam, often termed as plastic hinge length; this length depends on the depth, span and end connectivity of the member.
- (5) Prepare a basic structural analysis model of the building with the dimensions and details obtained from preliminary design strategies. Impose a horizontal deformation on the building corresponding to permissible inter-storey drift at all storeys, and perform an elastic analysis of the building. Use concentrated loads at floor levels to push the building by the desired amounts. Note that this step is not usual adopted by common designers. Instead, they apply *design lateral forces*, perform structural analysis, and then design structural elements based on stress-resultants obtained from structural analysis. In the sequence of steps suggested in this structural design procedure, that step appears later as Step 8 below.
- (6) Perform seismic design of all structural elements of the building. For instance, in a moment-resisting frame building:
 1. Design the slabs of the building.
 2. Design beams first for flexure, and then for shear, adopting the capacity design method for design of shear following the desired collapse mechanism identified.
 3. Design all columns and structural walls, to be stronger than the connected beams, first for flexure, and then for shear, adopting the capacity design method for design of shear and following the desired collapse mechanism identified.
 4. Design the beam-to-column, beam-to-wall and slab-to-wall joints.
 5. Design the foundation(s) of the building.
 6. Ensure that the soil underneath is capable of resisting the loads from above under strong strong shaking, and that it remains intact during the said shaking.
- (7) Prepare the improved structural analysis model of the building with the dimensions and details obtained from the design calculations performed above. Estimate the fundamental translational natural period T of the building, and calculate the design seismic base shear V_B on the building.
- (8) Apply the design seismic base shear V_B on the structural analysis model of the building. And, check the adequacy of the design of all structural elements, including beam-column and beam-wall joints.
- (9) Verify, if the desired mechanism is generated in the building through:
 1. Nonlinear quasi-static displacement pushover analysis of the building to begin with, AND then
 2. Nonlinear time-history analysis of the building under different ground motions, whose intensities and spectrum are within the design shaking intensities and design spectrum, respectively.

If the desired mechanism is not achieved, make suitable changes in the design (*i.e.*, choice of the structural system, and/or proportioning of structural members) to achieve the same. The above steps should be repeated for the new design chosen. If the desired mechanism is achieved, requisite *ductile detailing* may be performed and the drawings prepared accordingly.

This book explains the nuances *behind some of these steps* of seismic design, though *not the steps themselves*.

1.5 FORCE-BASED DESIGN TO DISPLACEMENT-BASED DESIGN

A change of frame of reference of deformation facilitates converting the moving base problem of earthquake shaking of buildings into a fixed base problem (Figure 1.13). The latter is easy to handle, since design practice is conversant with analysis and design of structures subjected to *forces*, and not subjected to *displacements* or *accelerations*. Therefore, now the acceleration response spectrum allows quick, back-of-the-envelope type calculations by senior engineers to check the ballpark values of force generated in a building during earthquake shaking.

In early days of designing buildings to resist earthquakes, an earthquake-induced *lateral force* was thought to be the root cause of the earthquake problem. Designers observed that buildings performed well, if they were designed for lateral forces; mostly, this lateral force was due to wind effects. Hence, as a first measure of consciously designing for earthquake effects, designers took *10% of the weight of the building* and applied it as a lateral force on the building (distributed along the height). But, the 10% force was too penalising for taller buildings. Around that time, understanding grew on the ground motions, and it was learnt that different buildings respond differently to the same ground shaking. Thus, the design lateral force was now taken as *a function of the fundamental natural period of the building*. This was not sufficient either. Many buildings showed brittle performance, *i.e.*, collapsed suddenly in low seismic regions. This was the beginning of understanding the *importance of introducing ductility* in buildings. But, the method of introducing ductility was prescriptive; it was based on limited laboratory tests performed on structural elements and sub-assemblages.

The above also was found insufficient, when buildings did not collapse, but were rendered not-usable after many strong earthquakes. *Performance of buildings* during and after the earthquake came into focus. And, this was the beginning of a new direction of designing buildings to resist earthquake effects. Fresh thinking began towards *displacement-based design* of buildings. Then, it was clear that *imposed lateral displacement* was the root cause of the earthquake problem and not any *lateral force*. Thus, the present effort in the research community is to arrive at a displacement based design with capability to quantitatively assess the ultimate deformation capacity of buildings at the design stage itself.

In the following chapters, *earthquake DEMAND on the building* and *earthquake CAPACITY of the building* are discussed. While doing so, the associated basic concepts are elaborated and demonstrated with appropriate numerical work.

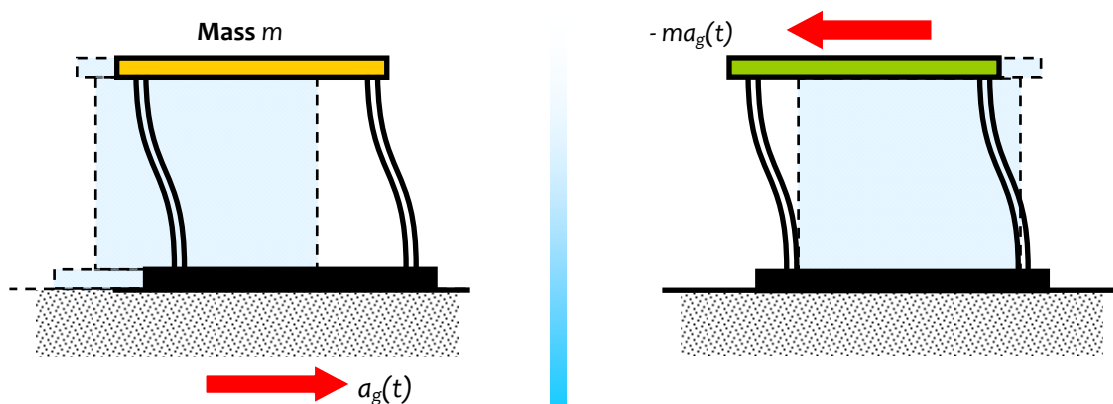


Figure 1.13: Acceleration time history at the base of a building: Converted to a force time history at the mass of the building with the base fixed

...

Chapter 2

Earthquake Demand on Buildings

2.1 SEISMIC DESIGN FORCE

Earthquake shaking is random and time variant. But, most design codes represent the earthquake-induced inertia forces as the net effect of such random shaking in the form of design *equivalent static* lateral force. This force is called as the *Seismic Design Base Shear* V_B and remains the primary quantity involved in *force-based* earthquake-resistant design of buildings. This force depends on the seismic hazard at the site of the building represented by the *Seismic Zone Factor* Z . Also, in keeping with the philosophy of increasing design forces to increase the elastic range of the building and thereby reduce the damage in it, codes tend to adopt the *Importance Factor* I for effecting such decisions (Figure 1.12). Further, the net shaking of a building is a combined effect of the energy carried by the earthquake at different frequencies and the natural periods of the building. Codes reflect this by the introduction of a *Structural Flexibility Factor* S_a/g . Finally, as discussed in section 1.2 of Chapter 1, to make normal buildings economical, design codes allow some damage for reducing cost of construction. This philosophy is introduced with the help of *Response Reduction Factor* R , which is larger for ductile buildings and smaller for brittle ones. Each of these factors is discussed in this and subsequent chapters. In view of the *uncertainties* involved in parameters, like Z and S_a/g , the upper limit of the imposed deformation demand on the building is not known as a *deterministic upper bound value*. Thus, design of earthquake effects is not termed as *earthquake-proof design*. Instead, the earthquake demand is estimated only based on concepts of probability of exceedence, and the design of earthquake effects is termed as *earthquake-resistant design* against the probable value of the demand.

As per the Indian Seismic Code IS:1893 (Part 1) - 2007, *Design Base Shear* V_B is given by:

$$V_B = A_h W = \frac{ZI}{2R} \left(\frac{S_a}{g} \right) W, \quad (2.1)$$

where Z is the *Seismic Zone Factor* (Table 2.1), I the *Importance Factor* (Table 2.2), R the *Response Reduction Factor* (Table 2.3), and S_a/g the *Design Acceleration Spectrum Value* (Figure 2.2) given by:

$$\frac{S_a}{g} = \begin{cases} \begin{cases} 2.5 & 0.00 < T < 0.40 \\ \frac{1.00}{T} & 0.40 < T < 4.00 \end{cases} & \text{for Soil Type I : rocky or hard soil sites} \\ \begin{cases} 2.5 & 0.00 < T < 0.55 \\ \frac{1.36}{T} & 0.55 < T < 4.00 \end{cases} & \text{for Soil Type II : medium soil sites} \\ \begin{cases} 2.5 & 0.00 < T < 0.67 \\ \frac{1.67}{T} & 0.67 < T < 4.00 \end{cases} & \text{for Soil Type III : soft soil sites} \end{cases}, \quad (2.2)$$

in which T is the fundamental translational natural period of the building in the considered direction of shaking.

Table 2.1: Seismic Zone Factor Z as per IS:1893 (Part 1) - 2007 of the site where the building to be designed is located

<i>Seismic Zone</i>	V	IV	III	II
Z	0.36	0.24	0.16	0.10
<i>Note:</i> The zone in which a building is located can be identified from the <i>Seismic Zone Map of India</i> given in IS:1893-2007, sketched in Figure 2.1.				

Table 2.2: Importance Factor Z of buildings as per IS:1893 (Part 1) - 2007

<i>Building</i>	<i>Importance Factor I</i>
Normal Buildings	1.0
Important Buildings (e.g., Critical buildings required to be functional after an earthquake, Lifeline buildings associated with utilities, like water, power & transportation)	1.5

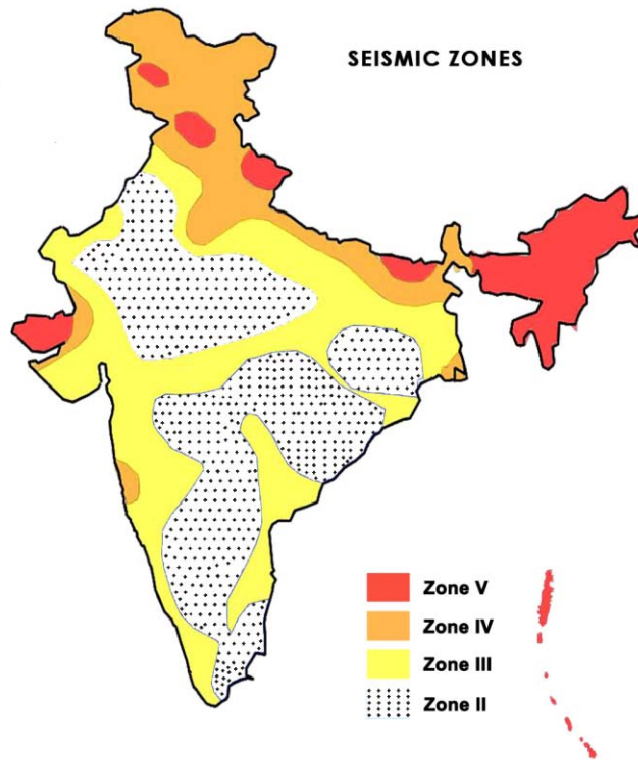


Figure 2.1: Sketch of Seismic Zone Map of India: sketch based on the seismic zone of India map given in IS:1893 (Part 1) - 2007

Table 2.3: Response Reduction Factor R of buildings as per IS:1893 (Part 1) - 2007

<i>Lateral Load Resisting System</i>	<i>R</i>
<i>Building Frame Systems</i>	
Ordinary RC moment resisting frame (OMRF)	3.0
Special RC moment-resisting frame (SMRF)	5.0
Steel frame with	
(a) Concentric braces	4.0
(b) Eccentric braces	5.0
Steel moment resisting frame designed as per SP 6 (6)	5.0
<i>Buildings with Shear Walls</i>	
Ordinary reinforced concrete shear walls	3.0
Ductile shear walls	4.0
<i>Buildings with Dual Systems</i>	
Ordinary shear wall with OMRF	3.0
Ordinary shear wall with SMRF	4.0
Ductile shear wall with OMRF	4.5
Ductile shear wall with SMRF	5.0

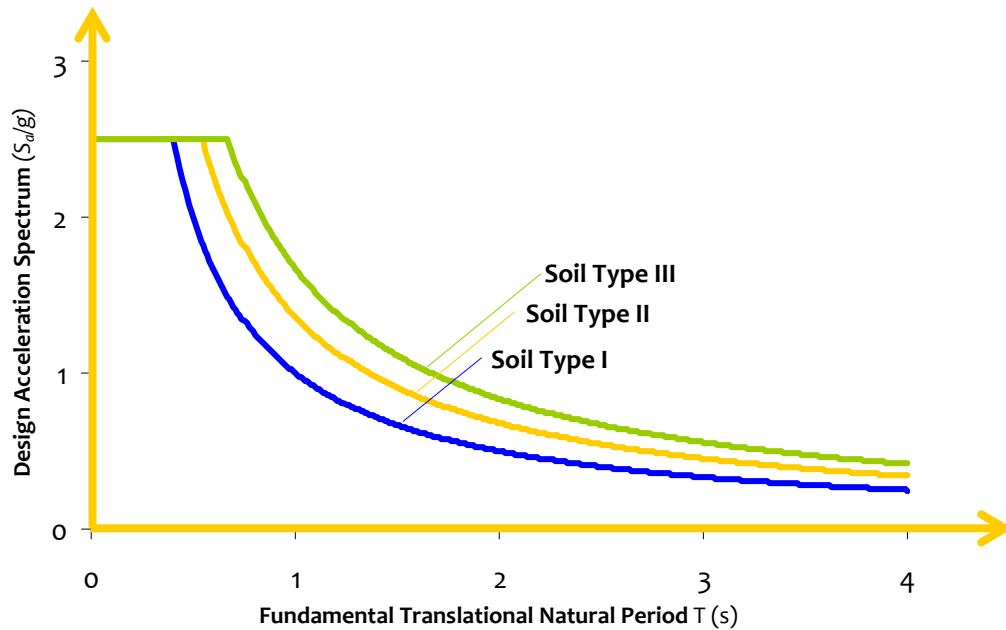


Figure 2.2: *Design Acceleration Spectrum:* This is based on fundamental translational natural period T of the building; this is defined in the following

In Eq.(2.1), W is the *seismic weight* of the building. For the purpose of estimating the seismic weight of the building, full dead load and part live load are to be included. The proportion of live load to be considered is given by IS:1893 (Part 1) as per Table 2.4; live load need not be considered on the roofs of buildings in the calculation of design earthquake force.

While there is lesser control on design acceleration spectrum value A_{ln} , designers can consciously reduce seismic weight W though the mass of the building. Choosing light materials and efficiently using the materials together help reducing the source of design earthquake force on the building. Also, the distribution of this mass in plan and elevation of the building renders earthquake-induced inertia forces to be uniformly distributed throughout the building, instead of being localized at a few parts of the building.

Table 2.4: Proportion of Live Load to be considered in the estimate of Seismic Weight of buildings as per IS:1893-2004

<i>Imposed Uniformity Distributed Floor Loads (kN/m²)</i>	<i>Percentage of Imposed Load</i>
Up to and including 3.0	25
Above 3.0	50

2.2 DYNAMIC CHARACTERISTICS OF BUILDINGS

Buildings oscillate during earthquake shaking. The oscillation causes inertia force to be induced in the building. The intensity and duration of oscillation, and the amount of inertia force induced in a building depend on features of buildings, called their *dynamic characteristics*, in addition to the characteristics of the earthquake shaking itself. The important dynamic characteristics of buildings are *modes of oscillation* and *damping*. A mode of oscillation of a building is defined by associated *Natural Period* and *Deformed Shape* in which it oscillates.

2.2.1 Natural Period

Natural Period T_n of a building is the time taken by it to undergo one complete cycle of oscillation. It is an inherent property of a building controlled by its mass m and stiffness k . These three quantities are related by

$$T_n = 2\pi\sqrt{\frac{m}{k}}; \quad (2.3)$$

its units are seconds (s). Thus, buildings that are heavy (with larger mass m) and flexible (with smaller stiffness k) have larger natural period than light and stiff buildings. Buildings oscillate by translating along X, Y or Z directions, or by rotating about X, Y or Z axes, or by a combination of the above (Figure 2.3). When a building oscillates, there is an associated shape of oscillation.

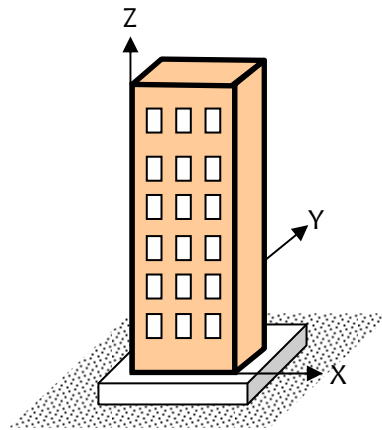


Figure 2.3: Cartesian coordinates of a regular building: Buildings oscillate by translating along X, Y or Z directions or/and by rotating about X, Y or Z axes

The reciprocal ($1/T_n$) of natural period of a building is called the *Natural Frequency* f_n ; its unit is Hertz (Hz). The building offers least resistance when shaken at its natural frequency (or natural period). Hence, it undergoes larger oscillation when shaken at its natural frequency than at other frequencies (Figure 2.4). Usually, natural periods (T_n) of 1 to 20 storey normal reinforced concrete and steel buildings are in the range of 0.05 - 2.00s. In building design practice, engineers usually work with T_n and not f_n . Resonance will occur in a building, only if frequency at which ground shakes is steady at or near any of the natural frequencies of building and applied over an extended period of time. But, earthquake ground motion has departures from these two conditions. First, the ground motion contains a basket of frequencies that are continually and randomly changing at each instant of time. There is no guarantee that the ground shaking contains the same frequency (and that too close to f_n of the building) throughout or even for a sustained duration. Second, the small duration for which the ground shaking occurs at frequencies close to f_n of the building, is insufficient to build resonant conditions in most cases of the usual ground motions. Hence, usually, increased response occurs, but not resonance, when earthquake shaking carries energy in frequencies close to f_n of the building that is randomly fed to the building during earthquake shaking. One of few cases of *resonance* during earthquake shaking was noticed during the 1985 Mexico City earthquake, where buildings having natural periods in a small range alone collapsed, while those with natural periods outside the range performed normally. This is attributed to the almost uniform thickness of the underlying soil portion of the city built in the valley (*i.e.*, in a bowl between mountains), which acted like a filter for all other frequencies in the earthquake shaking.

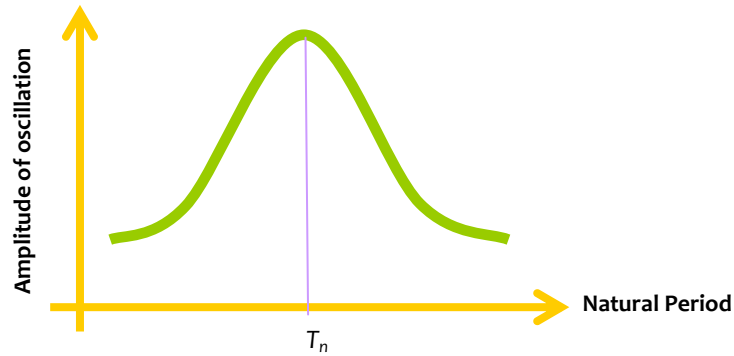


Figure 2.4: *Natural frequency of a building:* Amplitude of oscillation (or any response) of building increases when the building is shaken at or near its natural frequency

(a) Fundamental Natural Period of Building

Every building has a number of natural frequencies, at which it offers minimum resistance to shaking induced by *external effects* (like earthquakes and wind) and *internal effects* (like motors fixed on it). Each of these natural frequencies and the associated deformation shape of a building constitute a *Natural Mode of Oscillation*. The mode of oscillation with the smallest natural frequency (and largest natural period) is called the *Fundamental Mode*; the associated natural period T_1 is called the *Fundamental Natural Period* (Figure 2.5) and the associated natural frequency f_1 the *Fundamental Natural Frequency*. Further, regular buildings held at their base from translation in the three directions, have

- (1) three fundamental translational natural periods, T_{x1} , T_{y1} and T_{z1} , associated with its horizontal translational oscillation along X and Y directions, and vertical translational oscillation along Z direction, respectively, and
- (2) one fundamental rotational natural period $T_{\theta 1}$ associated with its rotation about an axis parallel to Z axis.

In reality, the number of natural modes of a building is infinity. But, for engineering purposes, the number of modes is finite. For instance, when the finite element model (FEM) of the building is prepared, the buildings is discretised into members meeting at nodes. Each node has a maximum of 6 *degrees of freedom* (freedom of movement available to the node along the Cartesian coordinate system, namely three *translations* and three *rotations*). Hence, for a building with many nodes, the maximum degrees of freedom can be counted to be finite, say N . Here, the building is said to have N *natural modes of oscillation*. In normal buildings, N can be large. But, often, only a few modes are necessary for engineering calculations to assess the response of buildings.

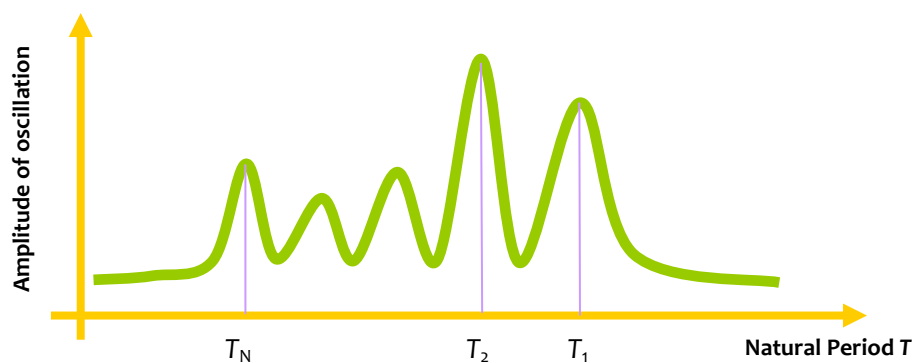


Figure 2.5: *Multiple natural periods:* Amplitude of oscillation of a building or any of its responses (e.g., bending moments in columns) is amplified when shaken at the natural frequencies

(b) Factors influencing Natural Period

Numerical results are used to explain the concept of natural period and the factors that influence it. Reinforced concrete moment resistant frame buildings are used to illustrate the concept; some properties of these buildings are listed in Table 2.5. One of these buildings, namely a five-storey building, is chosen as the basis, and is hereinafter called the *Benchmark Building*. It is a bare frame with a plinth beam (and no slab) at ground floor level. The details of this benchmark building are (Figure 2.6):

Structural Element Sizes

Beams	: 300 × 400 mm
Columns	: 400 × 400 mm
Slab	: 150 mm thick

Material Properties

Grade of Concrete	: M30
Grade of Steel Reinforcement Bars	: Fe 415

Loading

Dead Load on beams from infill wall	: 10 kN/m
(Thickness of infill wall	: 0.25 m
Clear height of infill wall	: 2.45 m
Unit Weight of infill wall	: 20 kN/m ³
Openings in walls	: 20%
Live load on floor	: 3 kN/m ²

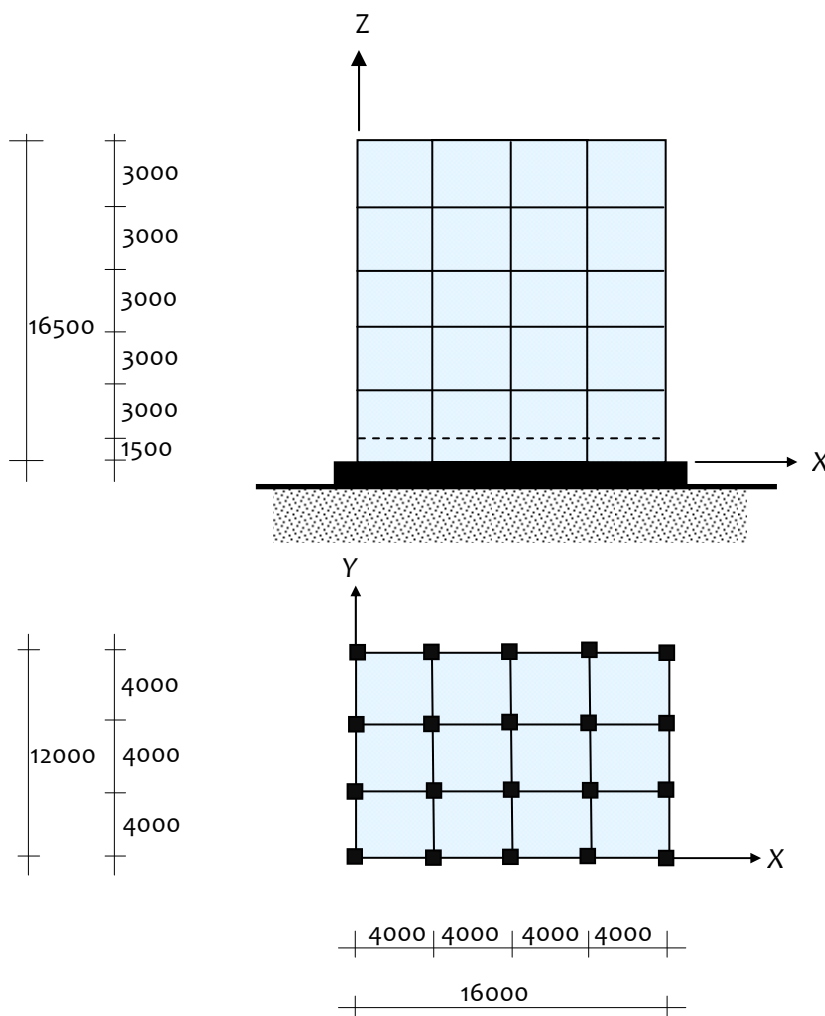


Figure 2.6: Five-storey Benchmark Building: Elevation and plan of benchmark building showing the structural moment frame grid (All dimensions are in mm)

Table 2.5: Buildings considered to illustrate concept of natural period: Details of 10 buildings considered

Building	Description	Number of Storeys	Number of Bays		Column Dimension (mm × mm)
			X-direction	Y-direction	
A	2 storey building	2	4	3	400 × 400
B	Benchmark 5-storey building	5	4	3	400 × 400
C	Benchmark building with rectangular columns oriented along X direction	5	4	3	550 × 300
D	Benchmark building with rectangular columns oriented along Y direction	5	4	3	300 × 550
E	10-storey building with varying column size along building height	10	4	3	Upper 5 storeys: 400 × 400
					Bottom 5 storeys: 600 × 600
F	10-storey building	10	4	3	600 × 600
G	25-storey building with varying column size along building height	25	4	3	Upper 5 storeys: 400 × 400
					Middle 10 storeys: 600 × 600
					Bottom 10 storeys: 800 × 800
H	25-storey building	25	4	3	800 × 800
J	25-storey building with imposed mass 10% larger than building H	25	4	3	800 × 800
K	25-storey building with imposed mass 20% larger than building H	25	4	3	800 × 800

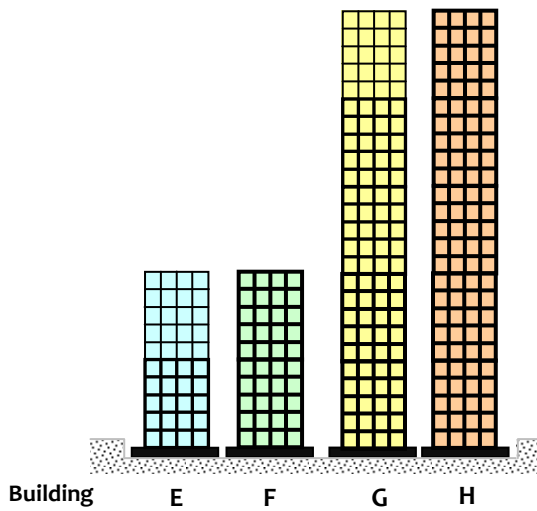
Note

1. Bay length in each plan direction is 4m (center to center).
2. All columns at each storey are of the same size.
3. All beams in all buildings are of the same size (300mm × 400mm)

(1) Effect of Stiffness

Increasing the column size increases both stiffness and mass of buildings. But, when the percentage increase in stiffness as a result of increase in column size is larger than the percentage increase in mass, the natural period reduces. Hence, the usual discussion that increase in column size reduces the natural period of buildings (motivated by Eq.(2.3)), does not consider the simultaneous increase in mass; in that context, buildings are said to have shorter natural periods with increase in column size.

Buildings E and F are two 10-storey buildings with different column sizes along the elevation; building F has column size of 600×600 throughout the height, while building E has smaller column size (of 400×400) in the upper 5 storeys (Figure 2.7). Thus, building F (with 600×600 column throughout) is relatively stiffer than Building E and the fundamental period of the stiffer building F (1.35 s) is only marginally smaller than that of the building E (1.36 s). The deformed shape of the building indicates that most of the deformation is occurring only in the lower storeys (because of shear-type of lateral deformation in the building), where the columns size is same. Hence, the influence on the overall natural period is not perceptible. But, if column sizes are changed in the lower storeys also, the natural period will differ significantly. Between buildings G and H, the latter is much stiffer. But, while increasing stiffness, the mass is also increased. In arriving at the natural period, the mass and stiffness compete as in Eq.(2.3) to determine whether the natural period will increase or decrease, when both are changed.



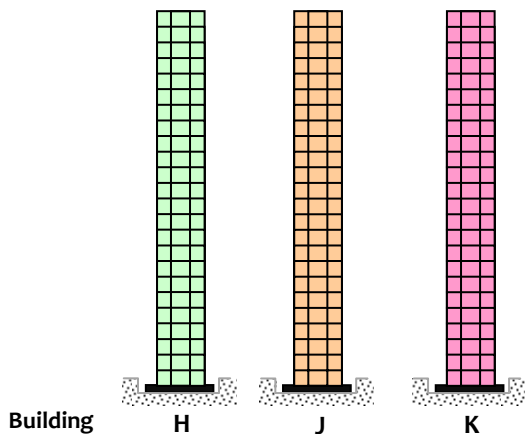
Building E	Building F
$T_{X1} = 1.32 \text{ s}$	$T_{X1} = 1.31 \text{ s}$
$T_{Y1} = 1.36 \text{ s}$	$T_{Y1} = 1.35 \text{ s}$
Building G	Building H
$T_{X1} = 2.89 \text{ s}$	$T_{X1} = 2.98 \text{ s}$
$T_{Y1} = 3.04 \text{ s}$	$T_{Y1} = 3.14 \text{ s}$

Figure 2.7: Effect of stiffness: Stiffer buildings have smaller natural period

(2) Effect of Mass

Mass of a building that is *effective* in lateral oscillation during earthquake shaking is called the *seismic mass of the building*. It is the sum of its seismic masses at different floor levels. Seismic mass at each floor level is equal to full dead load plus appropriate fraction of live load. The fraction of live load depends on the intensity of the live load and how it is connected to the floor slab. Seismic design codes of each country/region provide fractions of live loads to be considered for design of buildings to be built in that country/region.

An increase in mass of a building increases its natural period (Eq.(2.3)). Buildings H, J and K are all 25-storey buildings with same plan size, elevation and column sizes, but with different floor mass (Figure 2.8). Imposed floor mass in building H is 2,150kN, while that in buildings J and K are 10% and 20% larger, respectively. Fundamental translational natural periods of heavier buildings K (3.43 s) and J (3.29 s) are larger than that of building H (3.14 s).



Building H	Building J	Building K
Mass m	Mass 1.1m	Mass 1.2m
$T_{X1} = 2.98 \text{ s}$	$T_{X1} = 3.12 \text{ s}$	$T_{X1} = 3.25 \text{ s}$
$T_{Y1} = 3.14 \text{ s}$	$T_{Y1} = 3.29 \text{ s}$	$T_{Y1} = 3.43 \text{ s}$

Figure 2.8: Effect of mass: Heavier buildings have larger natural period

(3) Effect of Building Height

As the height of building increases, its mass increases but its overall stiffness decreases. Hence, the natural period of a building increases with increase in height. Buildings A, B, F and H have same plan size, but are of different heights. Taller buildings have larger fundamental natural period than shorter ones (Figure 2.9); the fundamental translational natural periods of 25-storey building H, 10-storey building F, 5-storey building B and 2-storey building A are 3.14s, 1.35s, 0.89s and 0.45s, respectively.

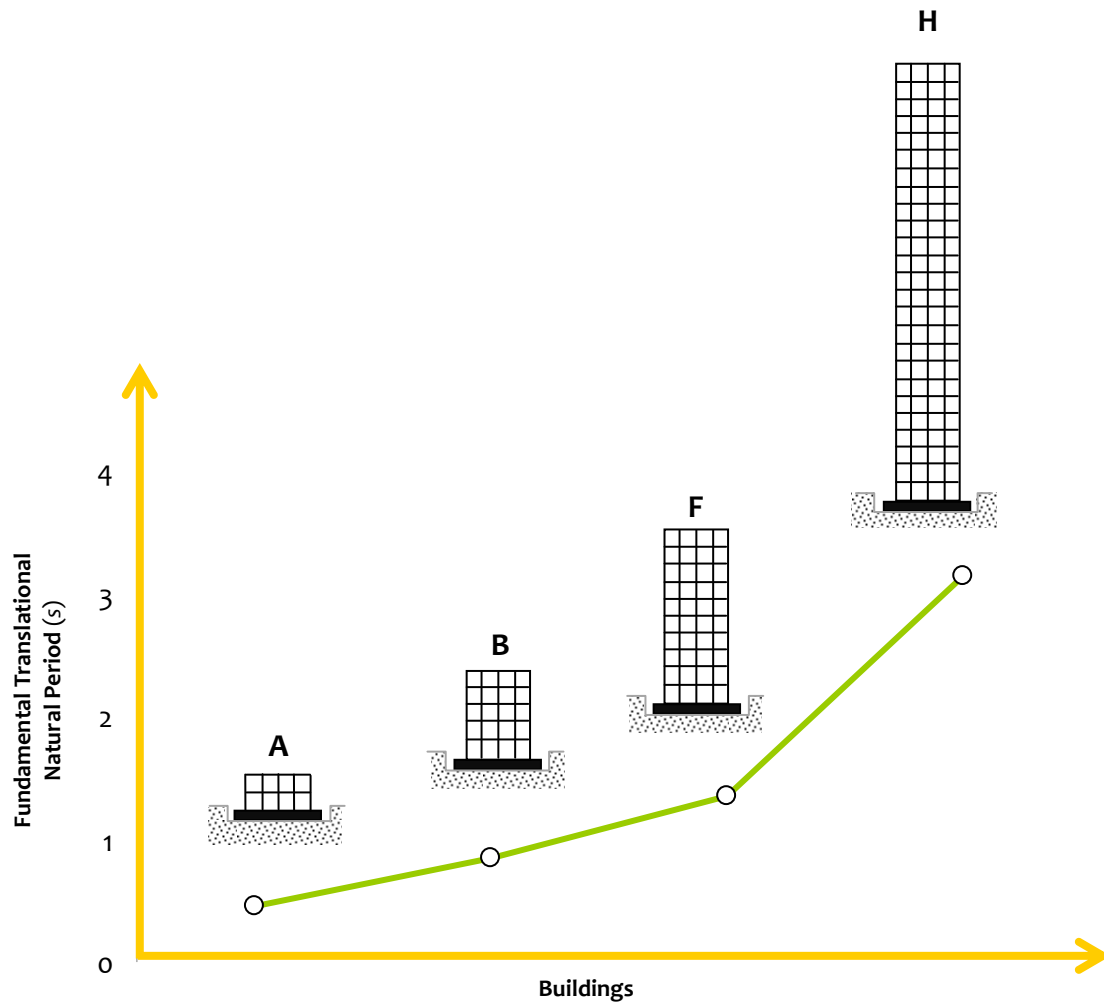


Figure 2.9: Effect of building height: Taller buildings have larger natural period

(4) Effect of Column Orientation

Orientation of rectangular columns influences lateral stiffness of buildings along two horizontal directions. Hence, changing the orientation of columns changes the translational natural period of buildings. Buildings C and D are two 5-storey buildings with same column area, but with different orientation of rectangular columns. Longer side of 550mm×300mm columns is oriented along X-direction in building C, and along Y-direction in building D. Lateral stiffness of columns along longer direction is more. Hence, natural period of buildings along the longer direction of column cross-section is smaller than that along the shorter direction (Figure 2.10).

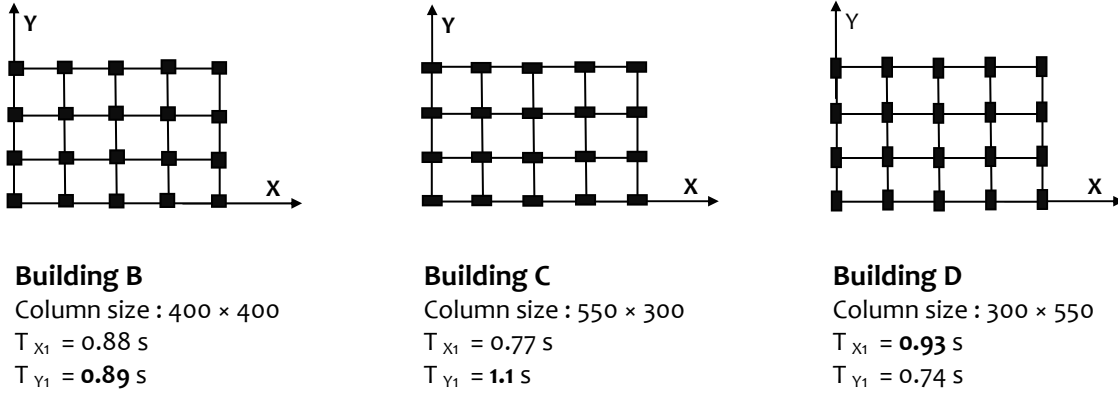


Figure 2.10: Effect of column orientation: Buildings with larger column dimension oriented in the direction reduces the translational natural period of oscillation in that direction

(5) Effect of Unreinforced Masonry Infill Walls in RC Frames

In many countries, the space between the beams and columns of building are filled with unreinforced masonry (URM) infills. These infills participate in the lateral response of buildings and as a consequence alter the lateral stiffness of buildings. Hence, natural periods (and modes of oscillation) of the building are affected in the presence of URM.

In conventional design practice, the masses of the infill walls are considered, but their lateral stiffness are not. Modeling the infill wall along with the frame elements (*i.e.*, beams and columns) is necessary to incorporate additional lateral stiffness offered by URM infill walls. Consider buildings A, B, F and H as discussed above. In addition to the RC beams and columns, URM infills also are modeled. These infills are replaced by equivalent diagonal struts, with thickness equal to thickness of URM infill wall (of 250mm, say) and width equal to 1000mm, a fraction of the diagonal length, and material properties as suggested in literature [*e.g.*, IITK-GSDMA, 2007]. As a result, lateral stiffness of buildings increases when URM infill walls are included in the analysis models. Thus, natural period of a building is *lower*, when *stiffness of URM infill is considered*, than when it is *not considered* (Figure 2.11). The extent of stiffness enhancement and change in natural period due to URM infills depends on the extent and spatial distribution of URM infills. Change in natural period is higher in shorter buildings (*e.g.*, in Buildings A and B when modeled as bare frame and with URM infill walls) as compared to that in tall buildings (*e.g.*, in Buildings F and H when modeled as bare frame and with URM infill walls). This implies that seismic behaviour of shorter buildings is affected significantly as compared to that of taller buildings, when stiffness enhancement due to URM is considered.

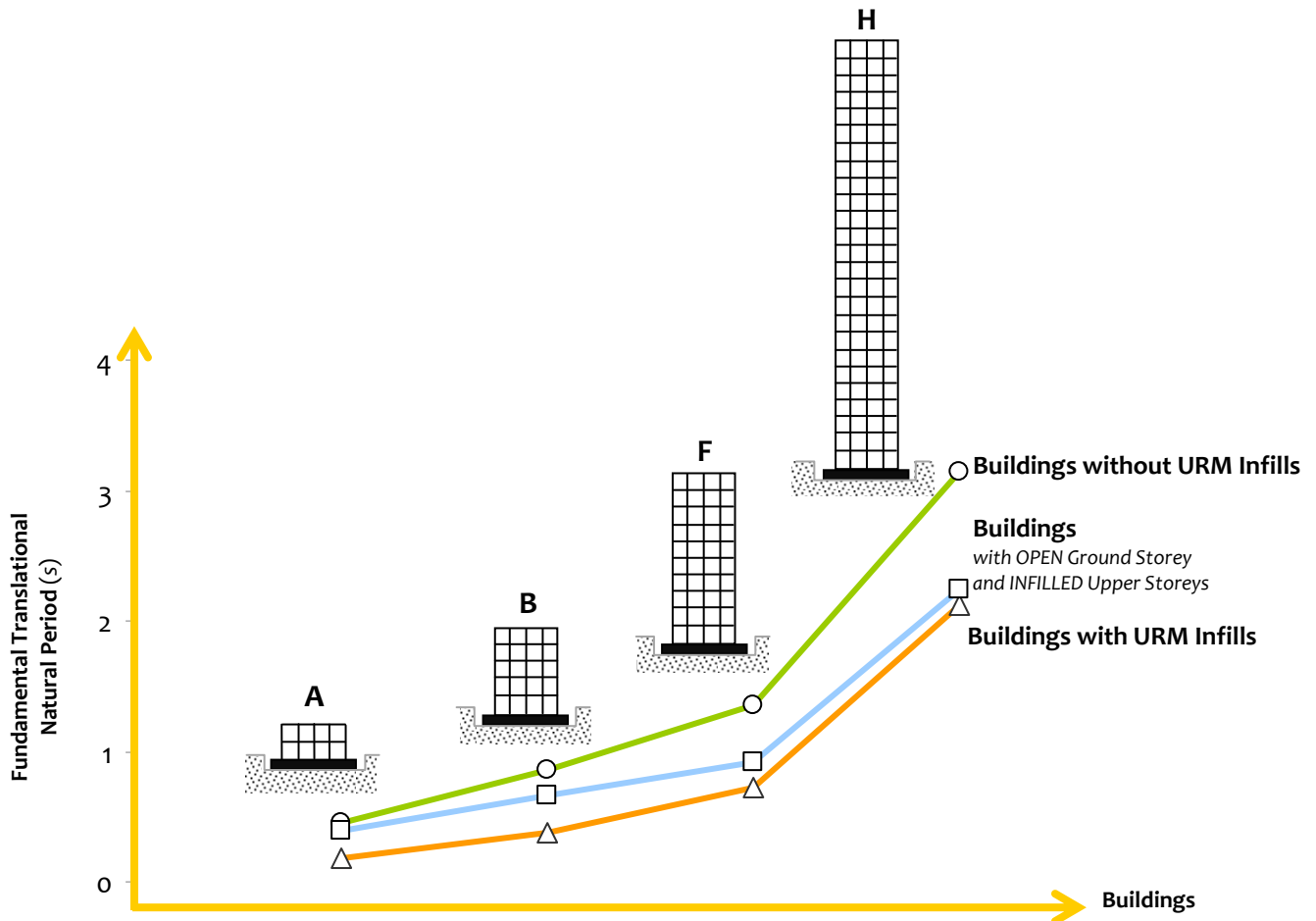


Figure 2.11: Effect of Unreinforced Masonry Infills: Natural Period of building is lower when the stiffness contribution of URM infill is considered

(6) Effect of Cracked Sections on Analysis of RC Frames

Proper estimation of flexural stiffness of each individual members is essential for capturing (a) dynamic characteristics of a building, and (b) force and deformation demands imposed on the building and its members. Reinforced concrete poses a special challenge of capturing the most suitable cross-section property, especially when sections undergo extensive cracking during earthquake shaking. The choice is between *Gross* and *Cracked Cross-Sectional Properties* associated with *axial, flexural, shear* and *torsional* actions. *Gross cross-sectional properties* are computed using gross sectional area *without considering the stiffness enhancement due to the presence of longitudinal reinforcement*; here, the extent of cracking of the member is assumed to be minimal. Often, *gross properties* are commonly used for estimating force and deformation demands on members subjected to gravity loading based on linear analysis. But, in members where extensive cracking is expected during earthquake shaking, estimation of force and deformation demands based on *gross properties* may not represent the true behaviour. *Effective properties* are necessary to overcome this shortcoming and represent reduced stiffness of members in their damaged state. Effective properties are arrived at based on extensive analytical and experimental studies on buildings/members subjected to seismic loading; they are expressed as a fraction of gross stiffness (Table 2.6). For instance, the ratio of effective moment of inertia to gross moment of inertia of columns is higher than that of beams, because damage expected in columns is lower owing to presence of compressive axial load in them. The actual ratio depends, for example, on the level of compressive axial load, among many other factors; thus, literature on the subject has different suggestions. For instance, one document [Paulay and Priestley, 1992] suggests that $I_{b,eff} = 0.35I_{b,gross}$ for beams and $I_{c,eff} = 0.70I_{c,gross}$ for columns. Using these values, the fundamental natural periods of buildings A, B, F and H are estimated; results indicate that natural periods estimated using gross stiffness are lower than those estimated using effective stiffness (Figure 2.12).

Table 2.6: Effective Stiffness of Member [Paulay and Priestley, 1992]

Type of Member	Range	Recommended Value
Rectangular Beams	$0.30I_g - 0.50I_g$	$0.40I_g$
T and L Beam	$0.25I_g - 0.45I_g$	$0.35I_g$
Columns ($P > 0.5f_cA_g$)	$0.70I_g - 0.90I_g$	$0.80I_g$
Columns ($P > 0.2f_cA_g$)	$0.50I_g - 0.70I_g$	$0.60I_g$
Columns ($P > -0.05f_cA_g$)	$0.30I_g - 0.50I_g$	$0.40I_g$

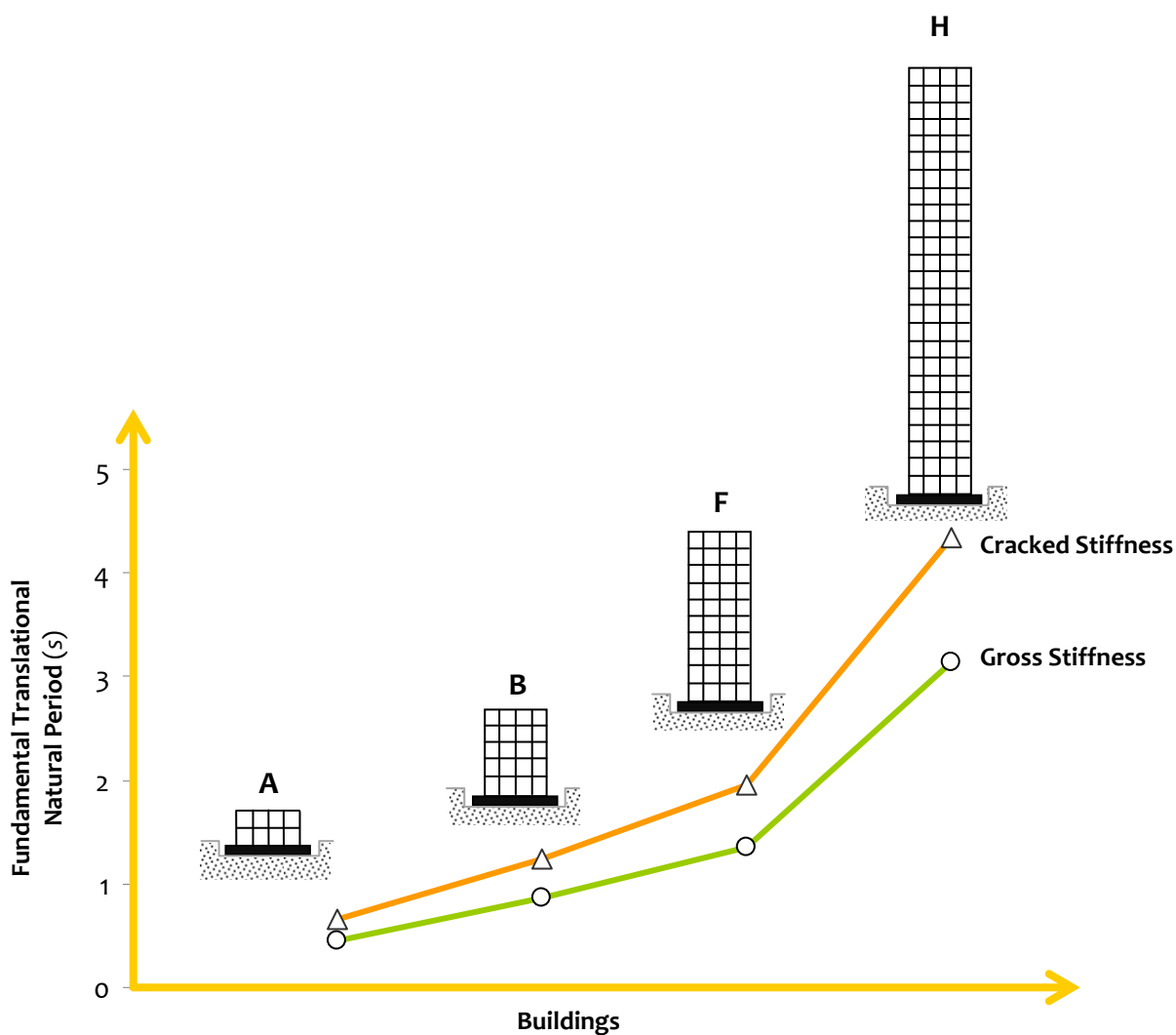


Figure 2.12: Effect of Analysis and Design Consideration: Natural Period of building is estimated using Gross Stiffness is lower than natural period of building estimated using Effective Stiffness.

(c) Design Practice

Fundamental natural period is an important parameter in earthquake-resistant design. Design horizontal acceleration A_h or design horizontal base shear coefficient V_B/W of a building is a function of its translational natural periods in the considered direction of design lateral force. Sometimes, only the fundamental period is used in obtaining the design base shear. Design codes give smoothed curves to estimate design base shear coefficient as a function of estimated fundamental translational natural period of a building (Figure 2.13). The curve indicates that the design earthquake shaking contains significant energy associated with natural periods in the range 0.04-2.00s (or with natural frequencies in the range of 0.5-25.0Hz).

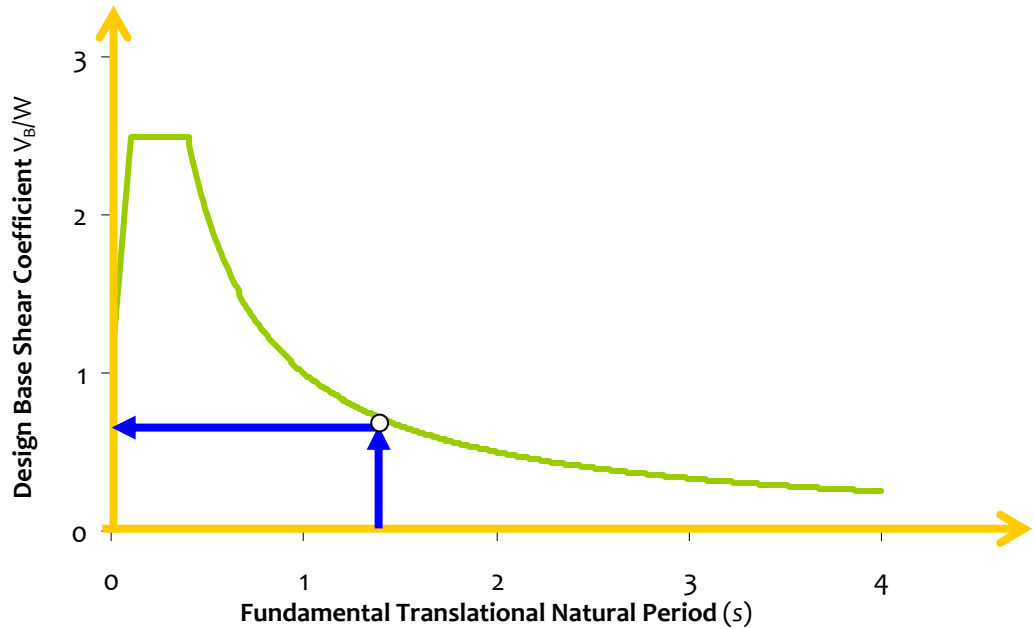


Figure 2.13: *Effect of Natural Period on design horizontal seismic force coefficient:* In general, buildings with smaller translational natural period attract higher design seismic force coefficient

In summary, natural periods of buildings depend on the distribution of mass and stiffness along the building (in all directions). Some major trends related to natural periods of buildings of regular geometries are (Figure 2.14):

1. Natural periods of buildings reduce with increase in stiffness.
2. Natural periods of buildings increase with increase in mass.
3. Taller buildings have larger fundamental translational natural periods.
4. Buildings tend to oscillate in the directions in which they are most flexible and have larger translational natural periods.
5. Natural periods of buildings depend on amount and extent of spatial distribution of unreinforced masonry infill walls.

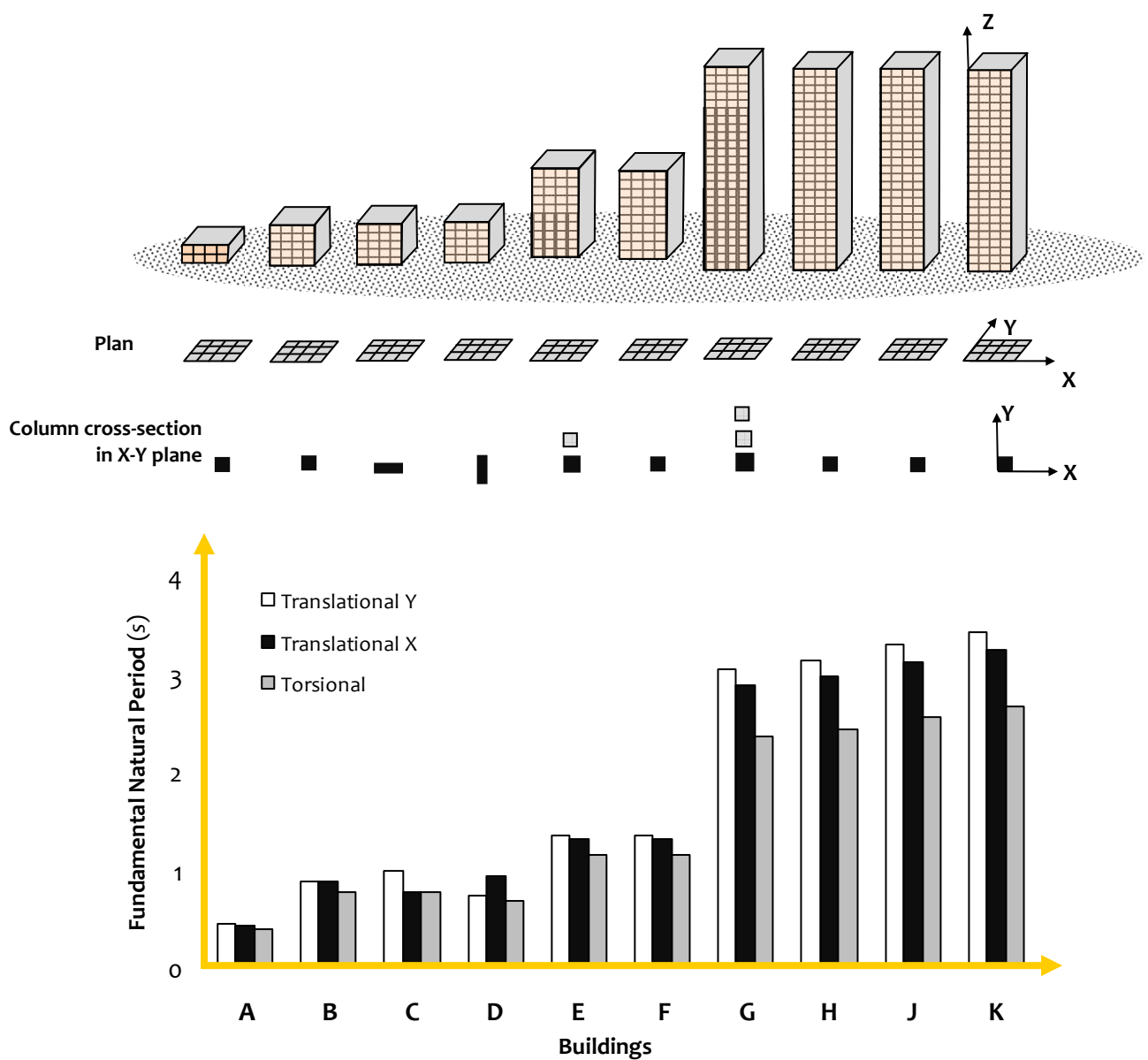


Figure 2.14: Summary of natural periods of buildings considered: Natural periods are influenced by mass and stiffness parameters of buildings

2.2.2 Mode Shape

Mode shape of oscillation associated with a natural period of a building is the deformed shape of the building when shaken at the natural period. Hence, a building has as many mode shapes as the number of natural periods. For a building, there are infinite numbers of natural period. But, in the mathematical modeling of building, usually the building is *discretised* into a number of *elements*. The junctions of these elements are called *nodes*. Each node is free to translate in all the three Cartesian directions and rotate about the three Cartesian axes. Hence, if the number of nodes of discretisation is N , then there would be $6N$ modes of oscillation, and associated with these are $6N$ natural periods and mode shapes of oscillation. The deformed shape of the building associated with oscillation at *fundamental* natural period is termed its *first mode shape*. Similarly, the deformed shapes associated with oscillations at *second*, *third*, and other higher natural periods are called *second mode shape*, *third mode shape*, and so on, respectively.

(a) Fundamental Mode Shape of Oscillation

There are three basic modes of oscillation, namely, pure translational along X-direction, pure translational along Y-direction and pure rotation about Z-axis (Figure 2.15). Regular buildings have these pure mode shapes. Irregular buildings (*i.e.*, buildings that have irregular geometry, non-uniform distribution of mass and stiffness in plan and along the height) have mode shapes that are a mixture of these pure mode shapes. Each of these mode shapes is independent, implying, it cannot be obtained by combining any or all of the other mode shapes.

The overall response of a building is the sum of the responses of all of its modes. The contributions of different modes of oscillation vary; usually, contributions of some modes dominate. It is important to endeavor to make buildings regular to the extent possible. But, in regular buildings too, care should be taken to locate and size the structural elements such that *torsional* and *mixed* modes of oscillation do not participate much in the overall oscillatory motion of the building. One way of avoiding torsional modes to be the early modes of oscillation in buildings is increasing the torsional stiffness of building. This is achieved by adding in-plane stiffness in the vertical plane in select bays along the perimeter of the building; this addition of stiffness should be done along both plan directions of the building, such that the building has no stiffness eccentricity. Adding braces or introducing structural walls in select bays are some common ways in which this is done.

Also, there are a number of possibilities in which buildings can oscillate along each direction of oscillation. Consider a building oscillating along the X-axis (Figure 2.16). It offers least resistance to motion while oscillating in its fundamental mode, and increased resistance to oscillation in the higher modes (second, third, and so on). A special situation arises in buildings that are perfectly symmetric in mass and stiffness distribution in both plan and elevation, say square in plan. Some fundamental or early modes of oscillation are along the *diagonal* direction (Figure 2.17) and not along the sides of the building (*i.e.*, along X- or Y-directions). Generally, in such cases, the *torsional* mode is also an early mode of oscillation. In such buildings, columns undergo bending about axes oriented along their diagonal. But rectangular columns have least resistance along their diagonal directions. Hence, their corners of the columns are severely damaged under this type of oscillation of buildings (Figure 2.18). This situation can be avoided by ensuring that the building (1) does not having the same structural configuration about *BOTH* plan axes (X and Y) passing through the center of mass, AND (2) is symmetric about *EACH* of the two plan axes (X and Y) individually passing through the center of mass.

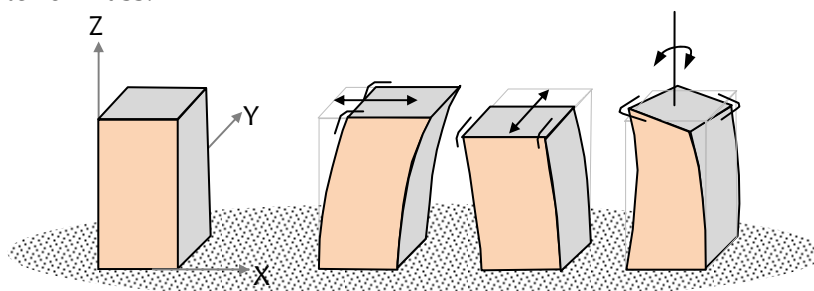


Figure 2.15: Basic modes of oscillation: Two translational and one rotational mode shapes

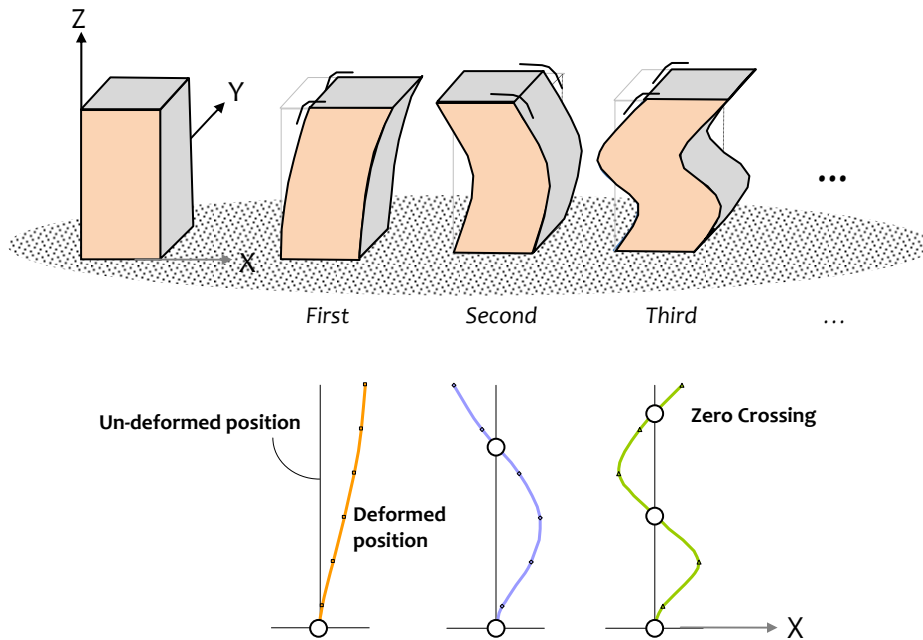


Figure 2.164: Fundamental and two higher translational modes of oscillation along X-direction of a five-storey benchmark building: First modes shape has one zero crossing of the un-deformed position, second two, and third three

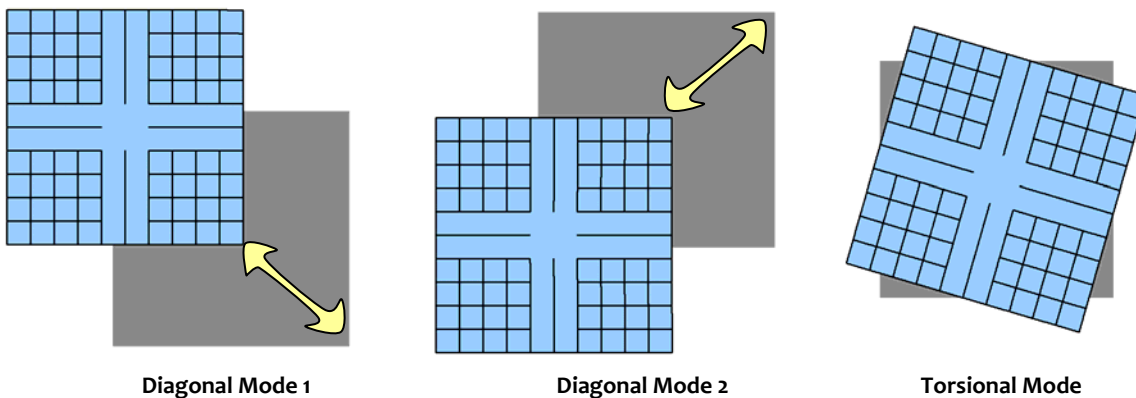


Figure 2.17: Diagonal modes of oscillation: First three modes of oscillation of a building symmetric in both directions in plan; first and second are diagonal translational modes and third rotational

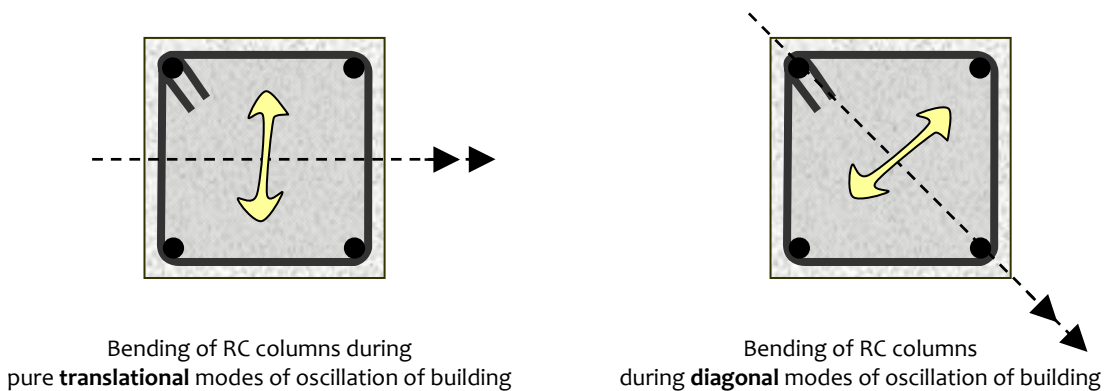
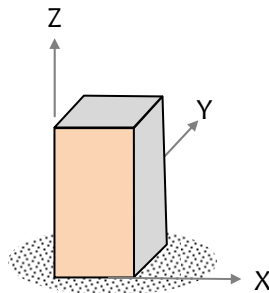
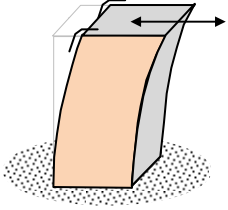
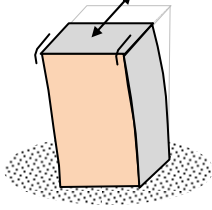
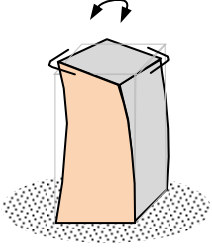


Figure 2.18: Effect of modes of oscillation on column bending: Columns are severely damaged while bending about their diagonal direction

Three-dimensional mode shapes of Benchmark Building
Basics



<p>Translation in X-direction</p> 	<p>Translation in Y-direction</p> 	<p>Rotation about Z-axis</p> 
<p>First Translational Mode in <u>X-direction</u></p>	<p>First Translational Mode in <u>Y-direction</u></p>	<p>First Torsional Mode about <u>Z-axis</u></p>
<p>Second Translational Mode in <u>X-direction</u></p>	<p>Second Translational Mode in <u>Y-direction</u></p>	<p>Second Torsional Mode about <u>Z-axis</u></p>
<p>Third Translational Mode in <u>X-direction</u></p>	<p>Third Translational Mode in <u>Y-direction</u></p>	<p>Third Torsional Mode about <u>Z-axis</u></p>
<p>Click on the 9 items above to see the animation of the mode shapes Best when viewed using Windows Media Player</p>		

(b) Factors influencing Mode Shapes

Mode shapes of buildings depend on overall geometry of building, geometric and material properties of structural members, and connections between the structural members and the ground at the base of the building. Buildings exhibit flexural mode shape, shear mode shape, or a combination of these depending on the above factors.

(1) Effect of Flexural Stiffness of Structural Elements

The overall lateral translational mode shapes depend on *flexural stiffness* of beams relative to that of adjoining columns. The fundamental mode shape of buildings changes from *flexural-type* to *shear-type* as beam flexural stiffness increases relative to that of column (Figure 2.19). On one hand, in pure flexural response (when flexural stiffness of beams is small compared to that of the adjoining columns), column deformation is predominantly in single curvature bending leading to overall flexure-type deformation behaviour of (the cantilever) building (Figure 2.19a). And, on the other hand, in *pure shear-type* deformation behaviour (when flexural stiffness of beams is large compared to that of the adjoining columns), column deformation is predominantly in double curvature bending within in each storey leading to overall shear-type deformation behaviour of building (Figure 2.19b). But, increasing the flexural stiffness of a beam also increases its strength; this is not desirable when strengths of beams exceed that of columns into which they frame in, especially when beam strengths exceed those of the columns adjoining.

Often in low-rise and mid-rise buildings that are designed as per codes, the relative stiffness of frame members lies in between the above two extreme cases. With the usual finite ratio of beam to column flexural stiffness, both beams and columns bend in double curvature and the response is almost of shear type (Figure 2.17c). Thus, often, real buildings are idealized as shear buildings in structural analysis.

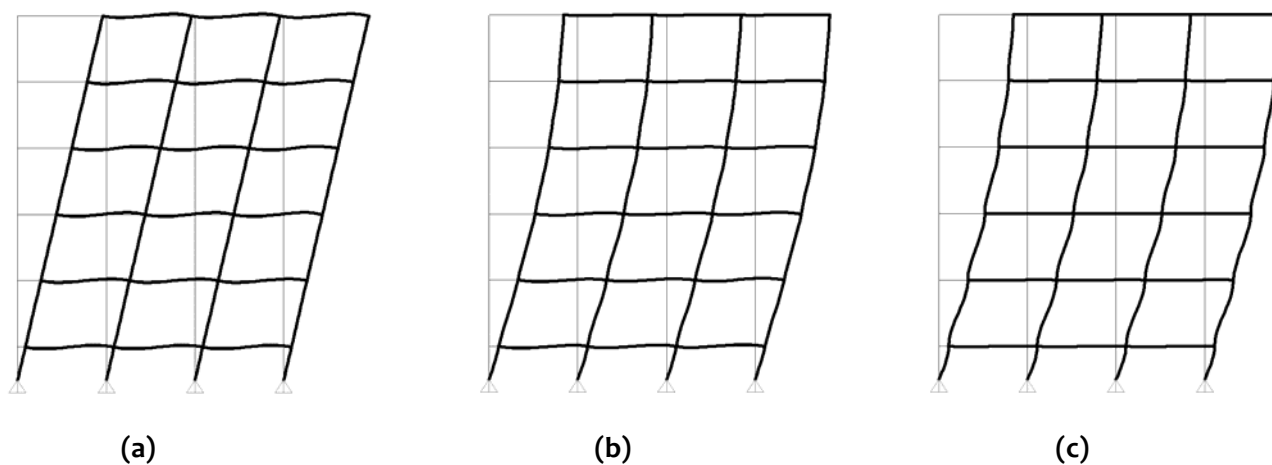
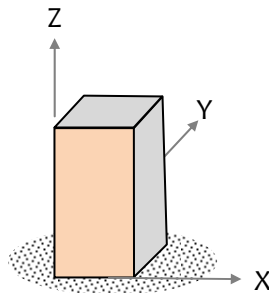


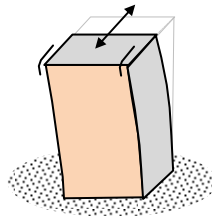
Figure 2.19: Effect of relative flexural stiffness of structural elements: Fundamental translational mode shape changes from flexural-type to shear-type with increase in beam flexural stiffness relative to that of column

Animation Set 202

Three-dimensional mode shapes of Benchmark Building Effect of Flexural Stiffness of Beams



Fundamental Translation in Y-direction



SMALL Flexural Stiffness of Beams

First translational mode in X-direction

NORMAL Flexural Stiffness of Beams

First translational mode in X-direction

LARGE Flexural Stiffness of Beams

First translational mode in X-direction

Click on the 3 items above to see the animation of the mode shapes
Best when viewed using Windows Media Player

(2) Effect of Axial Stiffness of Vertical Members

Mode shapes depend on axial stiffness of vertical members in a building (i.e., of columns or structural walls). Small axial stiffness causes significant axial compressive and tensile deformations in columns in addition to single or double curvature flexural deformations. Additional axial deformation changes the fundamental mode shape from shear type to flexural type, particularly in tall buildings. This can happen primarily in two circumstances; firstly, when the axial load level is large, and secondly, when the axial cross-sectional area is small of vertical members. The fundamental mode shapes of the 25-storey building H discussed earlier are of flexure- and shear-types for two conditions of very small and large axial stiffness of columns, respectively (Figure 2.20). Pure flexural response is not desirable because of large lateral sway, particularly at higher floors. Hence, designers ensure that the axial areas are large of building columns and structural walls.

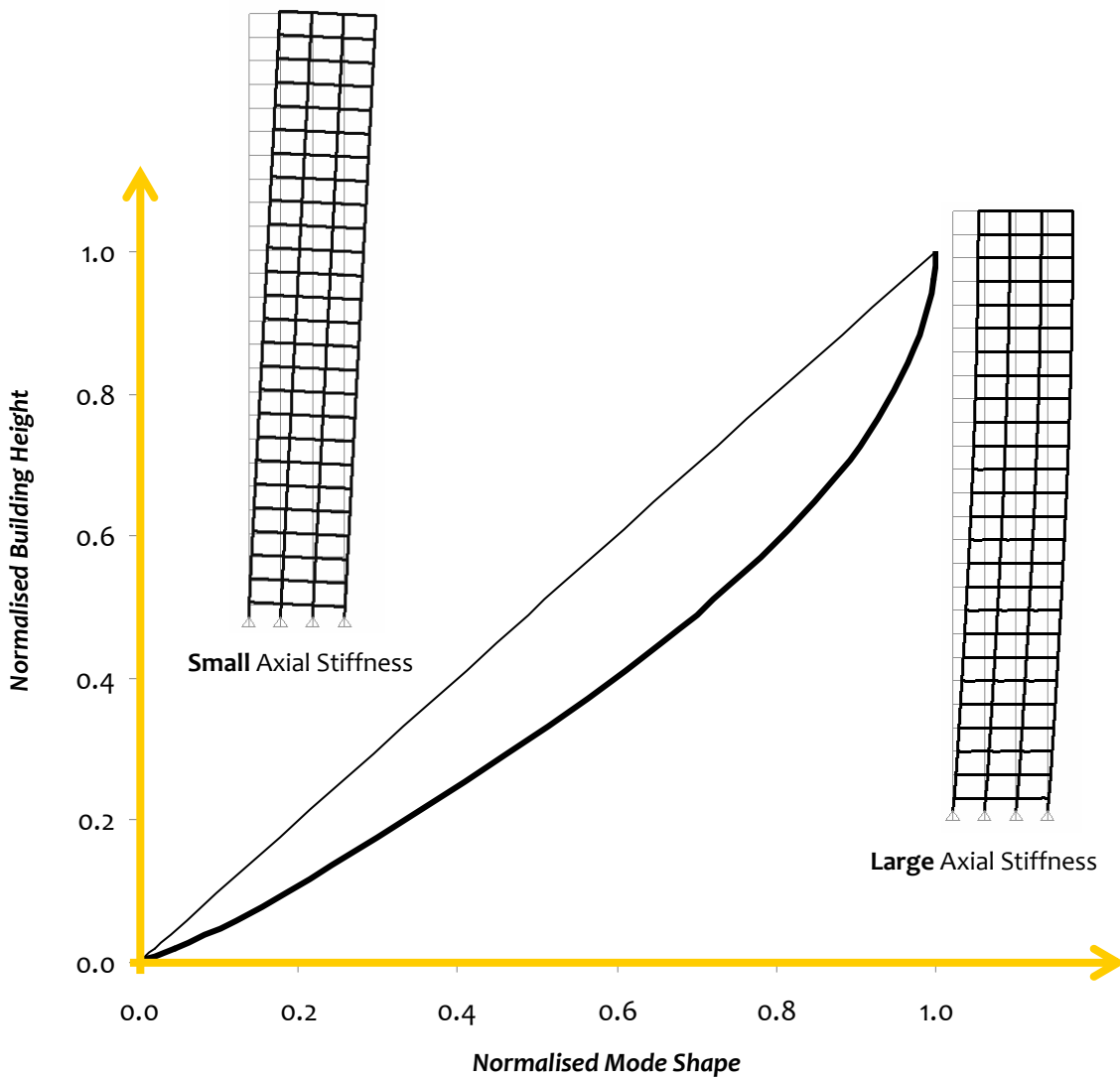
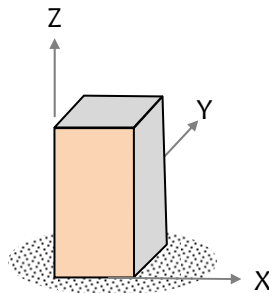


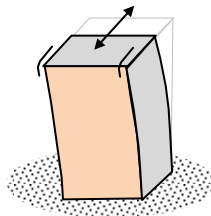
Figure 2.20: Effect of axial stiffness of vertical members: Fundamental translational mode shape changes from flexure-type to shear-type with increase in axial stiffness of vertical members.

Animation Set 203

Three-dimensional mode shapes of 25-Storey Buildings Effect of Axial Stiffness of Columns



Fundamental Translation in Y-direction



SMALL Axial Stiffness of Columns
First translational mode in Y-direction

LARGE Axial Stiffness of Columns
First translational mode in Y-direction

Click on the 2 items above to see the animation of the mode shapes
Best when viewed using Windows Media Player

(3) Effect of Degree of Fixity at Member Ends

Two conditions determine the rotational flexibility of columns at the base of the building. The first condition is when the structural design and detailing deliberately creates rotational flexibility at those locations. And, the second is when the flexibility of soil underneath the footings of columns allows rotation of the columns; this happens when individual footings are used. Highly flexible soils make column bases as good as hinged, and rocky layers below as good as fixed. The extent of fixity at column bases controls overall behaviour of buildings (Figure 2.21). Lack of rotational fixity at column base (hinged condition) increases the lateral sway in the lower storeys than in higher storeys, and the overall response of the building is more of shear-type (Figure 2.21a). On the other hand, full rotational fixity at column base restricts the lateral sway at the first storey and thus, induces initial flexural behaviour near the base (Figure 2.21b). The overall response of the building is still of shear-type due to flexural stiffness of beams (Figure 2.21c). The problem is aggravated in buildings with structural walls. When the base of a structural wall *alone* rests on a mat foundation, the wall experiences rotational flexibility if the soil is flexible. This can lead to unduly large lateral displacement of the building. Also, the lateral force attracted by such walls is significantly reduced.

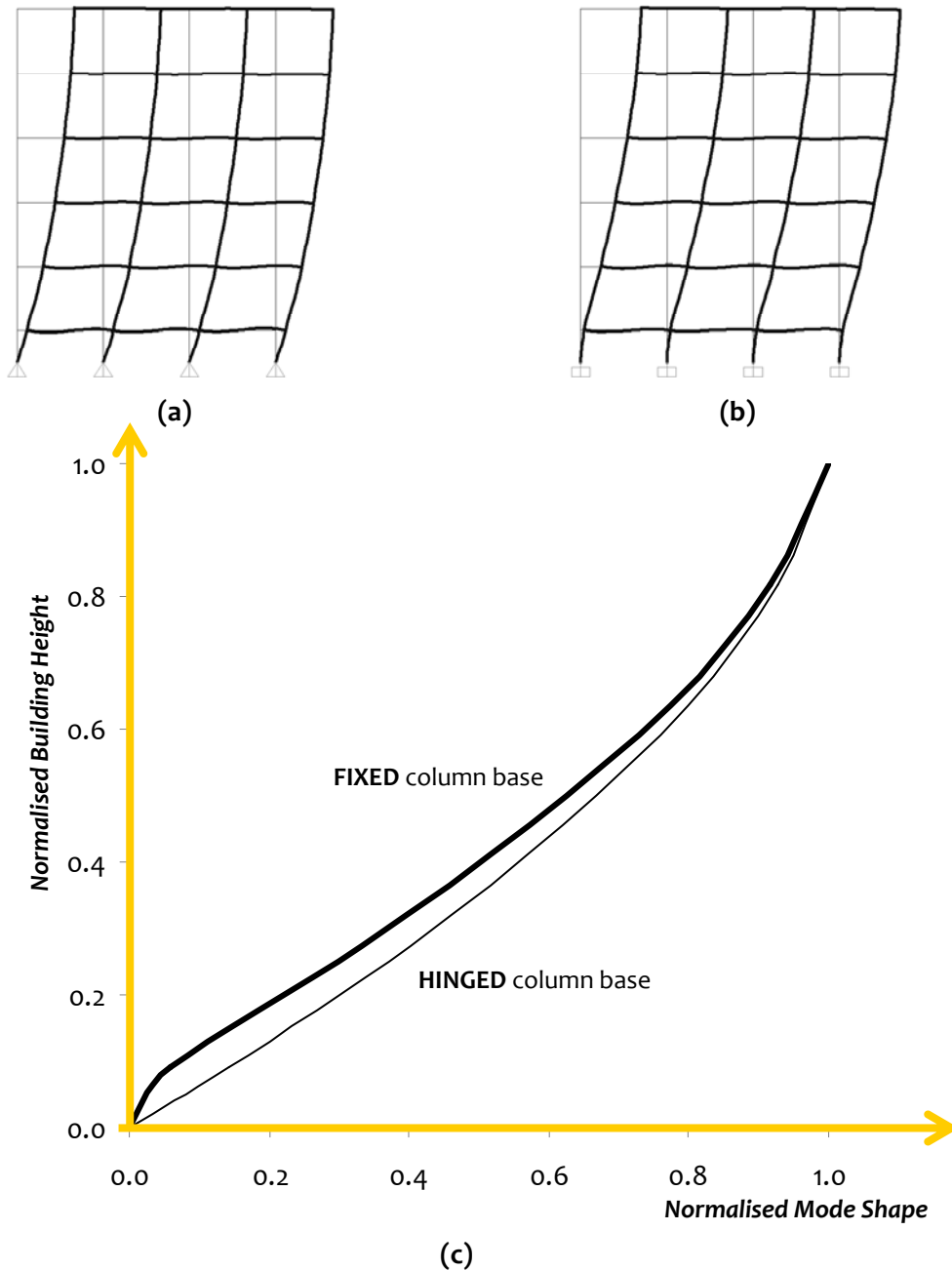
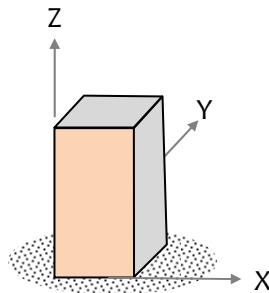


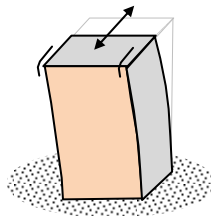
Figure 2.21: Effect of degree of fixity at member ends: Lack of fixity at beam ends induces flexural-type behaviour, while the same at column bases induces shear-type behaviour to the fundamental translational mode of oscillation

Animation Set 204

Three-dimensional mode shapes of Benchmark Building Effect of Rotational Fixity of base of Ground Storey Columns



Fundamental Translation in Y-direction



HINGED Column Bases

First translational mode in Y-direction

FIXED Column Bases

First translational mode in Y-direction

Click on the 2 items above to see the animation of the mode shapes
Best when viewed using Windows Media Player

(4) Effect of Building Height

In well-designed low height moment frame buildings, the fundamental translational mode of oscillation is of shear-type. Buildings become laterally flexible as their height increases. As a result, the natural period of buildings increase with increase in height. However, the fundamental mode shape does not change significantly (from shear type to flexure type). Flexural type behaviour is exhibited only near the lower storeys where the axial deformation in the columns could be significant, particularly in tall buildings. However at higher floor levels, the response changes to shear type as the axial load level lowers. The shapes of fundamental mode of a 5-storey, 25-storey and 40-storey building show the same trend, although the fundamental periods are significantly different (Figure 2.22); the fundamental translational natural periods of these three buildings are 0.89s, 3.14s, and 3.45s, respectively.

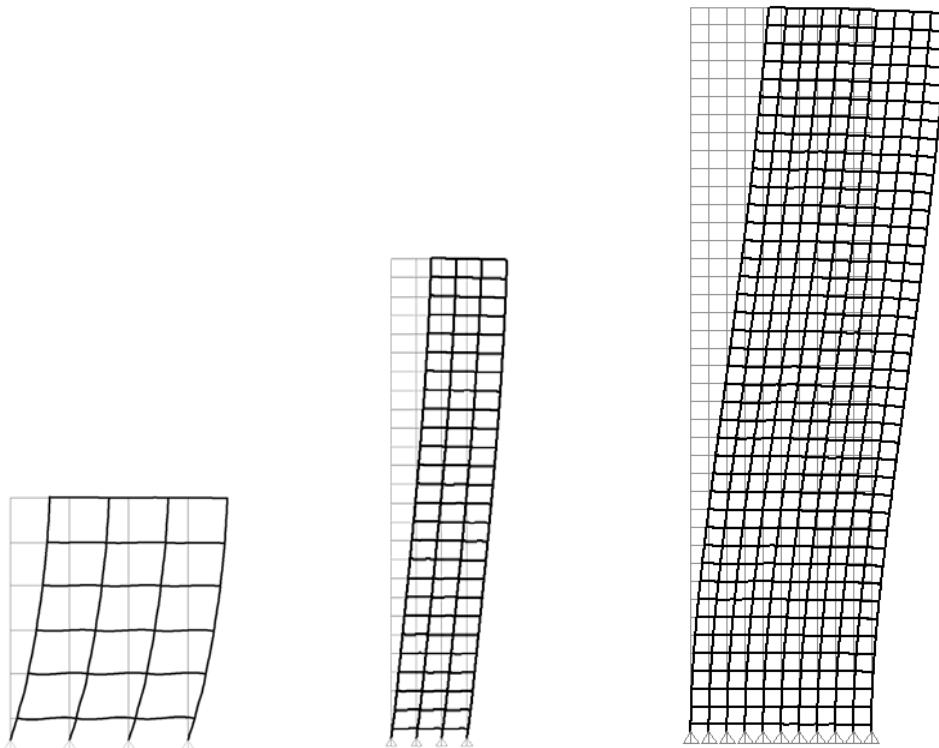
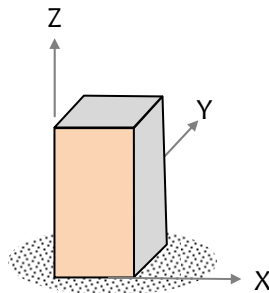


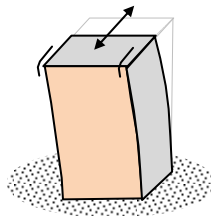
Figure 2.22: *Effect of building height:* Fundamental translational mode shape of oscillation does not change significantly with increase in building height, unlike the fundamental translational natural period, which does change

Animation Set 205

Three-dimensional mode shapes of Benchmark Building Effect of Building Height



Fundamental Translation in Y-direction



5-storey Benchmark Building
First Translational Mode in Y-direction

25-storey Benchmark Building
First Translational Mode in Y-direction

40-storey Benchmark Building
First Translational Mode in Y-direction

Click on the 3 items above to see the animation of the mode shapes
Best when viewed using Windows Media Player

(5) Effect of Unreinforced Masonry Infill Walls in RC Frames

URM infill walls are not considered in analysis and design of RC frame buildings in current design practice in many countries. They are assumed to not carry any vertical or lateral forces, and hence, declared as *non-structural elements* insofar as transfer of forces is concerned between structural elements (e.g., beams and columns) that are generated in the building during earthquake shaking. This assumption causes a large gap between the building that is considered in *analysis* and *design*, and that finally *constructed* (Figure 2.23). This is attributed to the fact that URM infills interfere with lateral deformation of beams and columns of buildings during earthquake shaking (Figure 2.24), and significantly influence seismic behaviour of buildings by participating in lateral force transfer (Figure 2.25). Analytical modeling of buildings for use in seismic design should reflect the true physical behaviour of buildings during earthquake shaking. India has a relatively new RC frame building typology in which this is violated. The typology consists of ground storey of RC frame buildings left open to accommodate parking (Figure 2.26a). The 2001 Bhuj (India) earthquake reiterated that this assumption is invalid (Figure 2.26b), wherein over 430 such buildings collapsed even at intensities of shaking of about VII on the MSK scale. In RC moment frame buildings, stiffness and strength of all likely to participate in the lateral force transfer mechanism should be included at appropriate locations while preparing the analytical model used in design process. This ensures consistency between the building model assumed in analysis and design, and the conditions of the actual structure.

Mode shape of a building depends on the distribution of lateral storey stiffness along the height of the building. As a consequence, it also depends on factors which may affect lateral storey stiffness. Role of URM infill walls discussed above is a major factor that influences lateral storey stiffness of a building. Enhancement of lateral storey stiffness depends on the extent and distribution of URM in each storey. Mode shape of building is affected the least when the lateral storey stiffness (after accounting for the stiffness contribution from URM infill walls) is constant throughout the height of the building; it is affected the most, when the lateral storey stiffness (after accounting for the stiffness contribution from URM infill walls) differs significantly between any two consecutive storeys. In a building with an open ground storey, the lateral storey stiffness of the bottom storey is significantly smaller from that of the storeys above. Consequently, the mode shape of the building is greatly affected by the presence of open ground storey (Figure 2.27). Hence, the mode shape arrived at without considering lateral stiffness contribution of URM infill walls is significantly different than that arrived at by considering it, or the actual mode of such a building.

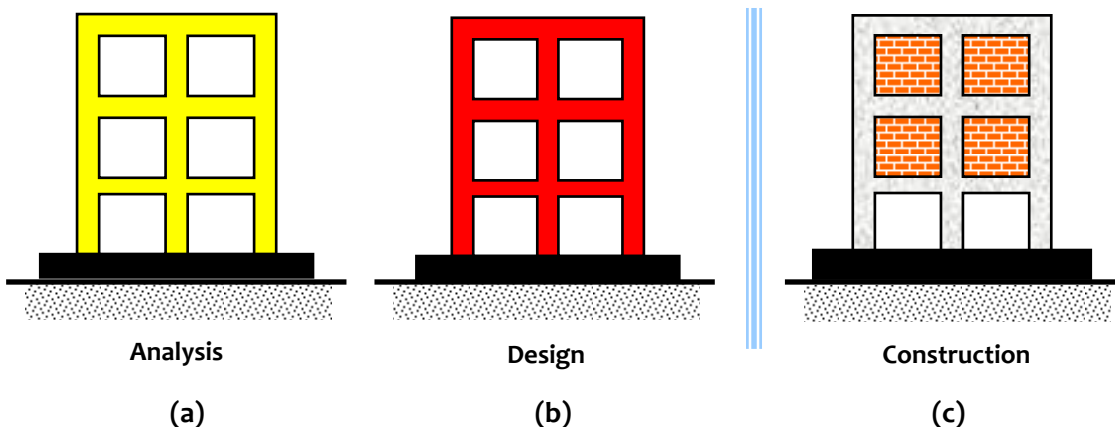


Figure 2.23: Unreinforced Masonry Infill Walls in RC Frame buildings: (a) Analytical model considered in structural analysis and structural design, and (b) Actual structure constructed

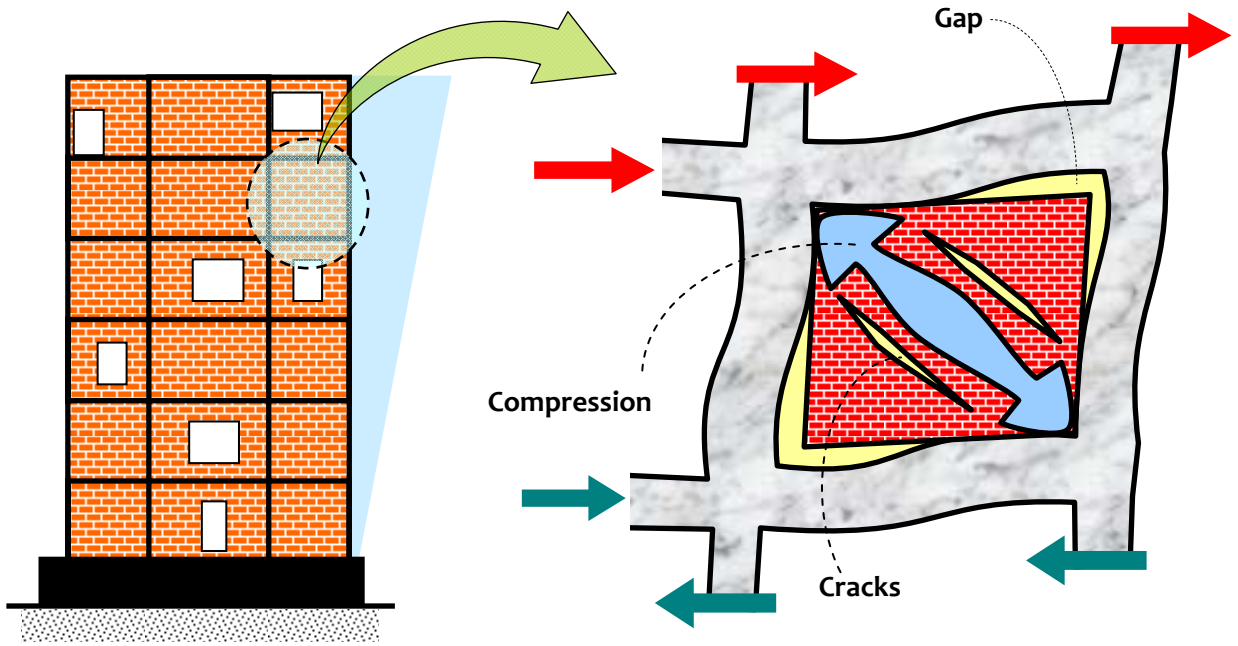


Figure 2.24: Deformation of RC frame Building with URM Infill Walls - there is non-uniform contact along the perimeter of the URM Infill Wall panel during earthquake shaking

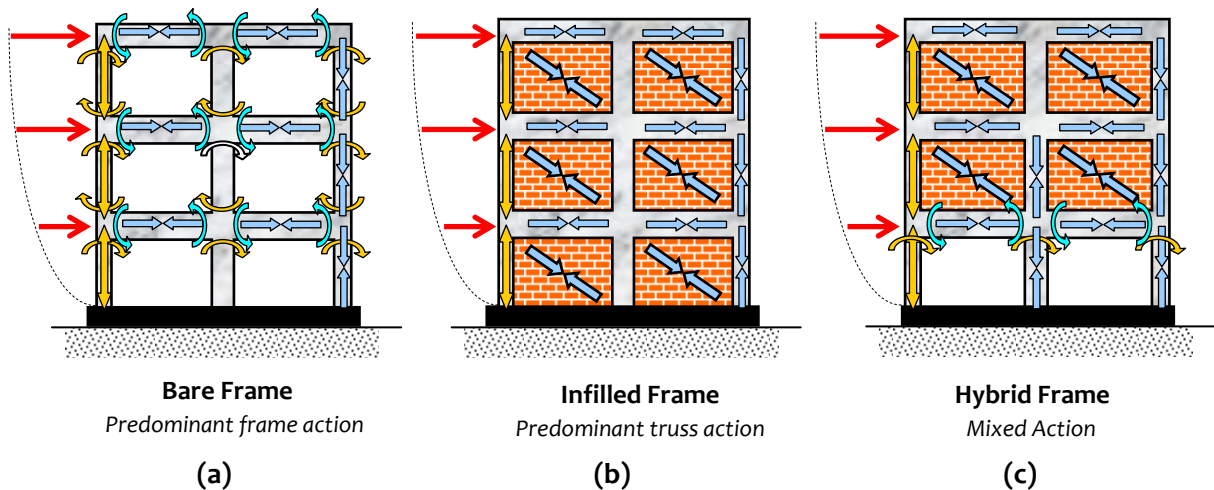


Figure 2.25: Lateral Force Transfer Mechanism in RC Frame Buildings - (a) Bare Frame, (b) Frame with URM Infill Walls in all storeys, and (c) Frame with no URM Infill Walls in ground storey.



(a)



(b)

Figure 2.26: *Open Ground Storey Buildings in Seismic Areas* – (a) A typical housing typology in practice in the urban areas of India (e.g., Chandigarh (Punjab, India)), and (b) RC Frame buildings with open ground storeys collapsed (left unit one and right unit two) in Gandhidham (Gujarat, India) during the 2001 Bhuj (India) Earthquake

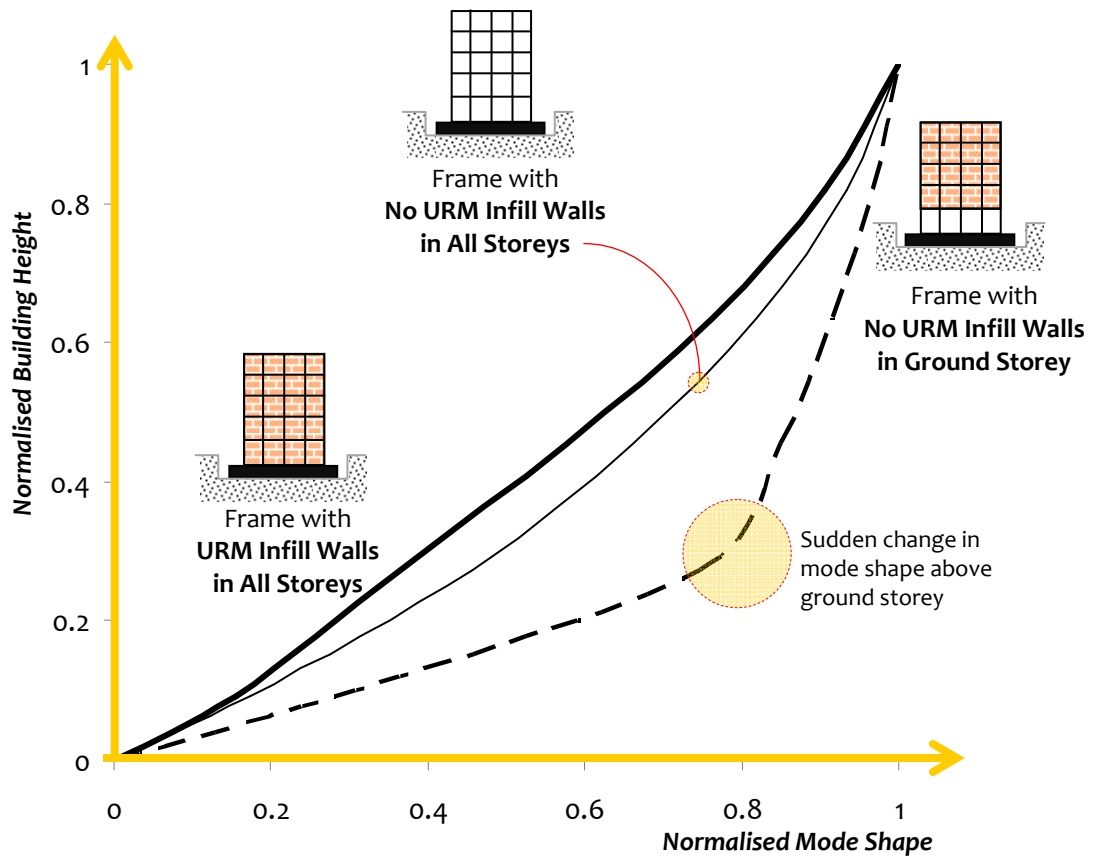


Figure 2.27: Influence of URM Infill Walls in Mode Shape of RC frame Buildings – Mode shape of a building obtained considering stiffness contribution of URM is significantly different from that obtained without considering the same

(c) Design Practice

Design engineers need to control both the mass and stiffness of buildings. They should use this freedom to tune the stiffness of the building in the two plan directions X and Y in such a way that:

- (1) The fundamental modes of oscillation are the translational natural modes of oscillation, and that too are the pure translational mode shapes and NOT diagonal or torsional oscillations.
- (2) All torsional modes of oscillation and mixed (torsional-cum-translational) modes of oscillation, if any, are pushed to possess natural periods outside the range 0.04-2.00s, by increasing the torsional stiffness of the building through the introduction of structural walls along the perimeter of the building.
- (3) Buildings are not made structurally bi-symmetric in the two plan directions (even though, they may be architecturally bi-symmetric in plan) resulting in the same natural period for the two pure horizontal translational modes of oscillation. No two natural periods of pure translational modes of vibration should be within 15% of the larger natural period. This 15% limit is arrived at to ensure that the width of the peak response (taken as that corresponding to 70% of peak response as defined by *half power method* for estimating damping) at a certain natural period does not overlap with that at the adjacent natural period (Figure 2.28b).
- (4) The axial stiffness of the vertical elements is high, to ensure shear-type lateral translational mode shape of oscillation. This will result in reduced overall lateral deformation of the building. Further, this reduces axial stresses in the vertical members, which in turn reduces the rate of corrosion in RC columns. And, the axial load level of the design point in the *P-M* interaction space of RC column sections is kept below $P/P_{uz} < 0.3$, to ensure that columns undergo ductile behaviour with tension failure in steel, than compression failure when P/P_{uz} is large.

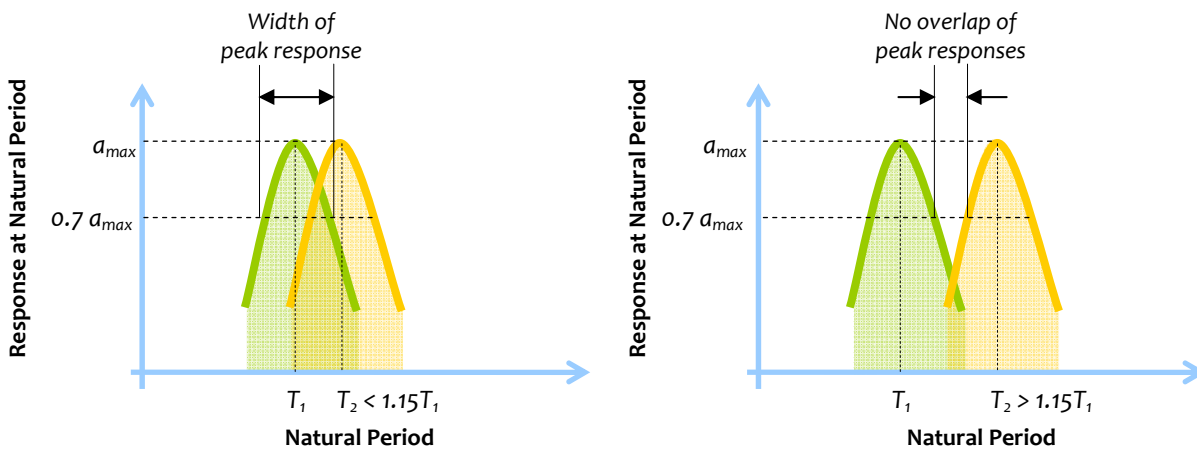


Figure 2.28: Proximity of Natural Modes: Combined Response of two adjacent modes should be avoided

2.2.3 Damping

Buildings set to oscillation by earthquake shaking eventually come back to rest with time. This is due to dissipation of the oscillatory energy through conversion to other forms of energy, like heat and sound. The mechanism of this conversion is called *damping*. In normal ambient shaking of building, many factors impede its motion, *e.g.*, drag from air resistance around the building, micro-cracking of concrete in the structural members, and friction between various interfaces in the building (like masonry infill walls and RC beams and columns). This damping is called *structural damping*. But, under strong earthquake shaking, buildings are damaged. Here, reinforcement bars and concrete of the RC buildings enter nonlinear range of material behaviour. The damping that arises from these inelastic actions is called *hysteretic damping*; this further dampens oscillations of the building. Another form of damping is associated with soil. This damping occurs when the soil strata underneath the building is flexible and absorbs energy input to the building during earthquake shaking, and sends it to far off distances in the soil medium. This is called *radiation damping*.

Modeling damping mathematically is a major challenge; many models were proposed, *e.g.*, *friction damping*, *viscous damping* and *hysteretic damping*. Of these, design practice uses the mathematically simplest of them, namely viscous damping. Damping is expressed as a fraction of the critical damping (which is the minimum value of damping at which the building gradually comes to rest from any one side of its neutral position without undergoing any oscillation). Damping is said to be different for different natural modes of oscillation of a building. But, Indian seismic codes recommends the use of 5% damping for all natural modes of oscillation of reinforced concrete buildings, and 2% for steel structures.

The time histories of lateral displacement of roof of 25-storey building H are shown in Figure 2.29 for three values of viscous damping of 0.5%, 5% and 20% of critical, when subjected to an earthquake ground motion at the building base; the amplitude and duration of oscillation decreases with increase in damping.

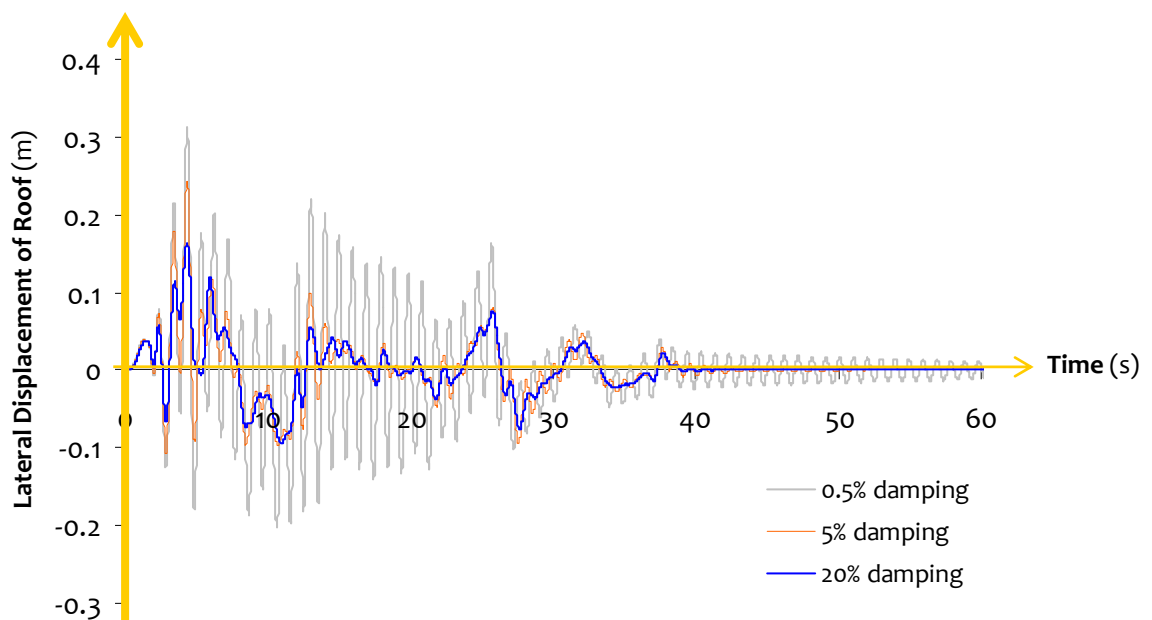
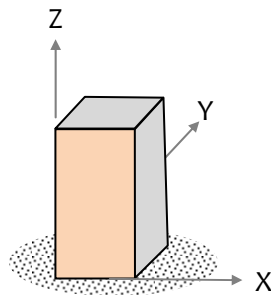


Figure 2.29: *Effect of damping:* Amplitude of oscillation reduces with increase in damping

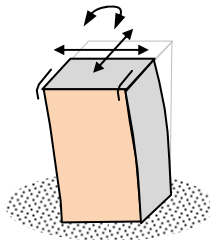
Animation Set 206

Time histories of deformations of Benchmark Building
under 1940 Imperial Valley earthquake ground motion (El Centro So0E component)

Effect of Damping



Three-dimensional Shaking of Benchmark Building



0.5% of Critical Damping

Three-dimensional deformation (relative to the ground)

5% of Critical Damping

Three-dimensional deformation (relative to the ground)

20% of Critical Damping

Three-dimensional deformation (relative to the ground)

Click on the 3 items above to see the animation of the deformed shapes

Caution: These are large files (~80Mb each)

Best when viewed using Windows Media Player

2.3 GROUND MOTION CHARACTERISTICS

Earthquake originates below the surface of the earth due to rupture of bed-rock. This is associated with release of stored strain energy that spreads out in all directions from the fault region in the form of seismic waves that travel through the body and along the surface of the Earth. These seismic waves, primarily of two types called the *body waves* and *surface waves*, together cause shaking of the ground (surface of the Earth) on which the buildings are founded. The characteristics of the ground shaking control earthquake response of buildings, in addition to the building characteristics.

The ground motion can be measured in the form of *acceleration*, *velocity* or *displacement*. Earth scientists are interested in capturing the size and origin of earthquakes worldwide, and measure feeble ground displacements even at great distances from the epicenter of the earthquakes. Instruments that measure these low level displacements are called *Seismographs*. In the vicinity of the epicenters of large earthquakes, the ground shaking is violent. Seismographs get saturated, as their design is such that they get saturated under large displacement shaking, and become ineffective in capturing the displacement of the ground. And, on the other hand, engineers are interested in studying levels of ground shaking at which buildings are damaged, and are conversant with forces (as part of the design process of building). Hence, this motivated the development of instruments called *Accelerographs*, that record during the earthquake shaking acceleration as a function of time of the location where the instrument is placed. These instruments successfully capture the ground shaking even in the near field of the earthquake faults, where the shaking is violent.

2.3.1 Accelerograms

The record obtained from an accelerograph, *i.e.*, the variation of ground acceleration with time recorded at a point on ground during an earthquake, is called an *accelerogram*. Three accelerograms are recorded simultaneously along three mutually perpendicular directions to capture the complete oscillation of the ground at a location (called a *station*). These three records of three mutually perpendicular correspond to two along the horizontal directions and one along the vertical direction.

The nature of accelerograms vary depending on energy released, type of rupture at the bed rock, geology along the travel path from source to the Earth's surface, and local soil. Accelerograms carry distinct information regarding ground shaking, namely *peak amplitude*, *duration of strong shaking*, *frequency content* (namely the frequencies at which the earthquake carries significant shaking energy). Type of rupture, the geology along the travel path, geotechnical strata under the building are three critical factors that determine the characteristics of acceleration ground motion at a station (Figure 2.30).

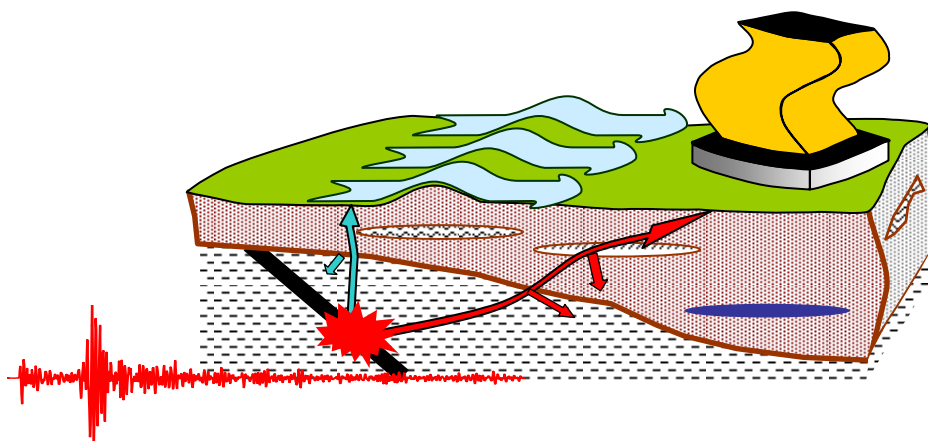


Figure 2.30: Ground shaking during earthquakes: Many reflections and refractions occur along the path, and filtering of frequencies occurs especially under the building

Peak amplitude, representing the *peak ground acceleration* (PGA), is an important design parameter. For instance, a horizontal PGA value of 0.6g (*i.e.*, a peak ground acceleration of 0.6 times the acceleration due to gravity g) suggests that the shaking of the ground can cause a rigid building to sustain a maximum horizontal inertia force of 60% of its weight (*i.e.*, one with fundamental natural period T close to zero). Horizontal PGA values of about 1.82g were recorded during the 1994 Northridge Earthquake in USA.

The duration of shaking corresponds to that part of the ground oscillation that is above the normal level of ambient vibration of the ground at the station. For a building that remains elastic during the entire earthquake shaking, the duration of earthquake shaking may not make a difference. But, for another building that accrues damage during earthquake shaking, the duration of earthquake shaking does make a significant difference. Under these inelastic conditions of the building, all three factors make a difference, namely *peak ground acceleration*, *duration of strong shaking* and the *frequency content*. Figure 2.31 gives a collection of ground motions with different features (all of them scaled to the same time and amplitude axes).

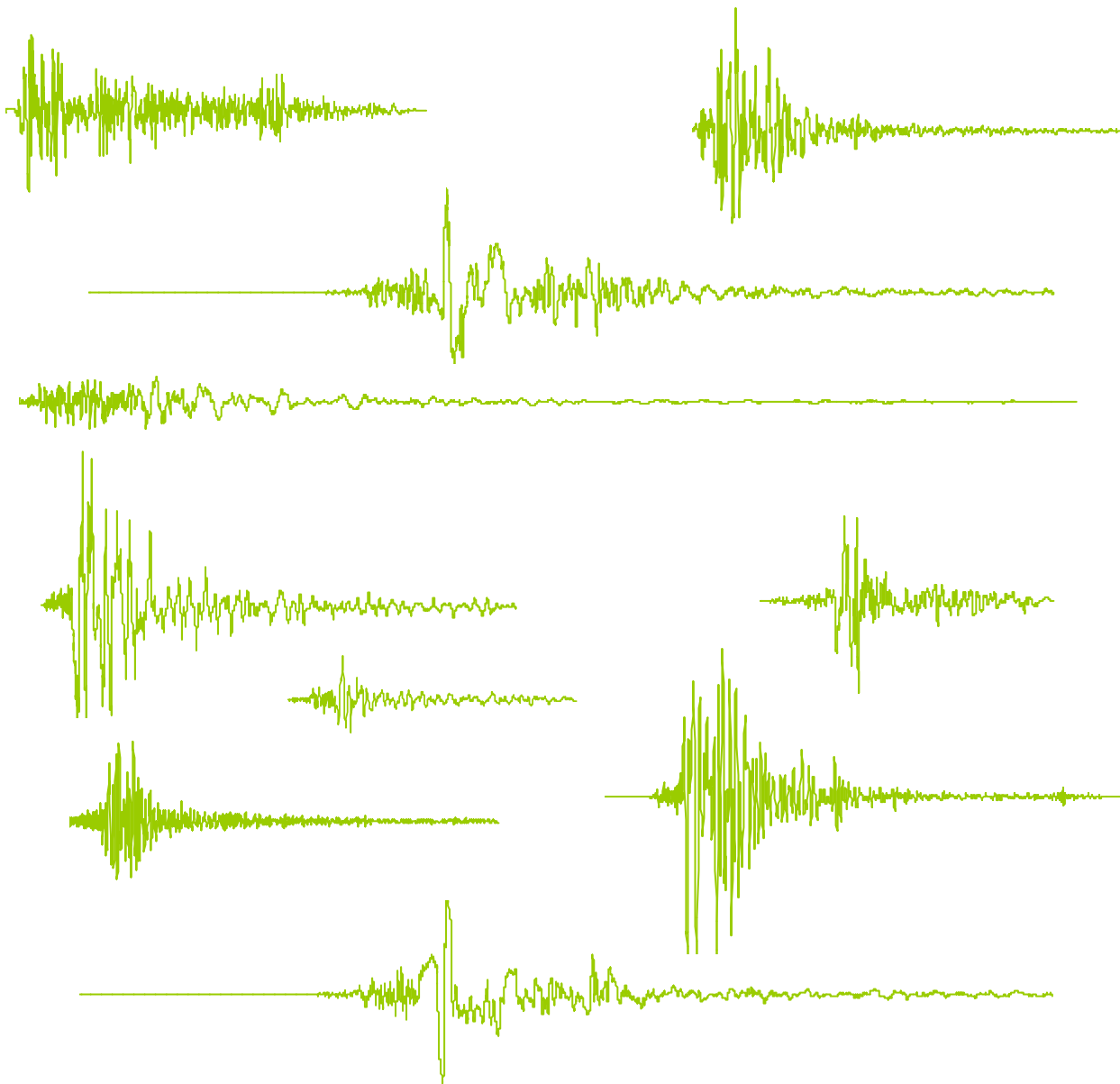


Figure 2.31: Qualitative difference in acceleration time histories of ground motions: These were recorded during past earthquakes worldwide

2.3.2 Response Spectrum of a Ground Motion

A building can be mathematically conceived to be a collection of equivalent simple structures each having only one natural period of oscillation, corresponding to one of the modes of oscillation of the building. These are called the *equivalent single-degree-of-freedom (SDoF) structures* corresponding to *each mode of oscillation of the original building* (Figure 2.32).

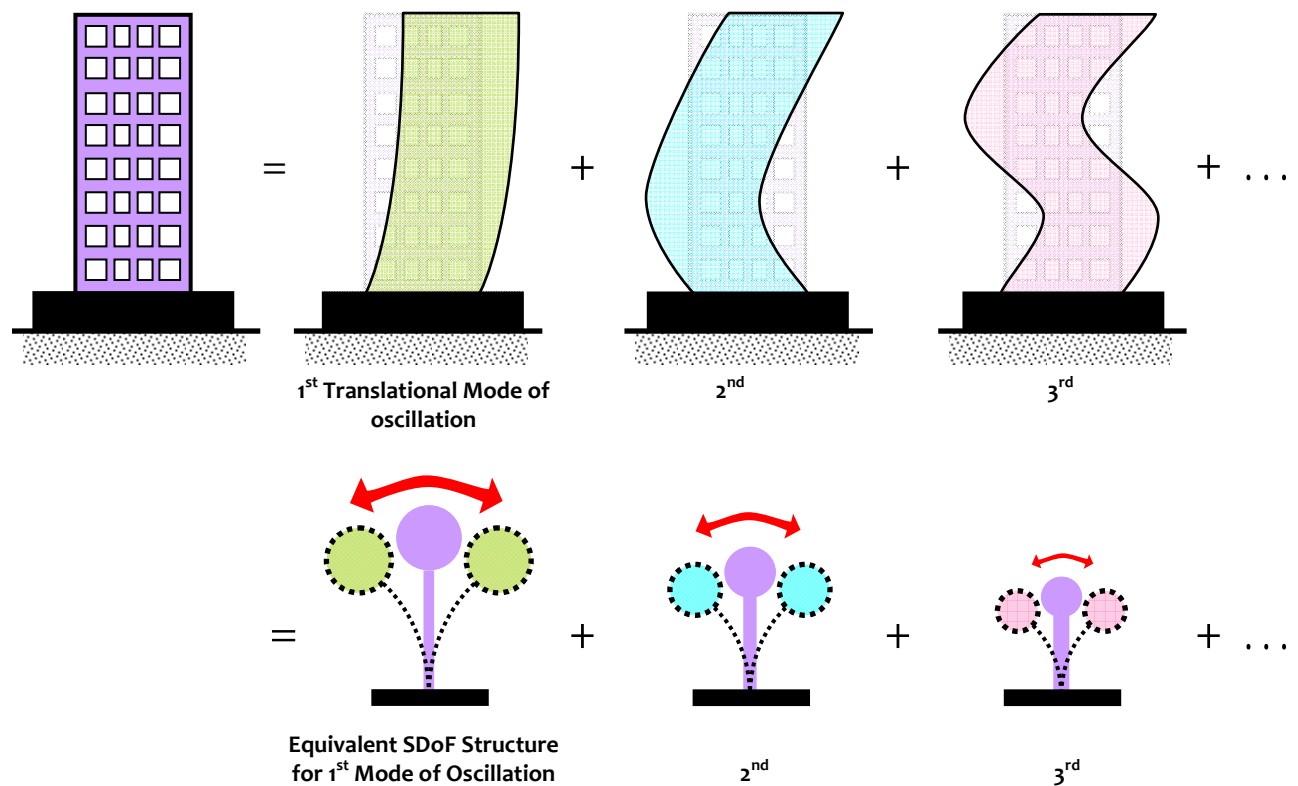


Figure 2.32: Equivalent SDoF structures corresponding to each mode of oscillation of the building: Decomposing the response of the building for purposes of understanding behaviour and of undertaking design calculations

A single-degree-of-freedom structure has mass m , stiffness k and associated structural damping ξ . Its natural period also is as given by Eq.(2.1). Thus, all the single-degree-of-freedom structures with same proportion of mass and stiffness (Figure 2.33) have the same natural period of $2\pi\sqrt{m/k}$. Such a set of structures with same natural period (or frequency) of oscillation and same structural damping ξ exhibit same time history of response (*i.e.*, acceleration, velocity and displacement), when subjected to the same earthquake ground shaking. Thus, it is convenient to identify before hand the possible responses of a number of such SDoF structures with different natural periods (but same damping) when subjected to *one* earthquake ground shaking.

This is useful in studying different buildings in a region subjected to same ground motions and understand their response (Figure 2.34a). One can hypothetically consider mounting buildings of different dynamic characteristics (say, T) on a railway wagon and shake the same with a uniform ground motion. Expectantly, the response of different buildings will be different because they receive different input energies from the same earthquake (Figure 2.34b). Now, replace the buildings on the wagon with their corresponding SDoF structures corresponding to their fundamental lateral translational modes of oscillation; the results indicate different responses to the same ground motion (Figure 2.35).

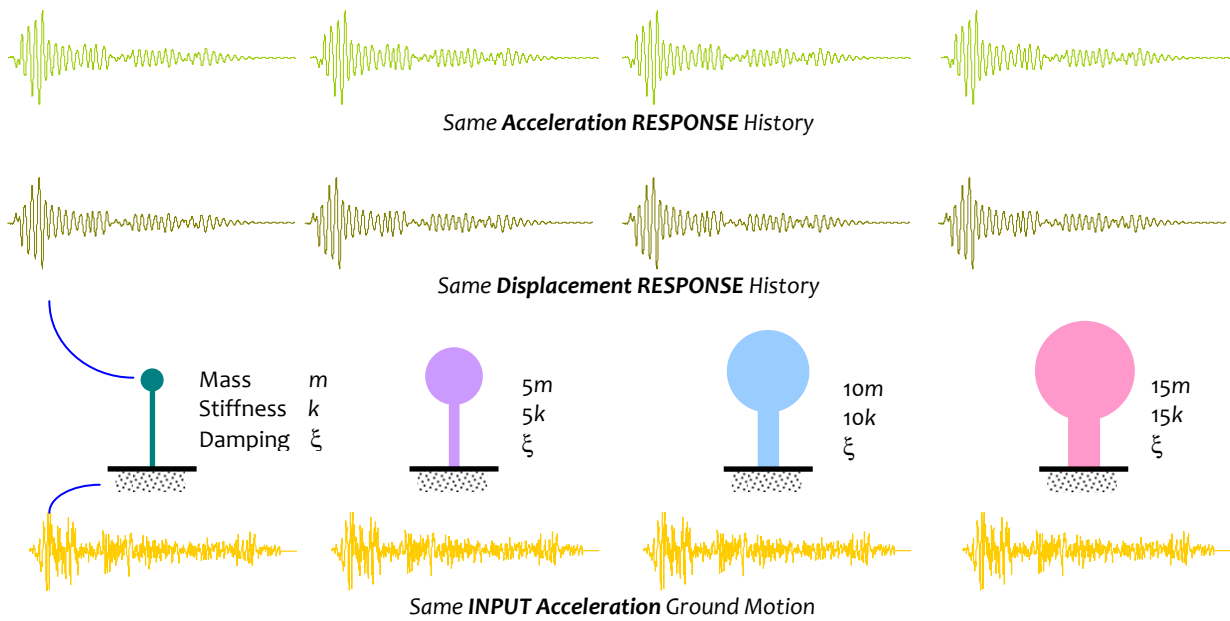


Figure 2.33: *Dependence of Response on Natural Period:* Time history of acceleration and displacement of mass is same for a number of structures with same natural period when subjected to the same earthquake shaking, and with same damping

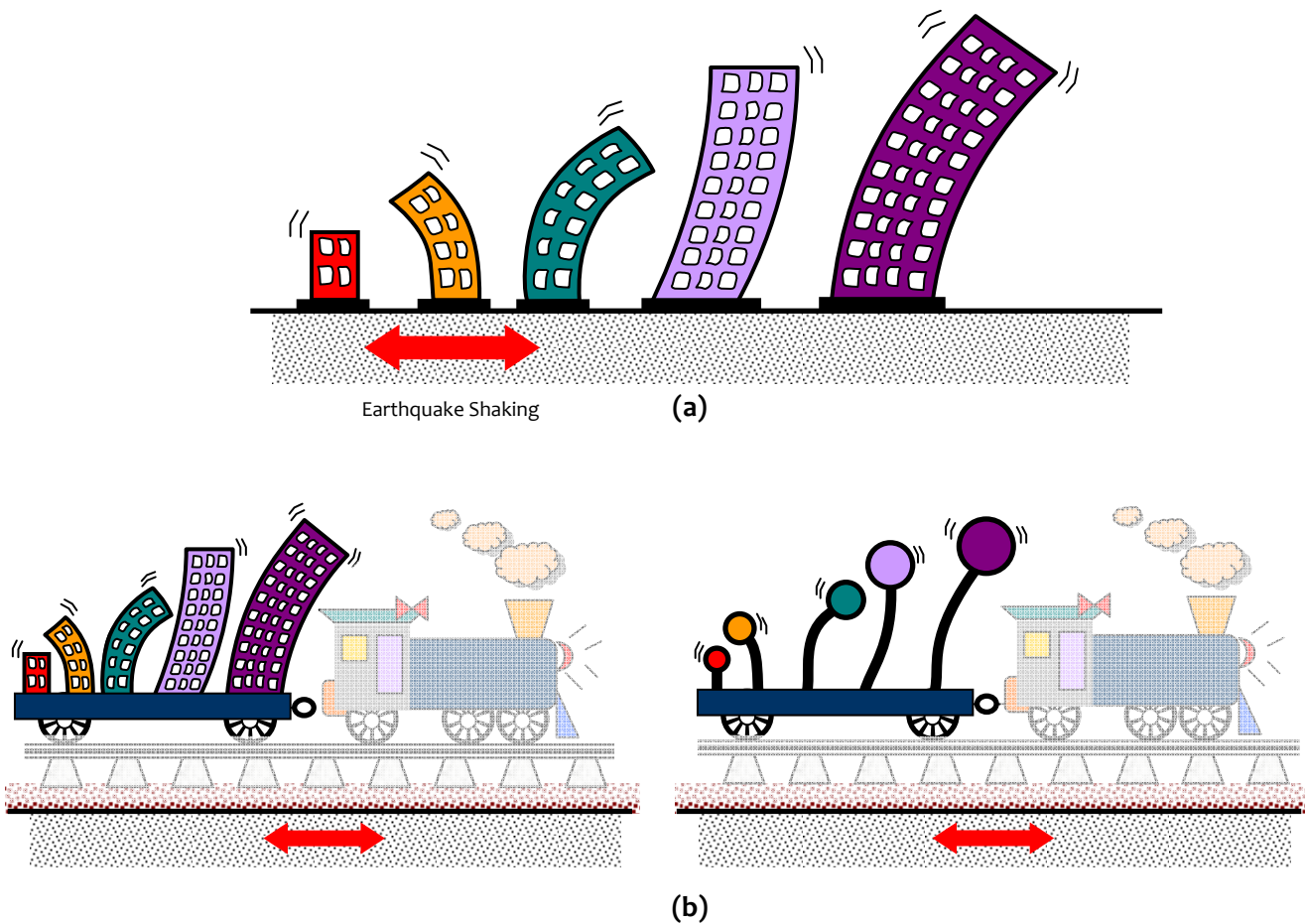


Figure 2.34: *Dependence of Response on Natural Period:* Time history of acceleration and displacement of mass is same for a number of structures with same natural period when subjected to the same earthquake shaking, and with same damping.

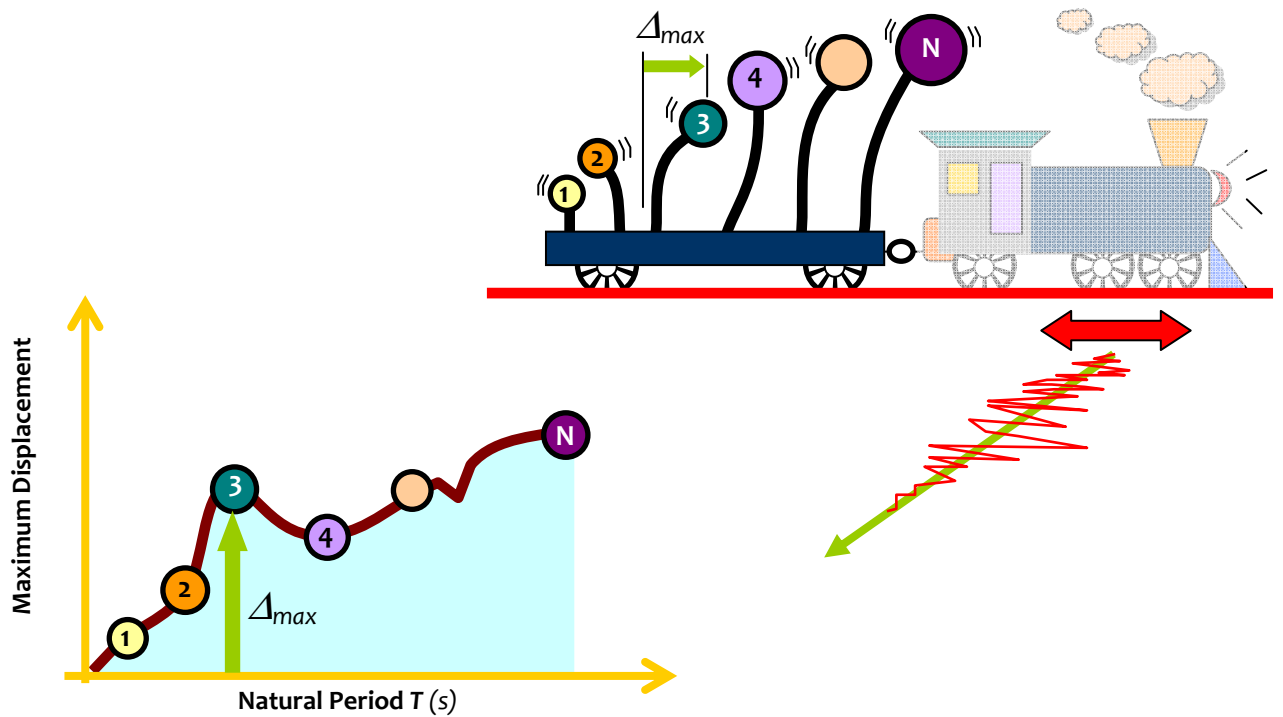


Figure 2.35: Influence of same ground motion on buildings with different fundamental translational Natural Period: When the energy content in the earthquake is higher corresponding to the fundamental translational natural period of a building, it shows higher response

(a) Acceleration Response Spectrum of a Ground Motion

Usual seismic design of structures is performed using the *maximum force induced* in the structure due to earthquake shaking. Force can be defined in two ways: (i) mass m times acceleration a , representing *inertia force*, or (ii) stiffness k times displacement x representing *elastic force*, i.e.,

$$F = ma \text{ or } F = kx . \quad (2.4)$$

Further, since absolute maximum of such response is useful in design, a graph of the maximum response is generated for a spectrum of SDoF structures with different natural periods T and the same damping under the same earthquake ground motion. This graph is called the *Response Spectrum* of the particular earthquake ground motion. One such response spectrum corresponding to the acceleration of the building, called the *acceleration response spectrum*, is shown in Figure 2.36 for 5% damping under the action of 1940 Imperial Valley earthquake ground motion (El Centro; S00E component).

In real buildings, it is easier to compute the mass of the building that is effective during earthquake shaking, called *seismic mass* (equal to seismic weight divided by acceleration due to gravity g), than to evaluate overall stiffness. Thus, once the natural period associated with each mode of oscillation is estimated, the corresponding seismic lateral force is obtained by multiplying the acceleration response spectrum value (from the acceleration response spectrum) with the mass associated to each mode of oscillation. In the design of buildings, seismic design codes provide a *design response spectrum* and the corresponding force obtained is called the *design seismic lateral force* of the building or the *design seismic base shear* of the building.

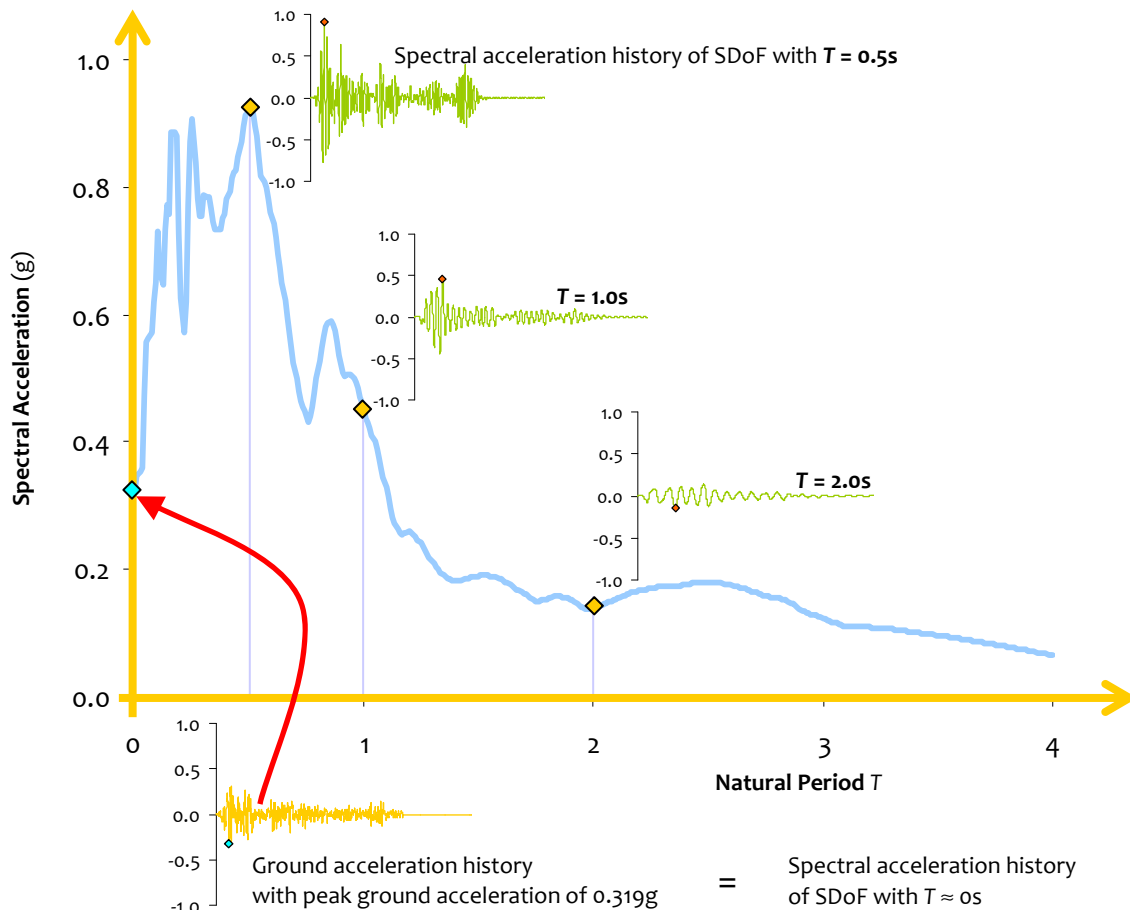


Figure 2.36: Acceleration Response Spectrum of a ground motion: Absolute maximum acceleration (or spectral acceleration) response of a spectrum of structures with different fundamental translational natural periods, but with the same damping and subjected to the same considered ground motion

(b) Design Practice

The generation of acceleration response spectrum and a change of frame of reference of deformation together have facilitated converting the moving base problem of earthquake shaking of buildings into a fixed base problem (Figure 1.13). The latter is easy to handle, since design practice is conversant with analysis and design of structures subjected to *forces*, and not subjected to *displacements* or *accelerations*. Therefore, the acceleration response spectrum allows quick, back-of-the-envelope type calculations by senior engineers to check the ball park values of force generated in a building during earthquake shaking.

Design codes use a *Design Acceleration Response Spectrum*, which is derived from the *Acceleration Response Spectrum* of many individual ground motions. Loosely speaking, the *Design Acceleration Response Spectrum* is the smoothed envelope of all *Acceleration Response Spectra* of the ground motions for which the building is expected to be designed. In the strict sense, *Design Acceleration Response Spectrum* is different for each location in the country, since the seismic wave actions are different at different locations in the country. But, it would be tedious if designers are required to obtain this design spectrum by themselves for the design of individual buildings in a country. Hence, design codes prescribe that the same *Design Acceleration Response Spectrum* be used throughout the country. Only one correction is made related to the soil conditions at the site. Soft soils are expected to shake more violently, and hence the *Design Acceleration Response Spectra* are different for them. This *Design Acceleration Response Spectrum* prescribed by codes is a spectrum recommended for use in the design of simple, regular and normal buildings. For the design of special buildings (e.g., tall buildings), a *Design Acceleration Response Spectrum* should be arrived at specific to the site where the special building is being constructed.

Chapter 3

Earthquake Capacity of Buildings - Elastic Behaviour

3.1 ELASTIC BEHAVIOUR

Elastic earthquake behaviour of buildings is primarily controlled by configuration and stiffness, out of the four virtues of *configuration, stiffness, strength* and *ductility*. Thus, only the effects of *seismic structural configuration* and *lateral stiffness* on *elastic* seismic performance of buildings are discussed in this Chapter. All buildings discussed in this Chapter are designed for full gravity load and lateral load equal to 10% of the total building weight to illustrate various concepts of elastic behaviour of buildings; the actual design lateral force of similar buildings will depend on many factors, like seismic zone, and type of framing system, as specified by the design codes. The total lateral force is distributed over the building height and plan using provisions given in the *Indian Seismic Code IS:1893 (Part 1) - 2007*. The code requires all buildings to be designed for a minimum eccentricity. But, in the buildings considered in Chapters 3 and 4, the design lateral force is not applied at this minimum eccentricity specified by the code, to focus on the concept being discussed without being distracted by the implications of torsional behaviour. This departure is made ONLY to bring out *one by one* individual concepts related to elastic behaviour of buildings subjected to earthquake ground shaking; otherwise, the effects of torsional action may cloud the behavioural aspect intended to be in focus.

3.2 CONFIGURATION

Configuration is critical to good seismic performance of buildings. The important aspects affecting seismic configuration of buildings are overall geometry, structural systems, and load paths. Various issues related to seismic configuration are discussed in this section.

3.2.1 Overall Geometry

Buildings oscillate during earthquake shaking and inertia forces are mobilized in them. Then, these forces travel along different paths, called *load paths*, through different structural elements, until they are finally transferred to the soil through the foundation. The generation of forces based on basic oscillatory motion and final transfer of force through the foundation are significantly influenced by overall geometry of the building, which includes: (a) plan shape, (b) plan aspect ratio, and (c) slenderness ratio of the building.

(a) Plan Shape

The influence of plan geometry of the building on its seismic performance is best understood from the basic geometries of *convex-* and *concave-*type lenses (Figure 1.9). Buildings with former plan shape have direct load paths for transferring seismic inertia forces to its base, while those with latter plan shape necessitate indirect load paths that result in stress concentrations at points where load paths bend. Buildings with convex and simple plan geometries are preferred, because they demonstrate superior seismic performance than those with concave and complex plan geometries (Figure 3.1).

To illustrate the above concept, five-storey moment frame buildings with seven plan shapes are considered; six of them have complex plan geometries and one has the simple rectangular geometry (Figure 3.1). Each building has a basic frame grid with columns spaced at 4m, *i.e.*, each unit is of 16m² area. The rectangular building is the same benchmark building discussed in Chapter 2, having plan dimensions of 12m×16m, with 3 and 4 bays in the two perpendicular plan directions (Figure 3.2).

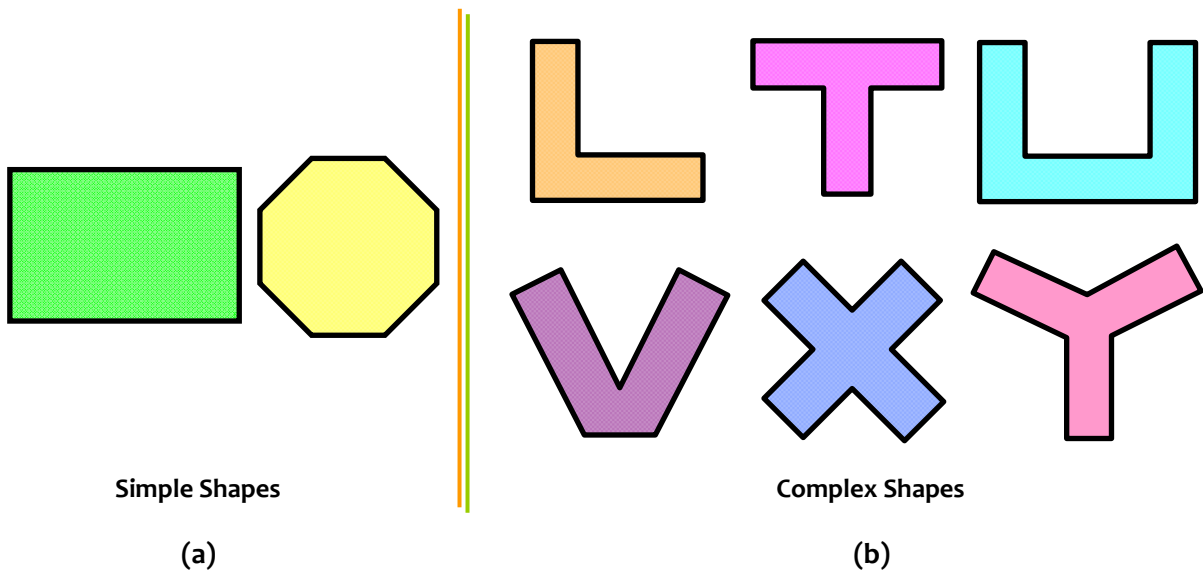


Figure 3.1: *Plan shapes of buildings:* Buildings with (a) simple shapes undergo simple acceptable structural seismic behaviour, while (b) those with complex shapes undergo complex unacceptable structural seismic behaviour

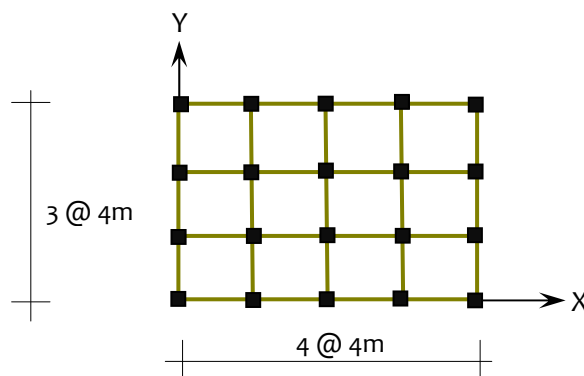


Figure 3.2: *Building unit:* Each building with complex shape is composed of the basic 3 bay by 4 bay rectangular modules with column spacing of 4m in each plan direction

(1) *Buildings with different shapes, but same Plan Area*

Rectangular (or square) columns are good in resisting shear and bending moment about axes parallel to their sides. Thus, it is important to have buildings oscillating primarily along their sides – *translation along diagonals* or *torsional* motions are NOT good for seismic performance of columns, and hence, of buildings (Figure 3.3). Further, in regular buildings, the overall motion is controlled by the first few modes of oscillation; the fundamental mode (corresponding to largest natural period) usually contributes maximum, followed by the 2nd mode, 3rd mode, etc. Thus, it is desirable to have pure translation modes as the lower modes of oscillation and push torsional and diagonal translational modes to the higher ranks. Primarily, these undesirable (diagonal translation and torsional) modes arise when there is lack of symmetry in the plan shape of buildings along the sides. It is important to have regular plan shape of buildings.

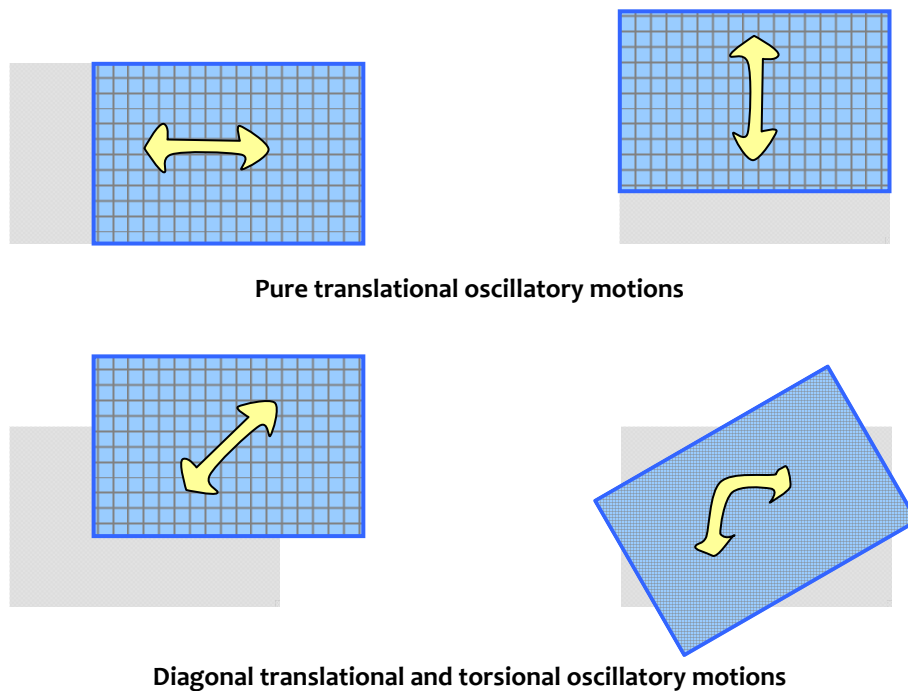


Figure 3.3: Oscillatory motions of buildings during earthquake shaking: Diagonal translational and torsional oscillations are not preferred

Six buildings, without any irregularity in mass or stiffness, but with complex shapes are chosen to compare the effect of plan shape on elastic behaviour of buildings (Figure 3.4). These buildings have approximately the same plan area of about 2496m². The first six modes of oscillation of each of these buildings are compared in Table 3.1, and shown in Figures 3.5 to 3.10.

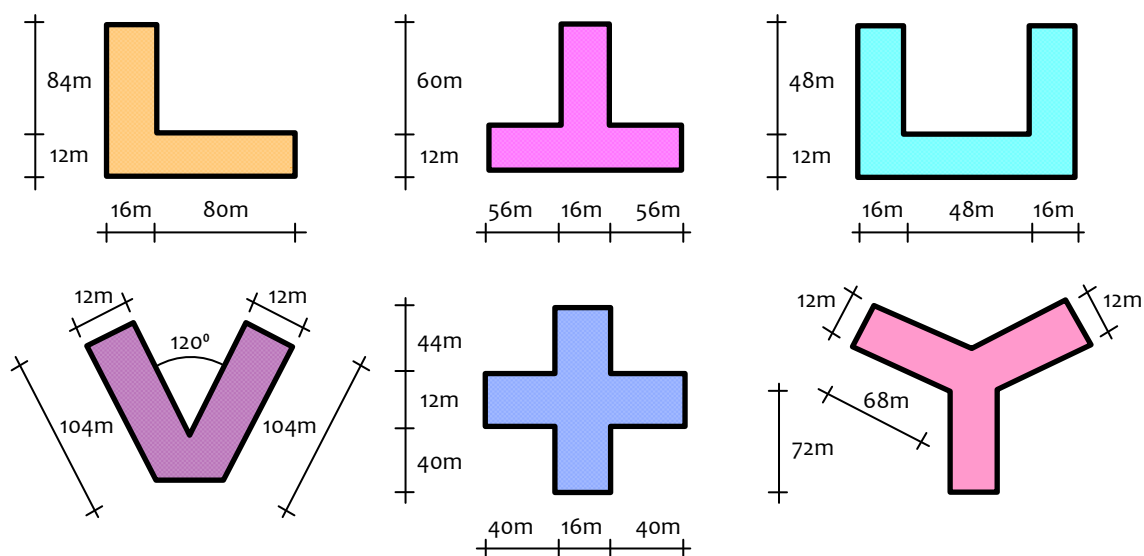
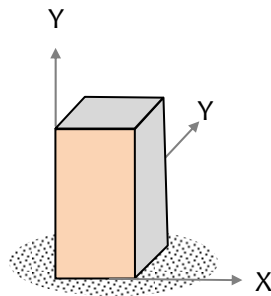


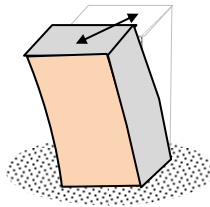
Figure 3.4: Buildings of different plan shapes: These buildings have approximately the same plan area

Animation Set 301

Three-dimensional Modes of Oscillation **Diagonal Translational Modes**



Diagonal Translation



FIRST

Diagonal Translational Mode

SECOND

Diagonal Translational Mode

THIRD

Diagonal Translational Mode



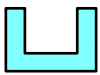

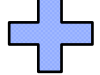

Click on the 3 items above to see the animation of the mode shapes

Best when viewed using Windows Media Player

Note:

Diagonal translation are not acceptable as initial modes of oscillation in buildings

Table 3.1: Modes of oscillation: The first six modes include undesirable oscillations, like *diagonal translation*, *torsion*, *opening-closing*, and *dog-tail-wagging*, in buildings with complex plan shape

Mode	Type of oscillation in first six modes in buildings with different plan shapes					
						
1	Y-translation	Y-translation with torsion	X-translation	Torsion	X-translation with torsion	Torsion
2	X-translation	X-translation with torsion	Y-translation	Y-translation	Y-translation with torsion	X-translation
3	Torsion	Torsion	Torsion	X-translation	Torsional	Y-translation
4	Opening-closing	Opening-closing	Opening-closing	Opening-closing	Opening-closing	Dog tail wagging
5	Mixed	Dog tail wagging	Mixed	Mixed	Dog tail wagging	Opening-closing
6	Mixed	Mixed	2 nd X-translation	Mixed	Mixed	Mixed

Note:
Diagonal translation, torsion, opening-closing, and dog-tail-wagging are not acceptable as initial modes of oscillation in buildings

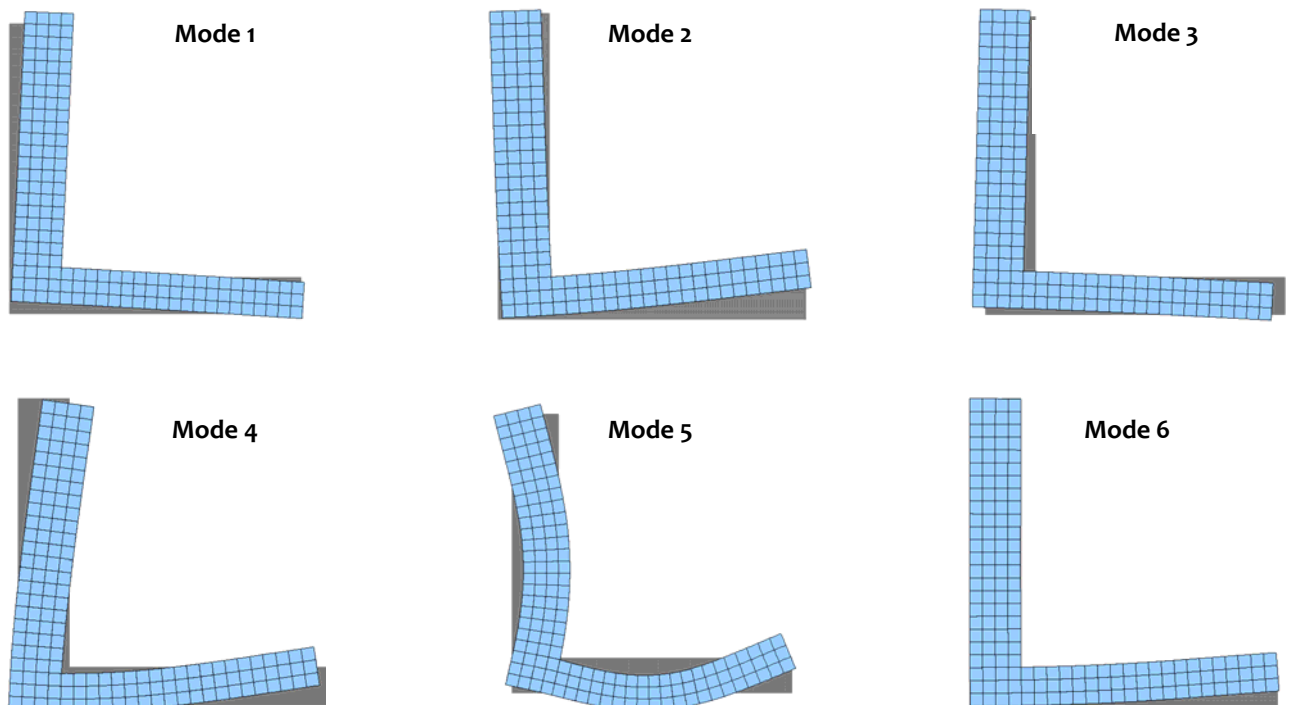


Figure 3.5: Modes of oscillation: First six modes of oscillation in building with L-plan shape

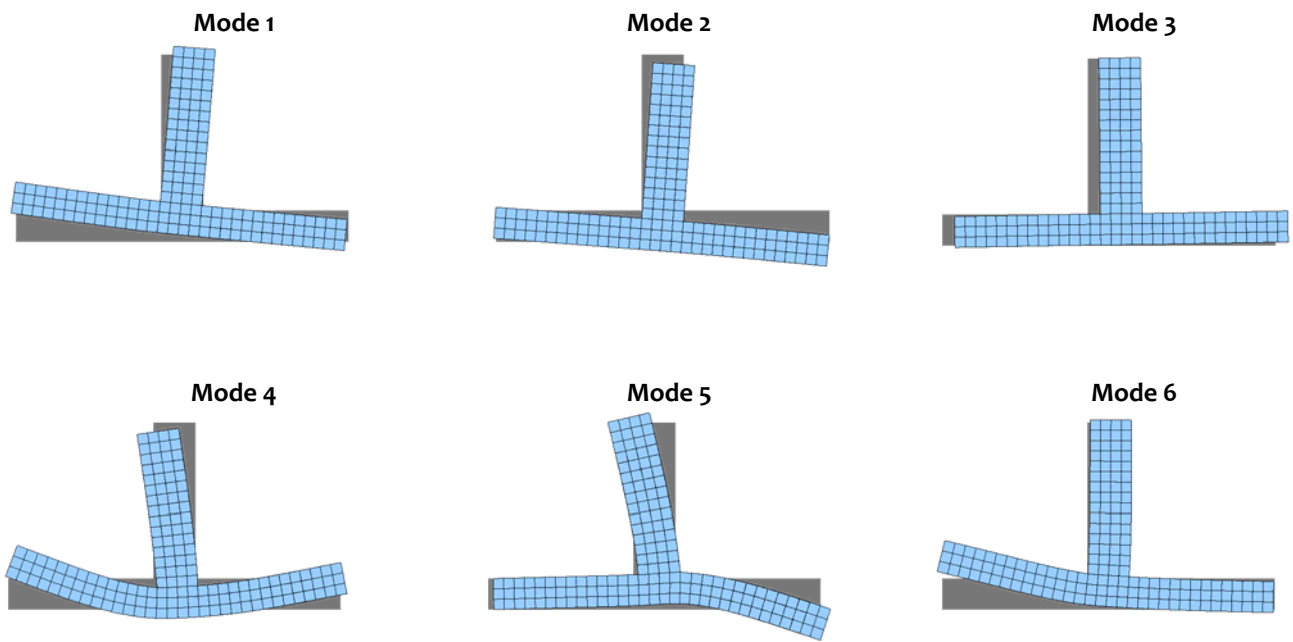


Figure 3.6: Modes of oscillation: First six modes of oscillation in building with T-plan shape

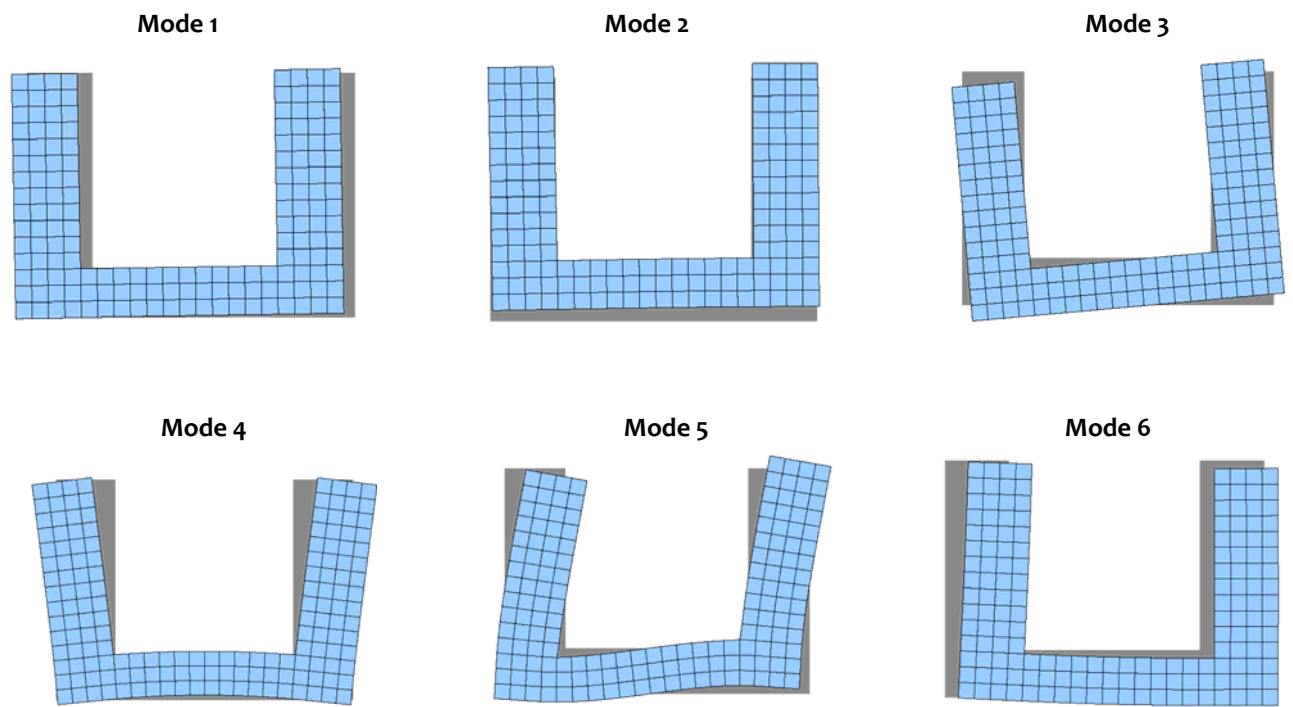


Figure 3.7: Modes of oscillation: First six modes of oscillation in building with U-plan shape

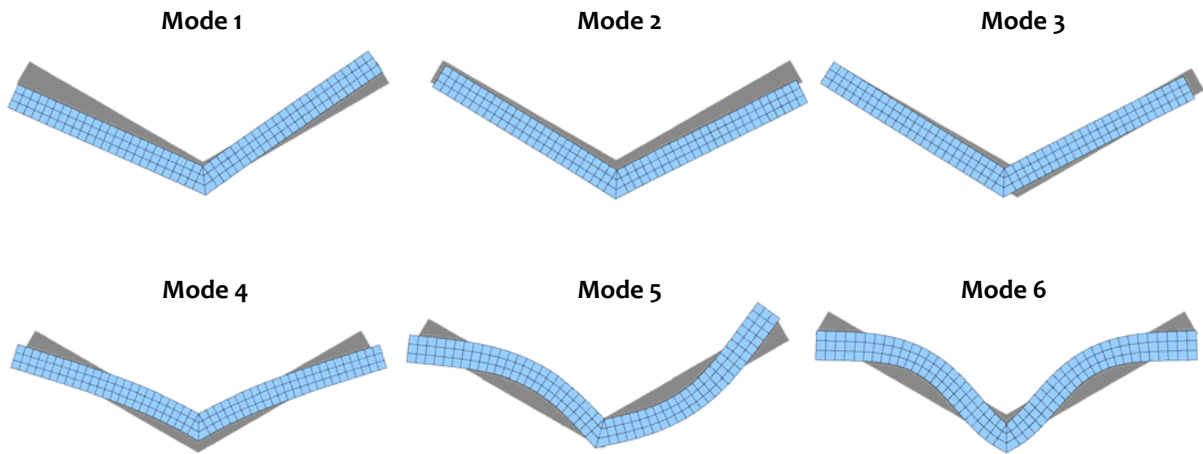


Figure 3.8: *Modes of oscillation:* First six modes of oscillation in building with V-plan shape

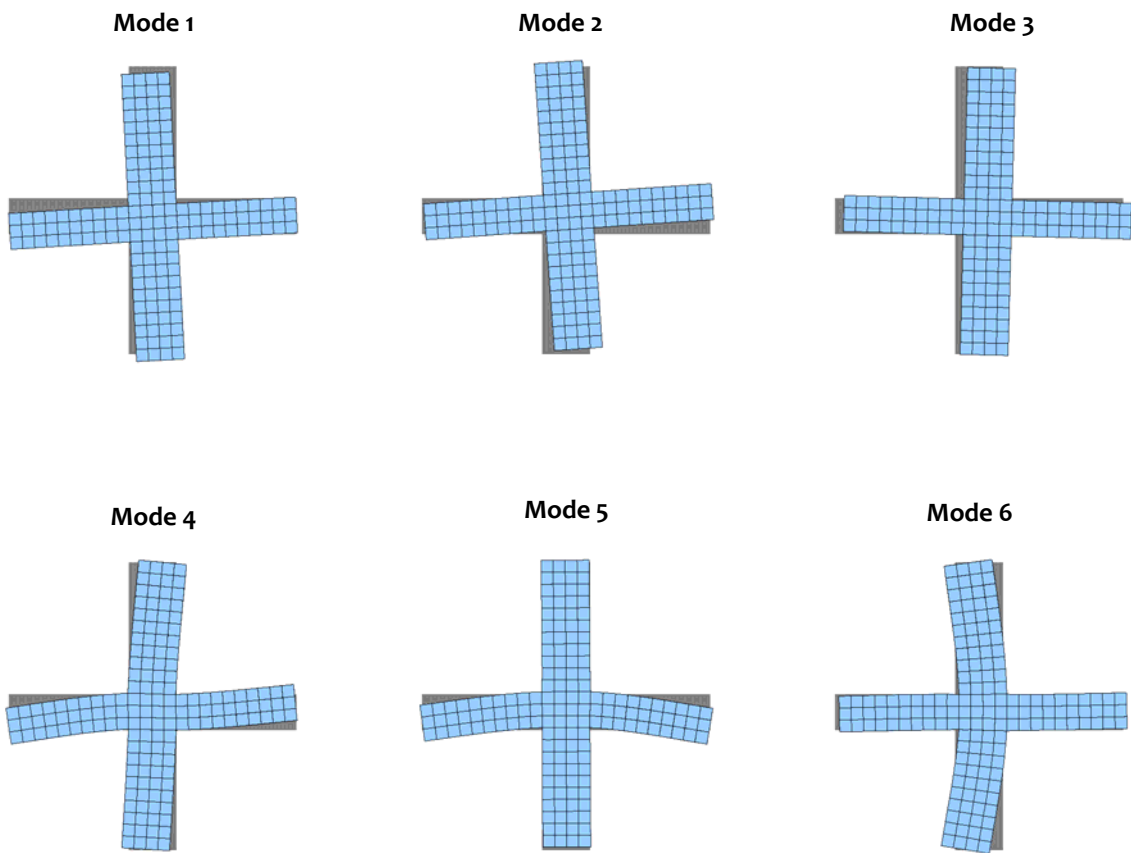


Figure 3.9: *Modes of oscillation:* First six modes of oscillation in building with X-plan shape

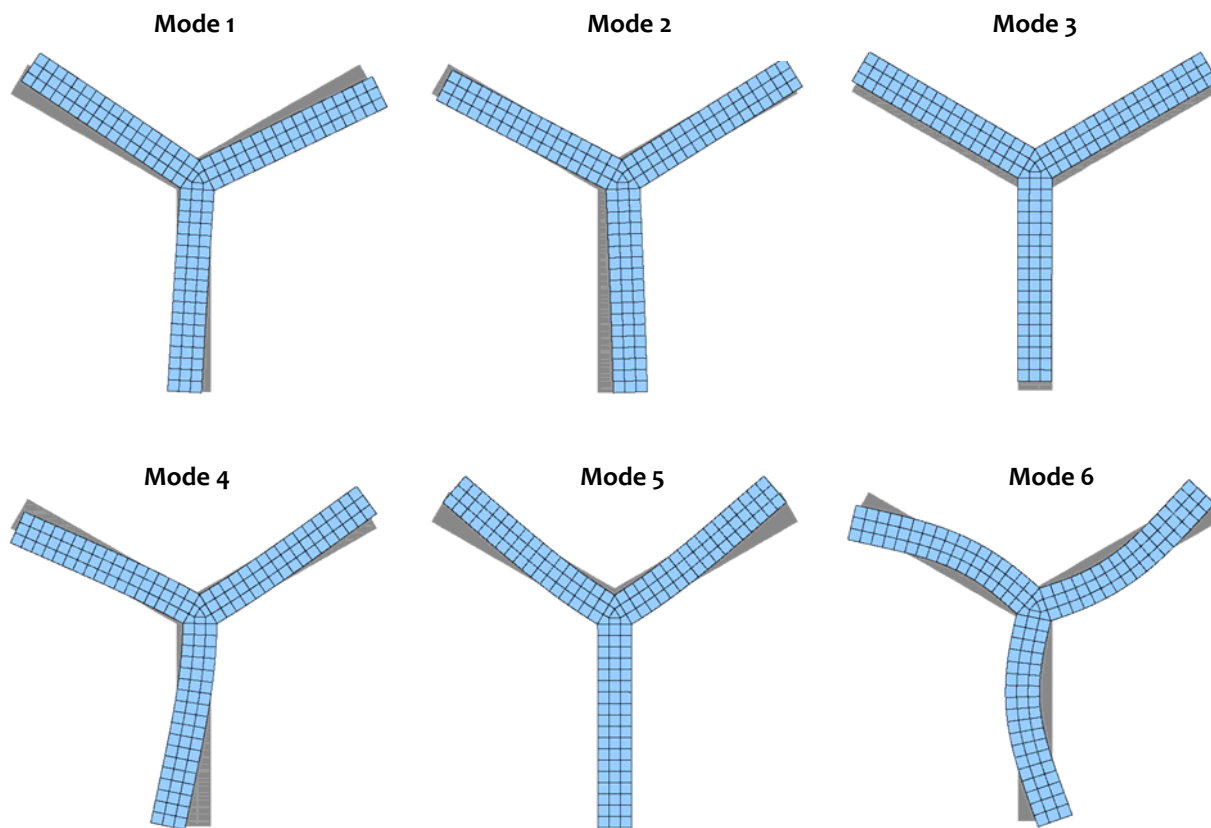


Figure 3.10: *Modes of oscillation:* First six modes of oscillation in building with Y-plan shape

Buildings with complex shapes, particularly with projections or re-entrant corners, exhibit special modes of oscillation, in addition to translatory (pure or diagonal) or torsional modes. These include an opening-closing mode, and the unique local-high-frequency oscillatory mode like, that of the wagging of a dog's tail. *Dog tail wagging* mode of oscillation is interesting because in this mode, only a slender or long projection oscillates and the remaining part of the building almost remains still, just like the dog's body remains still when its tail wags (Figure 3.11). The effect of these special modes of oscillation is to induce high stress concentration at the re-entrant corners that may cause significant structural damage (Figure 3.12).

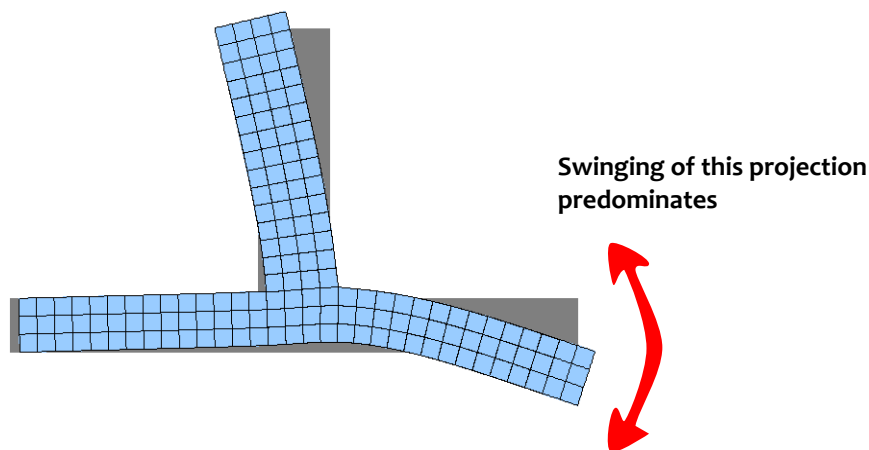
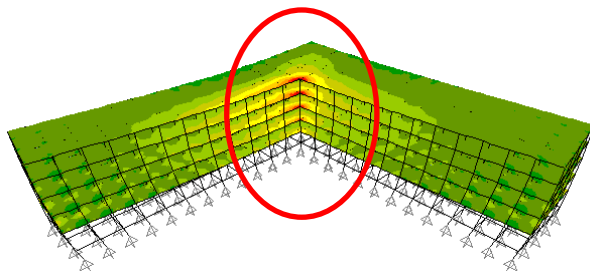
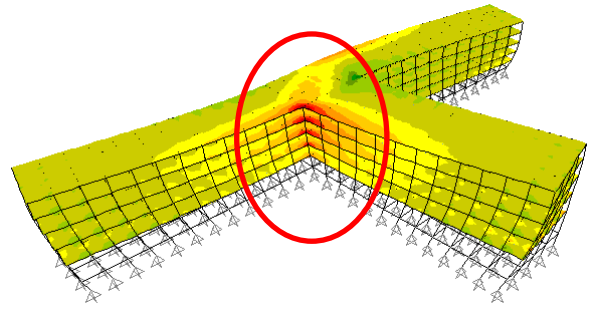


Figure 3.11: *Dog-tail-wagging mode of oscillation:* Only a projection oscillates significantly, while the rest of the building remains almost still



Opening closing mode of oscillation

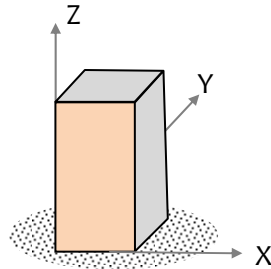


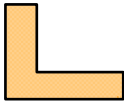
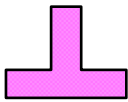
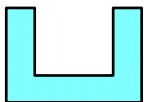
Dog-tail wagging mode of oscillation

Figure 3.12: *Stress concentration at re-entrant corners:* Stress concentration at re-entrant corners in buildings with complex shapes can cause significant damage during earthquake shaking

Animation Set 302

Three-dimensional mode shapes of buildings Complex Plan Shapes



<p><i>L-plan Shape</i></p> 	<p><i>T-plan shape</i></p> 	<p><i>U-plan shape</i></p> 
<p>First Mode <u>Translational in Y-direction</u></p>	<p>First Mode <u>Translational in Y-direction with Torsion</u></p>	<p>First Mode <u>Translational in X-direction</u></p>
<p>Second Mode <u>Translational in X-direction</u></p>	<p>Second Mode <u>Translational in X-direction with Torsion</u></p>	<p>Second Mode <u>Transnational in Y-direction</u></p>
<p>Third Mode <u>Torsional Mode about Z-axis</u></p>	<p>Third Mode <u>Torsional Mode about Z-axis</u></p>	<p>Third Mode <u>Torsional Mode about Z-axis</u></p>
<p>Fourth Mode <u>Opening-closing</u></p>	<p>Fourth Mode <u>Opening-closing</u></p>	<p>Fourth Mode <u>Opening-closing</u></p>
<p>Fifth Mode <u>Torsional Mode with Flexibility of Floor Diaphragm</u></p>	<p>Fifth Mode <u>Dog Tail Wagging</u></p>	<p>Fifth Mode <u>Mixed</u></p>
<p>Sixth Mode <u>Mixed</u></p>	<p>Sixth Mode <u>Mixed</u></p>	<p>Sixth Mode <u>2nd Translational in X-direction</u></p>

Click on the 18 items above to see the animation of the mode shapes
Best when viewed using Windows Media Player

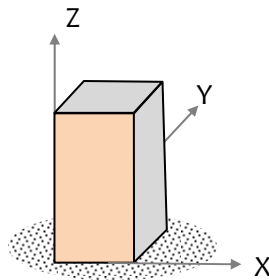
Note:



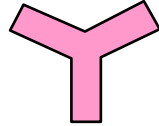
Torsion, opening-closing, and dog-tail-wagging are not acceptable as initial modes of oscillation in buildings

Animation Set 302 continued...

Three-dimensional mode shapes of buildings

Complex Plan Shapes



V-plan Shape	X-plan shape	Y-plan shape
		
First Mode <u>Torsional Mode about Z-axis</u>	First Mode <u>Translational in X-direction with Torsion</u>	First Mode <u>Torsional Mode about Z-axis</u>
Second Mode <u>Translational in Y-direction</u>	Second Mode <u>Translational in Y-direction with Torsion</u>	Second Mode <u>Translational in X-direction</u>
Third Mode <u>Translational in X-direction</u>	Third Mode <u>Torsional Mode about Z-axis</u>	Third Mode <u>Translational in Y-direction</u>
Fourth Mode <u>Opening-closing</u>	Fourth Mode <u>Opening-closing</u>	Fourth Mode <u>Dog Tail Wagging</u>
Fifth Mode <u>Mixed</u>	Fifth Mode <u>Dog Tail Wagging</u>	Fifth Mode <u>Opening-closing</u>
Sixth Mode <u>Mixed</u>	Sixth Mode <u>Mixed</u>	Sixth Mode <u>Mixed</u>

Click on the 18 items above to see the animation of the mode shapes
Best when viewed using Windows Media Player

Note:

Torsion, opening-closing, and dog-tail-wagging are not acceptable as initial modes of oscillation in buildings

(2) Buildings with different projections, but same Plan Shape

Long projections are not good! Projections, if required, must be short, although they still offer stress concentration at their re-entrant corners. Consider buildings with U-plan shape, but with different length of projections (Figure 3.13). The first three modes of oscillation in all the three buildings are same - two lateral translations and torsion, with similar natural periods (between 0.92s to 0.89s). However, the periods of oscillation of the fourth mode, that of opening-closing one, are significantly different - 0.77s, 0.63s, and 0.42s in the buildings with 48m, 32m and 16m projections, respectively. This signifies that the contribution of the opening-closing mode of oscillation in the overall response of the building with 16m projecting arms is least and will ensure better seismic behaviour of the building than buildings with 32m and 48m projecting arms. The first ten modes of these buildings are listed in Table 3.2 along with corresponding natural periods.

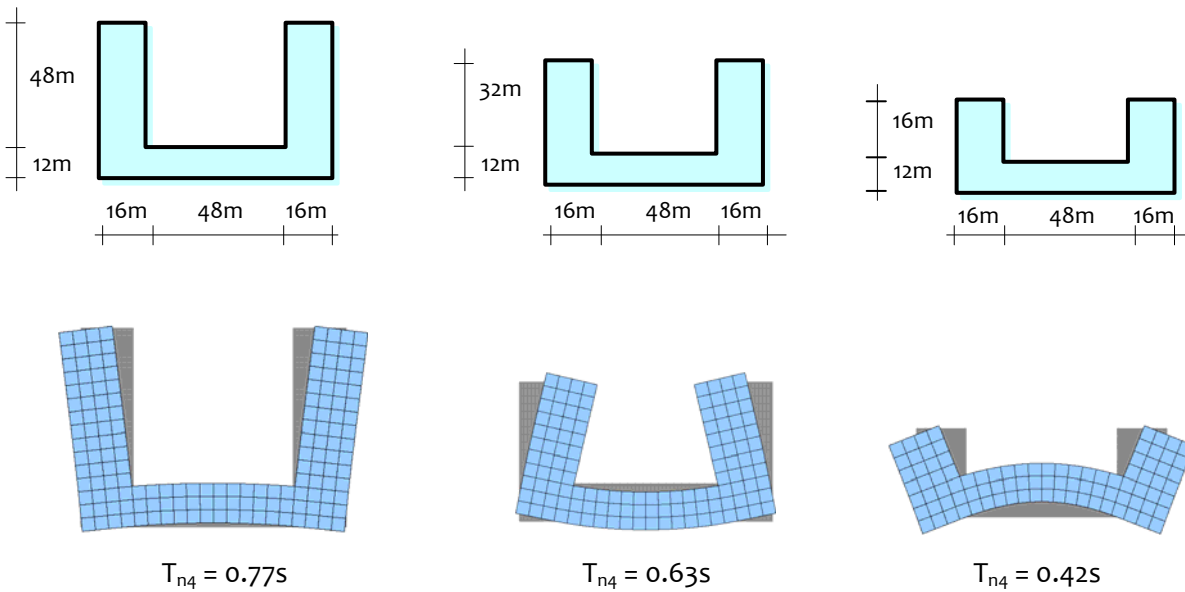
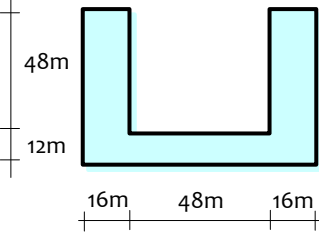
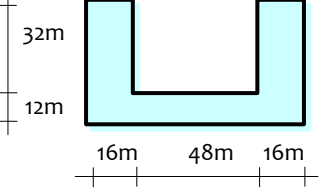
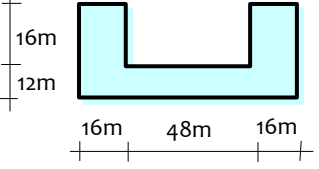


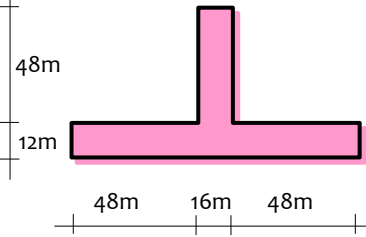
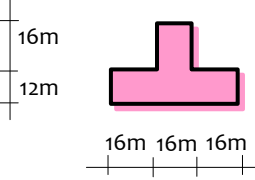
Figure 3.13: Effect of projections: The contribution of opening-closing modes of oscillation to overall response is least in building with smallest projection

Table 3.2: Modes of oscillation in buildings with U-plan shape: Pure translational modes of oscillation are predominant in buildings with small projecting arms

Mode	Type of oscillation in first ten modes in buildings with U-plan shape and different lengths of projecting arm		
			
1	X translation (0.92s)	Y translation (0.92s)	Y translation (0.94s)
2	Y translation (0.91s)	X translation (0.92s)	X translation (0.91s)
3	Torsional (0.89s)	Torsional (0.89s)	Torsional (0.90s)
4	Opening-closing (0.77s)	Opening-closing (0.63s)	Opening-closing (0.42s)
5	Opening-closing (0.48s)	Opening-closing (0.34s)	2 nd Y translation (0.29s)
6	2 nd X translation (0.28s)	2 nd Y translation (0.29s)	2 nd X translation (0.28s)
7	2 nd Y translation (0.28s)	2 nd X translation (0.28s)	2 nd torsion (0.26s)
8	Opening-closing (0.27s)	2 nd torsion (0.26s)	Opening-closing (0.25s)
9	2 nd torsion (0.27s)	Opening-closing (0.26s)	Opening-closing (0.19s)
10	Opening-closing (0.25s)	Opening-closing (0.23s)	Opening-closing (0.17s)

The effect of length of projection on opening-closing mode of oscillation is more pronounced in buildings with T-plan shape. Consider two T-plan shape buildings with the different lengths of projections (Table 3.3). The first ten modes of these two buildings are listed in Table 3.3 along with corresponding natural periods. The natural period of opening-closing mode of oscillation of the building with smaller projection is small as it is one of the higher modes. But, in both buildings, torsional mode is one amongst the first three modes of oscillation, because both the buildings have complex plan shapes (T).

Table 3.3: Modes of oscillation in buildings with T-plan shape: Pure translational modes of oscillation are predominant in buildings with small projecting arms

Mode	Type of oscillation in first ten modes in buildings with T-plan shape and different lengths of projecting arm	
		
1	Y translation (0.92s)	Y translation (0.91s)
2	Torsional (0.92s)	X translation (0.89s)
3	X translation (0.90s)	Torsional (0.87s)
4	Opening-closing (0.49s)	2 nd Y translation (0.28s)
5	Opening-closing (0.48s)	2 nd X translation (0.27s)
6	2 nd Y translation (0.26s)	2 nd torsion (0.27s)
7	2 nd Torsional (0.26s)	3 rd Y translation (0.15s)
8	2 nd X translation (0.25s)	3 rd X translation (0.15s)
9	2 nd opening-closing (0.24s)	3 rd torsion (0.14s)
10	2 nd opening-closing (0.23s)	Opening-closing (0.11s)

In buildings with L-plan shape, the effect of two undesirable mode of oscillations, namely, diagonal translation and opening-closing modes can be avoided by having small projections, which dominate in buildings with large projections. This is seen from results of two buildings with L-plan shape (Table 3.4). Also, the diagonal translation mode is not seen in the building with small projecting arms, but the torsional mode is seen too early in the second and third mode shapes, which is undesirable.

Similarly, in buildings with V-plan shape, Y-plan shape and X-plan shape, the effect of two undesirable modes of oscillation, namely opening-closing and dog-tail-wagging modes can be avoided by having small projections. This is illustrated through results of buildings with V-plan shape (Table 3.5), Y-plan shape (Table 3.6), and buildings with X-plan shape (Table 3.7). Both opening-closing and dog-tail-wagging modes are not seen in the buildings with small projections. But, again, due to the complex shape, torsional mode of oscillation is present in all buildings. And, torsion is the fundamental mode of oscillation in building with Y-plan shape and especially that with large projections. The mode shape and associated stress contour of the 2nd torsional mode of oscillation in the building with Y-plan shape and large (48m) projections are shown in Figure 3.14. In buildings with X-plan shape and long projections, dog-tail-wagging mode causes large stress concentration at the re-entrant corners (Figure 3.15).

Table 3.4: Modes of oscillation in buildings with L-plan shape: Pure translational modes of oscillation are predominant in buildings with small projecting arms

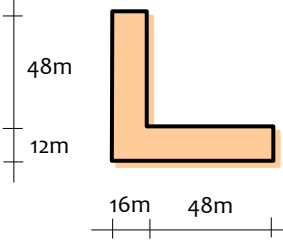
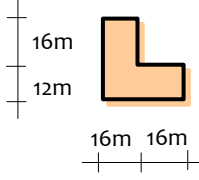
Mode	Type of oscillation in first ten modes in buildings with L-plan shape and different lengths of projecting arm	
		
1	Diagonal translation (0.92s)	Y translation (0.91s)
2	Diagonal translation (0.91s)	X translation (0.90s)
3	Torsional (0.88s)	Torsional (0.85s)
4	Opening-closing (0.47s)	2 nd Y translation (0.28s)
5	2 nd diagonal translation (0.28s)	2 nd X translation (0.28s)
6	2 nd diagonal translation (0.27s)	2 nd torsion (0.26s)
7	2 nd torsion (0.27s)	3 rd Y translation (0.15s)
8	2 nd opening-closing (0.25s)	3 rd X translation (0.15s)
9	Mixed (0.16s)	3 rd torsional (0.14s)
10	3 rd diagonal translation (0.15s)	Opening-closing (0.10s)

Table 3.5: Modes of oscillation in buildings with V-plan shape: Pure translational modes of oscillation are predominant in buildings with small projecting arms

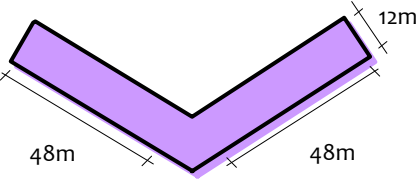
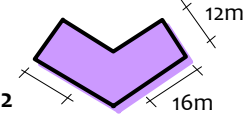
Mode	Type of oscillation in first ten modes in buildings with V-plan shape and different lengths of projecting arm	
		
1	Y translation (0.87s)	Y translation (0.86s)
2	X translation (0.87s)	X translation (0.85s)
3	Torsional (0.81s)	Torsional (0.78s)
4	Opening-closing (0.43s)	2 nd Y translation (0.27s)
5	2 nd Y translation (0.27s)	2 nd X translation (0.27s)
6	2 nd X translation (0.27s)	2 nd torsion (0.26s)
7	2 nd torsion (0.26s)	3 rd Y translation (0.15s)
8	Opening-closing (0.24s)	3 rd X translation (0.15s)
9	Mixed (0.16s)	3 rd torsional (0.14s)
10	Mixed (0.15s)	4 th Y translation (0.10s)

Table 3.6: Modes of oscillation in buildings with Y-plan shape: Pure translational modes of oscillation are predominant in buildings with small projecting arms

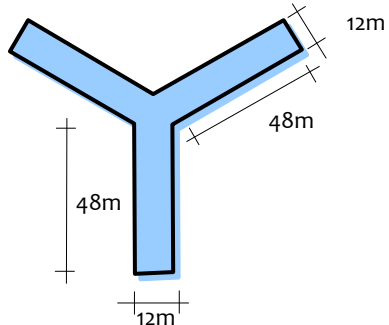
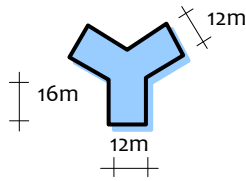
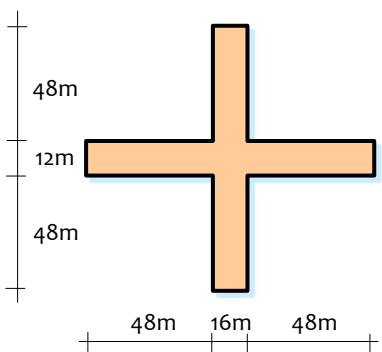
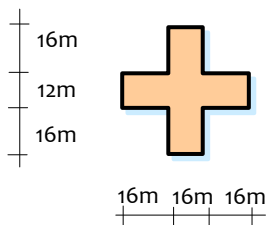
Mode	Type of oscillation in first ten modes in buildings with Y-plan shape and different lengths of projecting arm	
		
1	Torsional (0.87s)	Y translation (0.87s)
2	Y translation (0.85s)	X translation (0.85s)
3	X translation (0.84s)	Torsional (0.81s)
4	Opening-closing (0.47s)	2 nd Y translation (0.26s)
5	Dog Tail wagging (0.47s)	2 nd X translation (0.26s)
6	2 nd torsional (0.27s)	2 nd torsion (0.26s)
7	2 nd Y translation (0.27s)	3 rd Y translation (0.16s)
8	2 nd X translation (0.27s)	3 rd X translation (0.15s)
9	2 nd dog tail wagging (0.24s)	3 rd torsional (0.14s)
10	2 nd opening-closing (0.24s)	4 th Y translation (0.10s)

Table 3.7: Modes of oscillation in buildings with X-plan shape: Pure translational modes of oscillation are predominant in buildings with small projecting arms

Mode	Type of oscillation in first ten modes in buildings with X-plan shape and different lengths of projecting arm	
		
1	X translation (0.89s)	Y translation (0.83s)
2	Y translation (0.85s)	X translation (0.82s)
3	Torsional (0.75s)	Torsional (0.81s)
4	Dog tail wagging (0.49s)	2 nd Y translation (0.26s)
5	2 nd Dog Tail wagging (0.40s)	2 nd X translation (0.26s)
6	Opening-closing (0.37s)	2 nd torsion (0.26s)
7	2 nd torsional (0.28s)	3 rd Y translation (0.16s)
8	2 nd X translation (0.27s)	3 rd X translation (0.15s)
9	2 nd Y translation (0.26s)	3 rd torsional (0.14s)
10	3 rd torsion (0.24s)	4 th Y translation (0.10s)

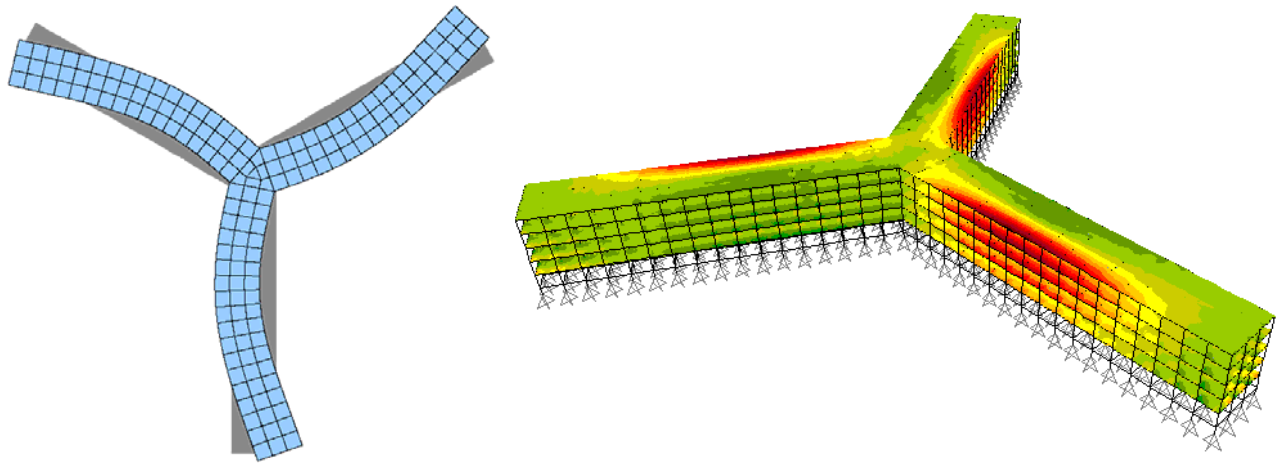


Figure 3.14: *Torsional mode of oscillation:* Torsional mode of oscillation in buildings with complex shape contribute significantly to overall building response if it has large natural period

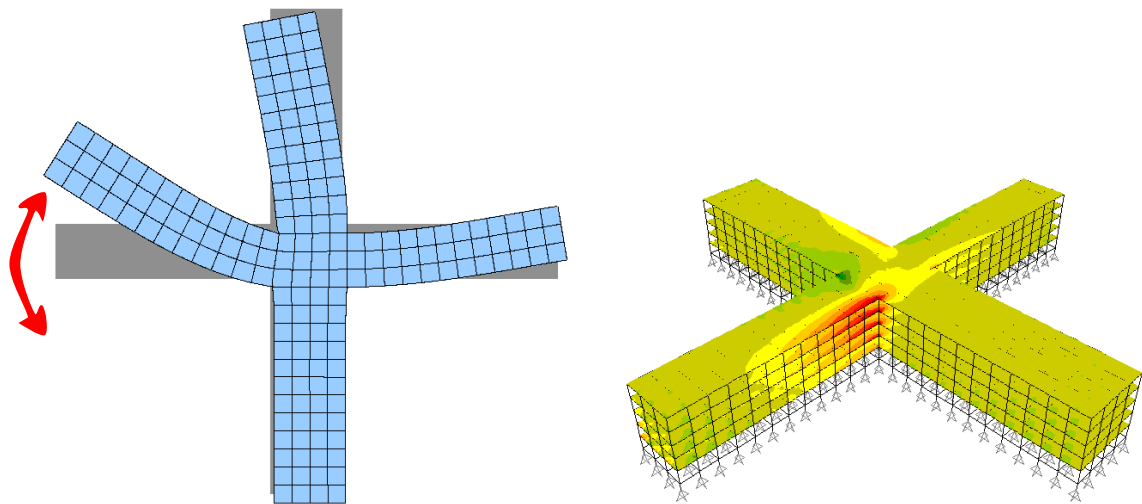


Figure 3.15: *Dog-tail-wagging mode of oscillation:* Dog-tail-wagging mode of oscillation in building with X-plan shape cause significant stress concentration at re-entrant corners

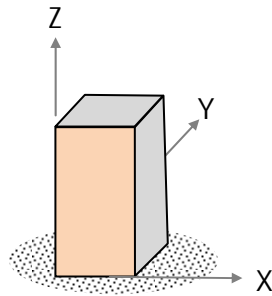
In summary, the important observations are

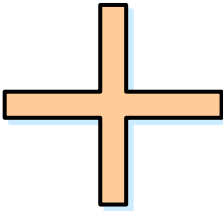
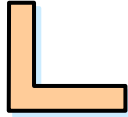
- (1) Torsional modes of oscillations are predominant in buildings with L-, X- and Y-plan shapes, which should be avoided with suitable choice of structural configuration;
- (2) Diagonal translation modes of oscillations are predominant in buildings with L- and X-plan shapes, which should be avoided with suitable changes in structural configuration;
- (3) Opening-closing and dog-tail-wagging modes of oscillation are predominant in buildings with large projecting arms;
- (4) Opening-closing and dog-tail-wagging modes of oscillation cause significant stress concentrations at re-entrant corners and can cause structural damage; and
- (5) It is prudent to not use buildings with complex plan shapes, or if compelled, ensure that their natural periods are small (outside the range of natural periods with significant earthquake energy).

Also, the fundamental periods of oscillation of all buildings in the above examples are nearly the same (about 0.9s). This is because the mass to stiffness ratio per unit area is same in all buildings, because they are made of the same 12m×16m building modules (Figure 3.2).

Animation Set 303

Special modes of oscillation of buildings with complex plan shapes
Stress concentration at re-entrant corners



<p>X-plan Shape</p> 	<p>L-plan shape</p> 
<p>Dog Tail Wagging Mode</p>	<p>Opening-closing Mode</p>
<p>Click on the 2 items above to see the animation of stress concentration at re-entrant corners Best when viewed using Windows Media Player</p>	
<p>Note: Opening-closing, and dog-tail-wagging are not acceptable as initial modes of oscillation in buildings</p>	

(b) Plan Aspect Ratio

It is not good to have buildings with large plan aspect ratio, just like it is not good to have buildings with large projections. During earthquake shaking, inertia force is mobilized in the building, usually at the floor levels where the mass is large. The inertia force then is distributed to different lateral load resisting systems (columns and/or structural walls). It is preferred to distribute this lateral inertia force to various lateral load resisting systems in proportion to their lateral load resisting capacities (Figure 3.16). This is achieved when the floor slabs do not deform too much in their own (horizontal) plane. This condition, when floor slab helps in distributing the inertia force to different lateral load resisting systems in proportion to their stiffness, is known as *rigid diaphragm action*. However, the inertia force is distributed based on tributary area when floor slabs deform in their plane. This leads to overloading of members with less capacity and thus causing undue damage to buildings. Floor slabs in buildings with large plan aspect ratio (>4) may not provide rigid diaphragm action.

Consider six five-storey buildings with 3 bays of 4m each along the Y-direction, and increasing number of bays (3, 6, 12, 16, 24, and 30) each of the same 4m along the X-direction. Thus, the six buildings have plan aspect ratios of 1, 2, 4, 6, 8, and 10. These six buildings are designed for gravity loads and lateral load of 10% of the building weight, and have 250mm thick reinforced concrete structural walls at the two ends while regular 400×400 columns are present at every 4m grid. It is seen that the maximum displacement at the middle of the diaphragm increases with increase in plan aspect ratio (Figure 3.17). Some design codes (e.g., IS 1893 (Part 1)) prefer to restrict maximum lateral in plane displacement of diaphragm at any point to within 1.5 times the average displacements of the entire diaphragm for good seismic performance of buildings. This is achieved in buildings with plan aspect ratio of up to 4 (Figure 3.18). The in-plane flexibility of the floor diaphragm in building with aspect ratio of 10 is shown in Figure 3.19. This in-plane floor flexibility is not observed if the structural walls are absent in the end bays. Thus, designers have to examine the choice of location of structural walls adopted.

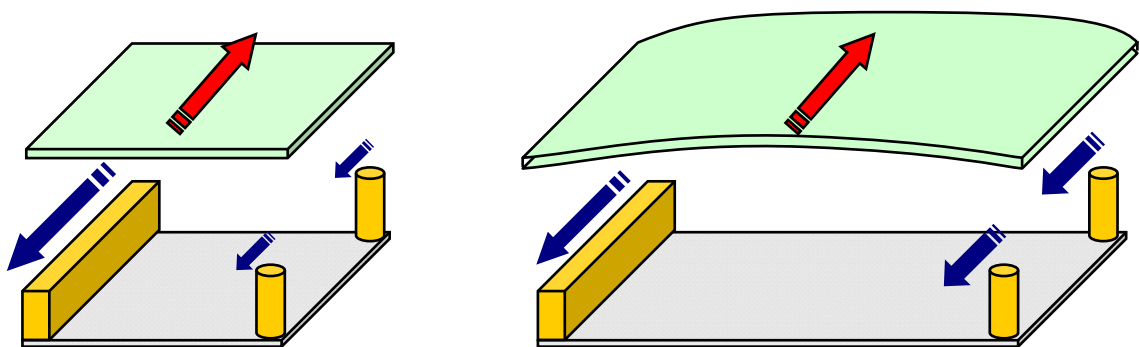


Figure 3.16: *Rigid diaphragm action:* In-plane flexural bending of floor slabs affects the distribution of mobilized lateral inertia force to different lateral force resisting members

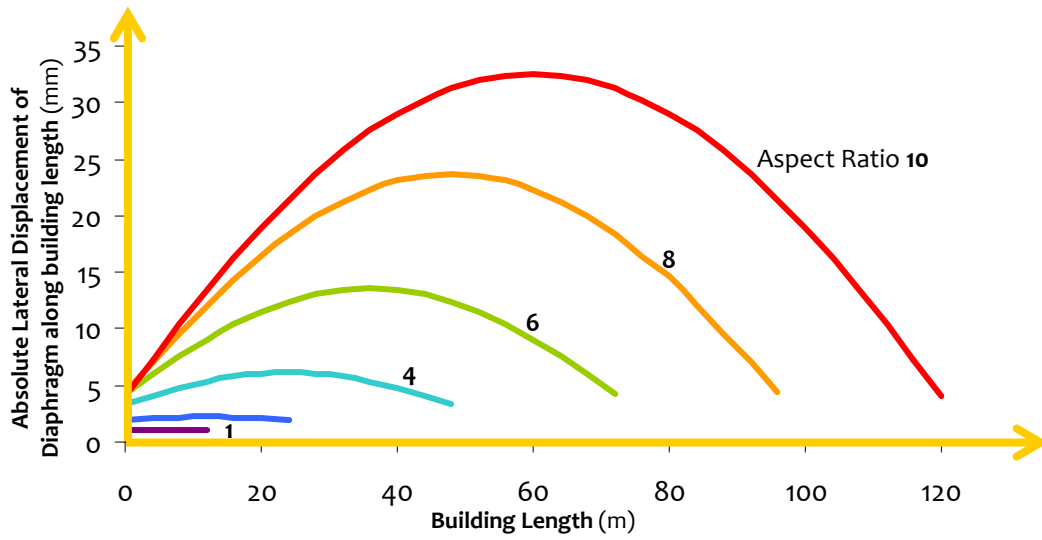


Figure 3.17: Diaphragm action: In-plane deformation increases with increase in-plan aspect ratio

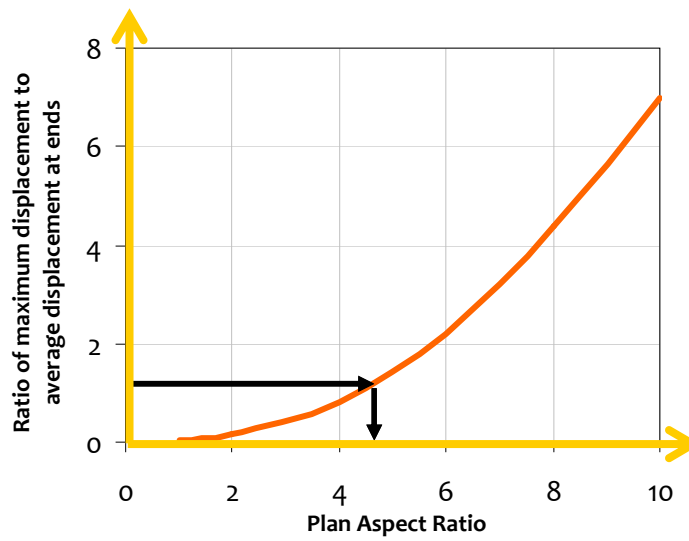


Figure 3.18: Diaphragm action: Almost rigid diaphragm action is realized in buildings with plan aspect ratio of 4 or less

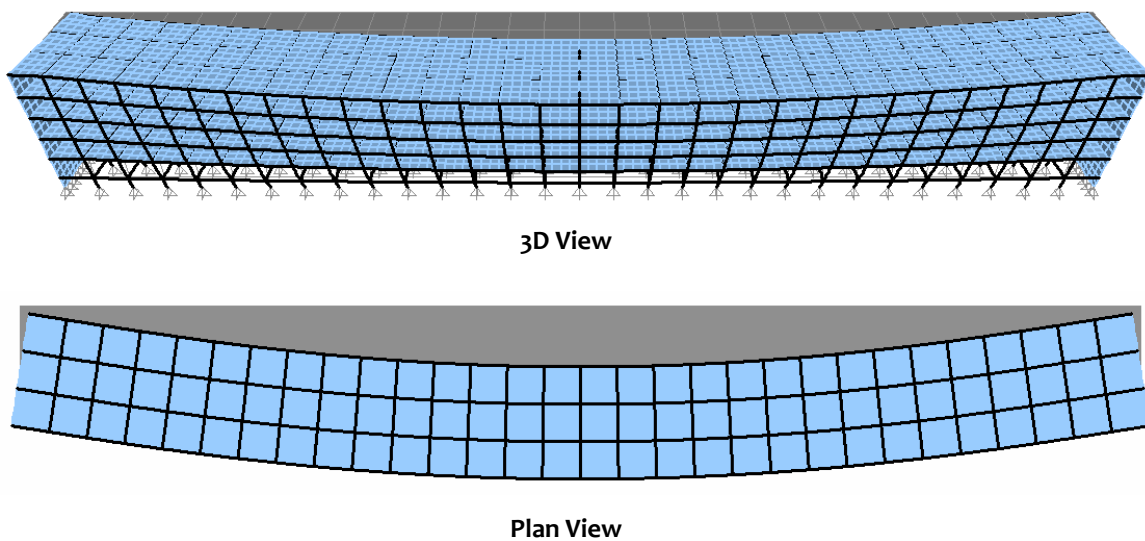
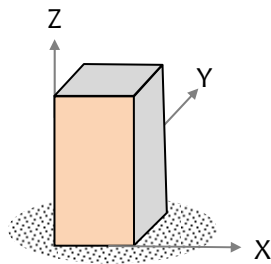


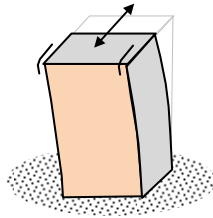
Figure 3.19: Diaphragm action: Flexible diaphragm action in buildings with large plan aspect ratio

Animation Set 304

Three-dimensional mode shapes of buildings **Effect of Plan Aspect Ratio**



Fundamental Translation in Y-direction



Plan Aspect Ratio of 1

First translational mode in Y-direction

Plan Aspect Ratio of 2

First translational mode in Y-direction

Plan Aspect Ratio of 4

First translational mode in Y-direction

Plan Aspect Ratio of 6

First translational mode in Y-direction

Plan Aspect Ratio of 8

First translational mode in Y-direction

Plan Aspect Ratio of 10

First translational mode in Y-direction

Click on the 6 items above to see the animation of the mode shapes

Best when viewed using Windows Media Player

(1) *Buildings with distributed lateral load resisting systems in plan and cut-outs*

In-plane deformation of slab depends on (a) distribution in plan of lateral stiffness of vertical elements of the lateral load resisting system, and (b) distribution in plan of mass of building at that floor level. In-plane lateral deformation is studied of 5-storey buildings with 3 bays along Y-direction and 30 bays along X-direction with different lateral load resisting elements in plan; see buildings A1, A2, A3, A4 and A5 in Figure 3.20a. Bay length, storey height and cross-section sizes of beams and columns are same as that of the benchmark building. RC structural walls are used to increase the lateral resistance at different locations in plan of the building. The total area of the walls is kept the same, and the same total area is distributed along the length of the building. Building with structural wall placed ONLY at the ends shows a major increase in in-plane deformation in the floor diaphragm of the building (Figure 3.21a). This relative deformation decreases when the lateral load resisting elements are distributed more uniformly (at more locations) along the plan length of the building. The use of the third wall at the middle of the building (as in building A3) significantly drops the in-plane deformation in the floor diaphragm, in contrast to that with only two end walls (as in building A2); additional increase in number of walls improves the situation further.

Cut-outs in the floor diaphragm aggravate the situation further in the above buildings, especially in the central area; see buildings B1, B2, B3, B4 and B5 in Figure 3.20b. The in-plane deformation of the floor increases with cut-outs (Figure 3.21b). Further, in-plane flexibility of buildings with cut-outs also decreases with more number of well distributed structural walls along the length of the building, as in buildings with no cut-outs (Figure 3.22).

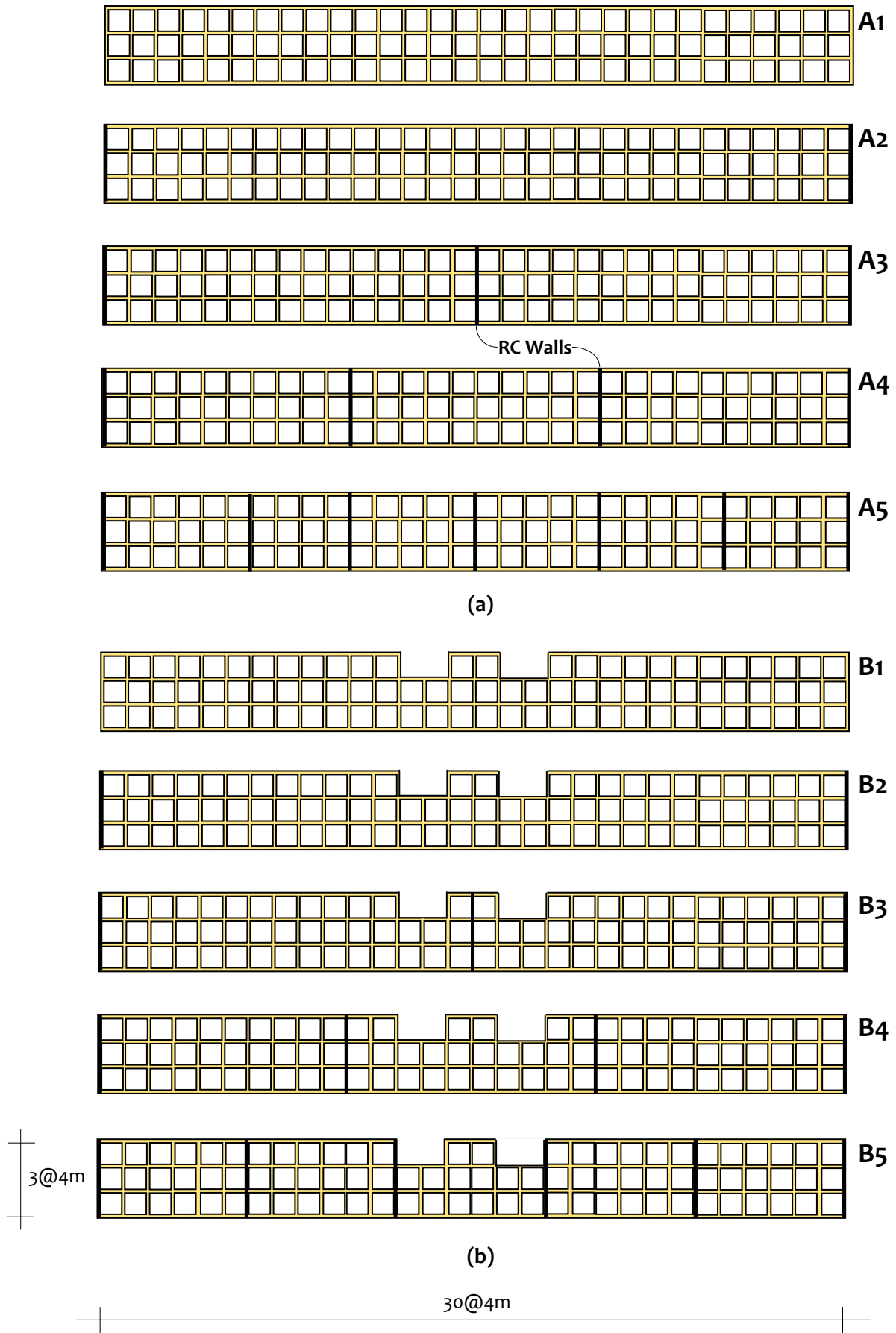


Figure 3.20: Buildings with walls and cut-outs distributed in plan: Plan shapes of buildings considered (a) with NO cut-outs in floor slabs, and (b) with cut-outs in floor slabs

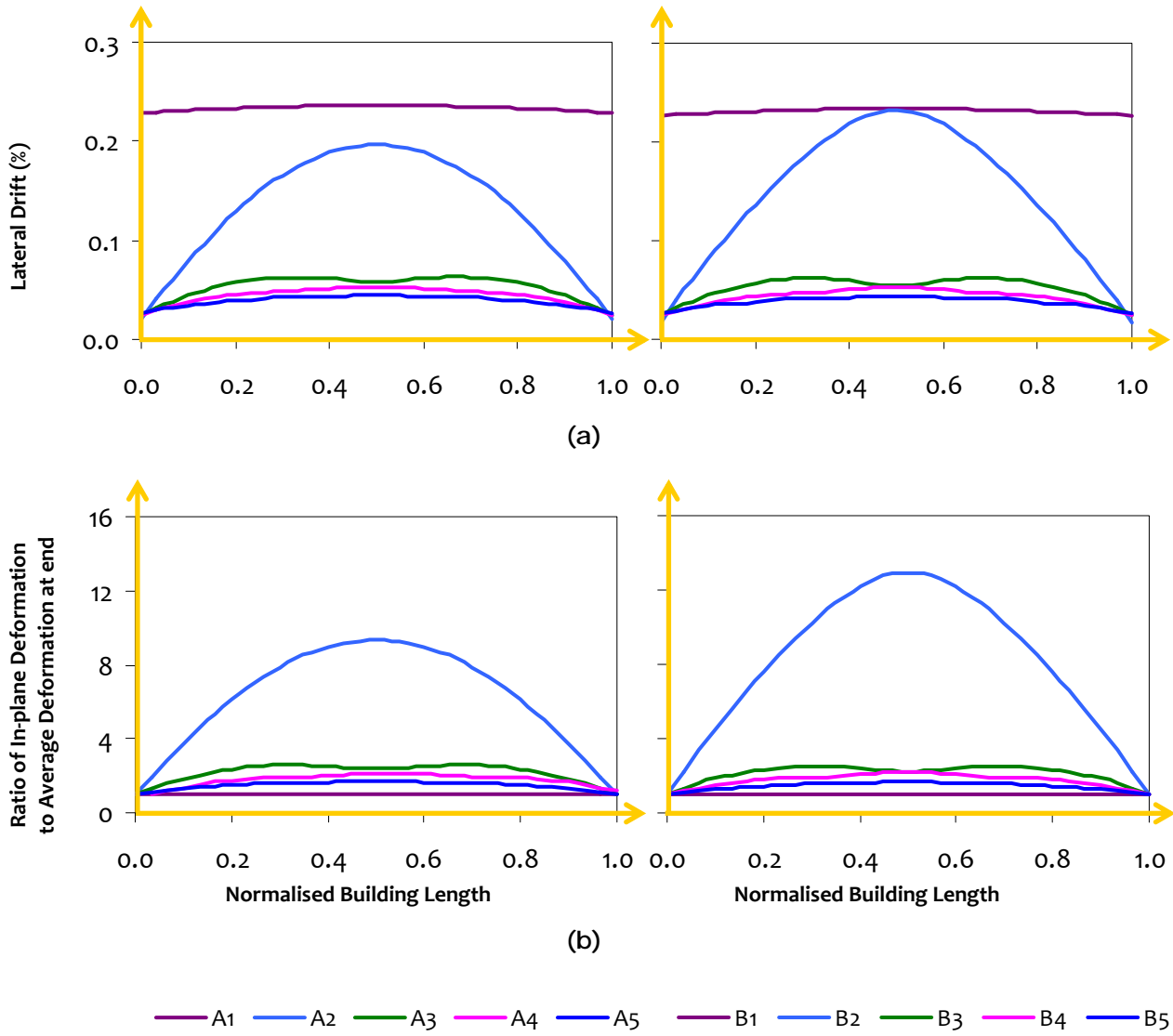


Figure 3.21: Roof diaphragm deformation: Cut-outs increase lateral deformation while well distributed LLRS reduces diaphragm flexibility and controls lateral deformation

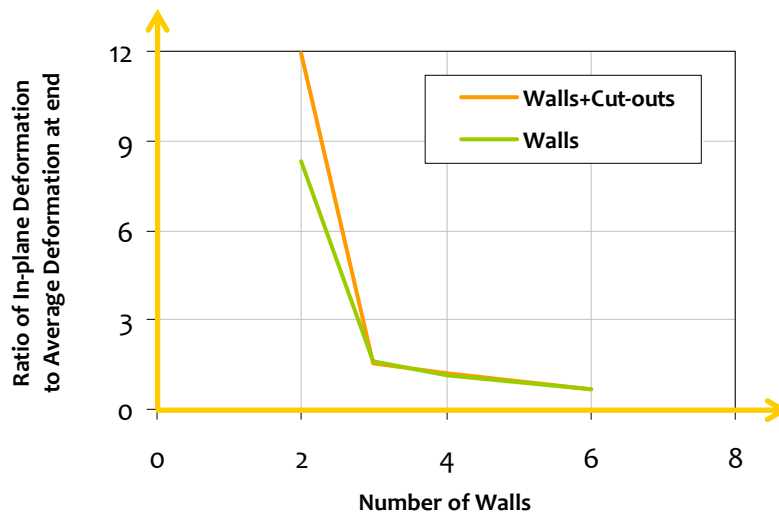
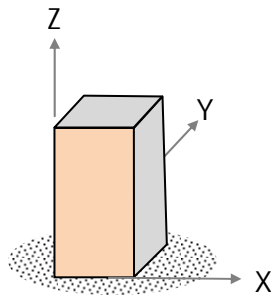


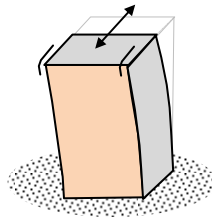
Figure 3.22: Relative deformation within the floor diaphragm at roof level in buildings with NO cut-outs and in buildings with cut-outs in floor slabs

Animation Set 305

Three-dimensional mode shapes of buildings Effect of Distribution of Lateral Load Resisting System



Fundamental Translation in Y-direction



Building with NO Lateral Load Resisting System (Building A1)
First translational mode in Y-direction

Building with Structural Walls at Ends (Building A2)
First translational mode in Y-direction

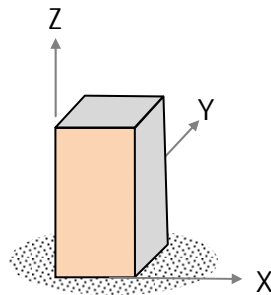
Building with Structural Walls at Ends and Middle (Building A3)
First translational mode in Y-direction

Building with Structural Wall distributed Throughout (Building A5)
First translational mode in Y-direction

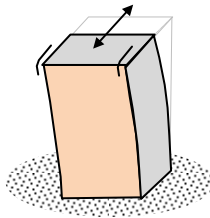
Click on the 4 items above to see the animation of the mode shapes
Best when viewed using Windows Media Player

Animation Set 306

Three-dimensional mode shapes of buildings **Effect of Opening in Slab**



Fundamental Translation in Y-direction



Building with NO Lateral Load Resisting System (Building B1)

First translational mode in Y-direction

Building with Structural Walls at Ends (Building B2)

First translational mode in Y-direction

Building with Structural Walls at Ends and Middle (Building B3)

First translational mode in Y-direction

Building with Structural Wall distributed Throughout (Building B5)

First translational mode in Y-direction

Click on the 4 items above to see the animation of the mode shapes
Best when viewed using Windows Media Player

(2) Buildings with regular plan shape, but of large plan size and with cut-outs

It is not desirable to have a building with large plan size, because lateral load resisting systems are required to be distributed throughout the building plan to carry the inertia force through direct load paths with no/little detours. When these lateral load resisting systems undergo inelastic actions, they are likely to loose stiffness and thereby the building generates stiffness eccentricity, which is detrimental to the symmetrical swinging of the building during earthquake shaking. The problem is even more aggravated if building with large plan has large openings or cut-outs at the center or inside the plan of the building. These large cut-outs in the plan of the building push the floor diaphragms of the building to not remain *rigid* in their own plane, which causes the inertia force mobilized at floor levels during earthquake shaking to be unevenly distributed to the different lateral load resisting elements. This is not desirable for good seismic performance of this type of buildings; this irregularity should be avoided or minimised.

Consider five single-storey buildings with 20 bays (of 4m each) in their two plan directions (X and Y), but with different size of central openings (of 1, 4, 16 and 64% of overall plan area of 6400m²) symmetrically located at the center of the building (Figure 3.23). All buildings are designed for gravity loads and lateral load of 10% of the building weight. The buildings have 250mm thick RC structural walls at their corners in both directions and 400×400mm size columns at every 4m grid point.

The maximum displacement at the middle of the diaphragm increases with increase in area of opening (Figure 3.24). Some design codes (*e.g.*, IS 1893 (Part 1)) prefer to restrict maximum opening to 50% of diaphragm area. This is expected to limit the in-plane flexibility of the diaphragm and ensure in-plane lateral displacement of diaphragm at any point to within 1.5 times the average displacements of the entire diaphragm. Further, the rate of increase of lateral in-plane displacement of diaphragm is small up to opening area of about 25-30% (Figure 3.24), beyond which, it increases rapidly. Also, the actual in-plane displacement at the center of the diaphragm depends on the in-plane stiffness of the structural walls present and can be controlled by suitably designing structural walls in buildings. The results of buildings with 2 and 4 bays long structural walls in each direction at each corner are shown in Figure 3.24.

Further, the ratio of maximum displacement to average displacement at ends of the floor diaphragm with no opening is (0.15-0.45) not negligible even in case of building with no cut-out and plan aspect ratio of unity. This is unlike in the case of similar square building (with 3 bays of 4m each in both X- and Y-directions) discussed earlier (Figure 3.18 and plan aspect ratio of 1); the difference is the plan area (6400m² as against 144m²). The in-plane flexibility of the floor diaphragm in building with 64% opening is shown in Figure 3.25.

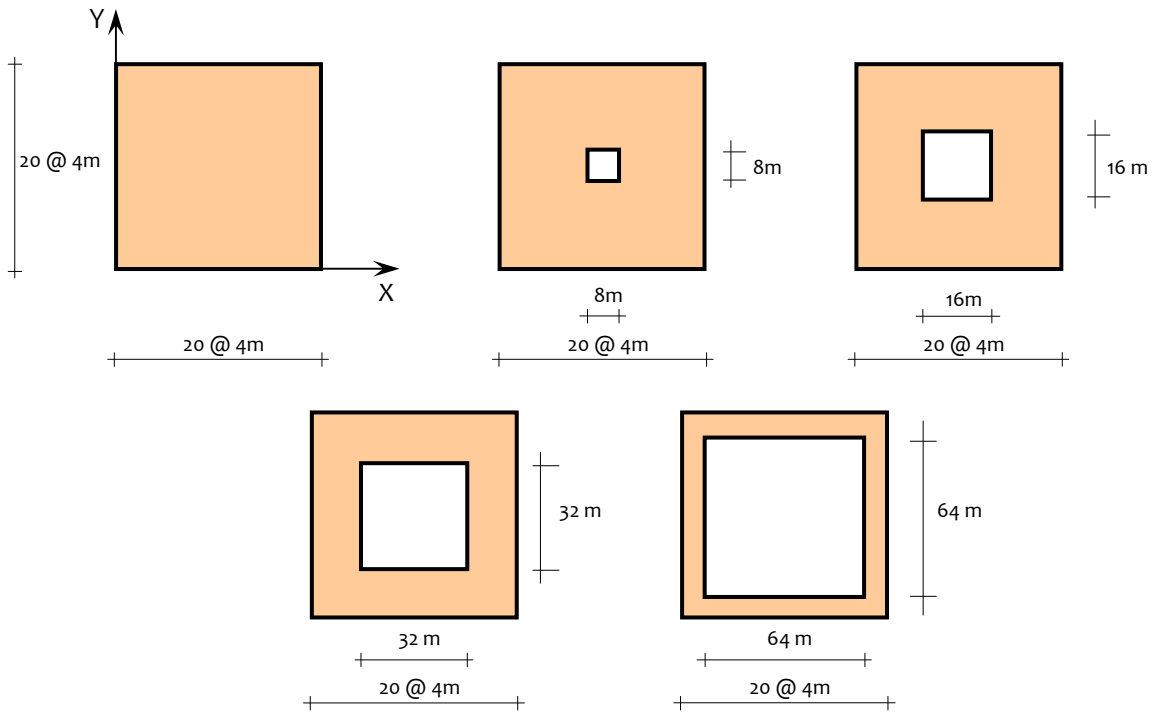


Figure 3.23: Effect of cut-out in diaphragm: different size of openings considered

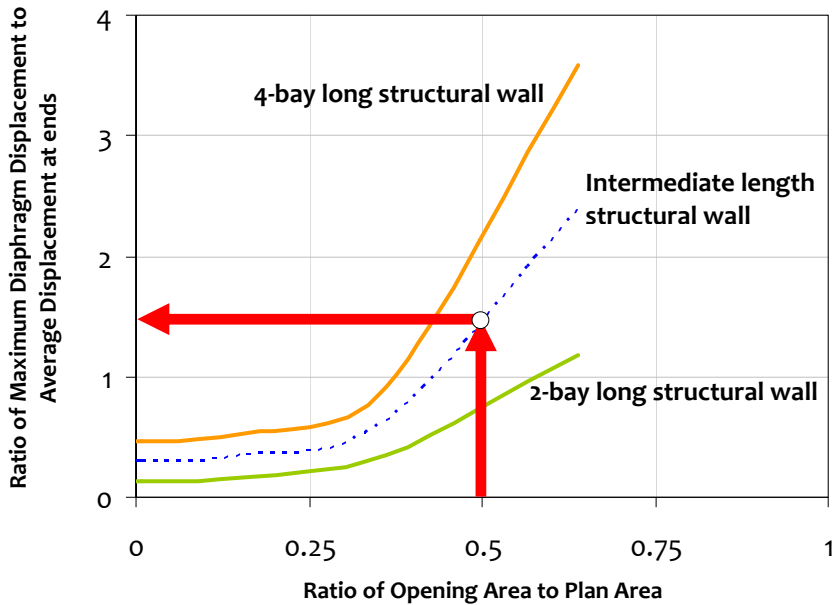


Figure 3.24: Effect of Cut-Outs in Diaphragms: Rigid diaphragm action diminishes with openings areas of more than about 25% (i.e., opening size more than ~50% of the dimension)

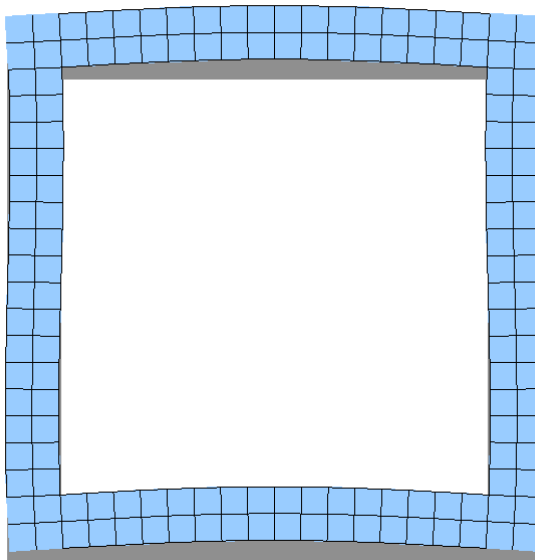


Figure 3.25: *Effect of cut-out in diaphragm:* Rigid diaphragm action is not seen in diaphragm with openings of 50% or more

(c) Slenderness Ratio

It is not desirable to have buildings with large slenderness ratio, just like it is not good to have buildings with large projecting arms and large plan aspect ratio. During earthquake shaking, buildings sway laterally and excessive lateral displacement is not desirable. Large lateral displacements cause significant non-structural damage, structural damage and even second order $P-\Delta$ effects that lead to collapse of buildings. Design codes recommend that inter-storey drift under design earthquake forces be restricted to 0.4 percent of storey height.

Seven moment-resisting frame buildings are considered of the same 3 bays by 4 (12m×16m) plan (Figure 3.2), but of 2, 5, 8, 10, 15, 20 and 25 storeys. The beams and columns are designed for gravity and lateral loads. The column sizes in the buildings are 400×400 in 2 and 5 storey buildings, 600×600 in 8 and 10 storey buildings, and 800×800 in 15, 20 and 25 storey buildings. The variation of roof displacement with respect to slenderness ratio (H/L and H/B) in the two directions is shown in Figure 3.26. Roof displacement increases with increase in slenderness ratio; special lateral load resisting systems (*e.g.*, shear wall, bracings, tubes) should be used to control the drift.

The deformed shape of 5, 15, 20 and 25 storey buildings are shown in Figure 3.27. Also, note the sudden increase in bending moment demand in the first storey beams, particularly in buildings with large slenderness ratio compared to in buildings with smaller slenderness ratio (Figure 3.28). Thus, maximum damage is expected to be confined to the first few storeys in buildings with large slenderness ratio. This is attributed to the Poisson's effect in the lower section of the building (close to the base) where end effects dominate upto a height equal to the base width of the building.

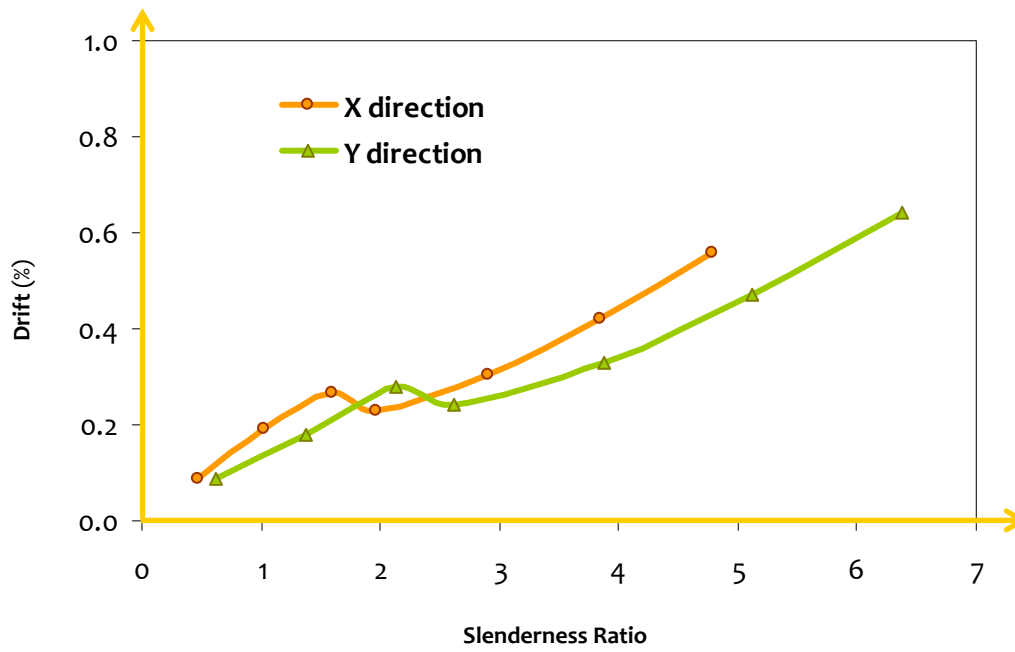


Figure 3.26: *Global drift:* Large lateral drift under design loads is not good

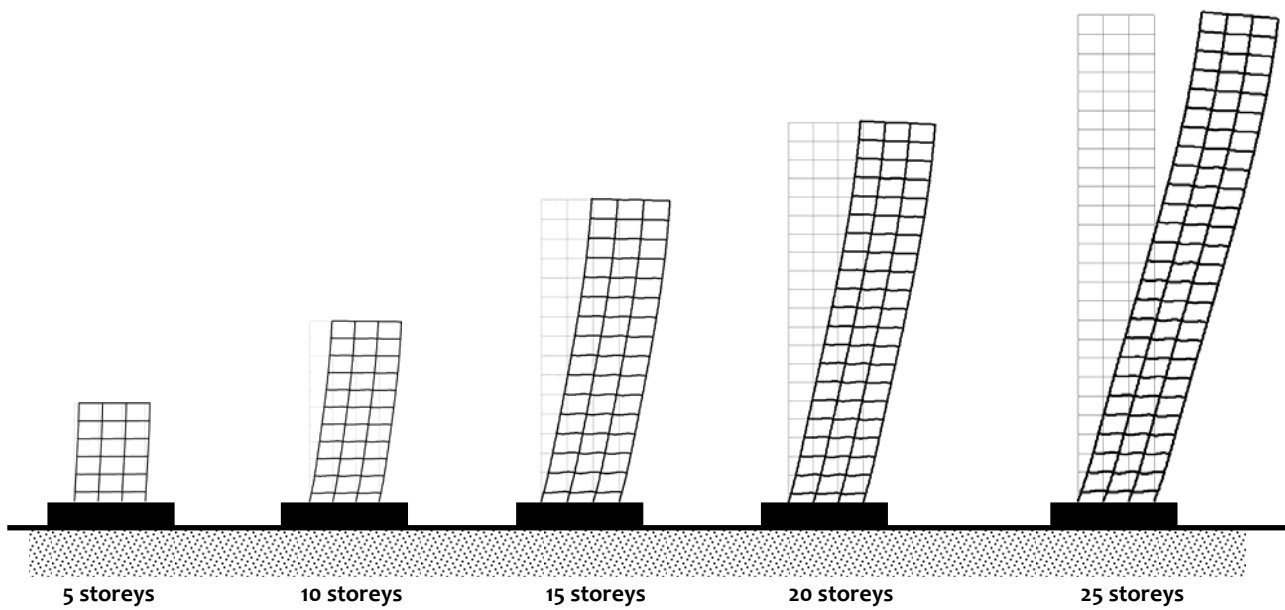


Figure 3.27: *Lateral deformation profiles:* Deformed shapes of 5, 10, 15, 20 and 25 storey buildings

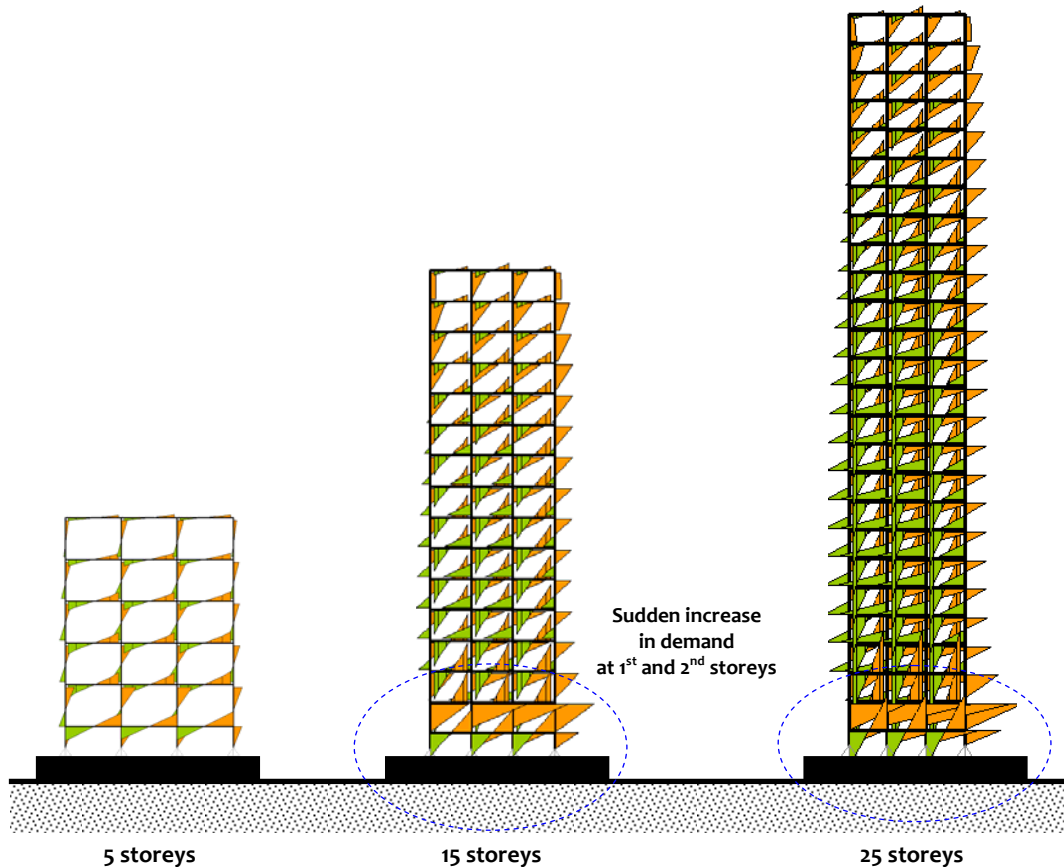


Figure 3.28: *Effect of Slenderness Ratio:* Large bending moment demand on first storey beams in buildings with large slenderness ratio

3.2.2 Structural Systems and Components

Using an appropriate structural system is critical to good seismic performance of buildings. While *moment-frame* is the most commonly used lateral load resisting structural system, other structural systems also are commonly used (Figure 3.29) like *structural walls*, *frame-wall system*, and *braced-frame system*. Sometimes, even more redundant structural systems are necessary, e.g., *Tube*, *Tube-in-Tube* and *Bundled Tube systems* are required in many buildings to improve their earthquake behaviour. These structural systems are used depending on the size, loading, and other design requirements of the building. One structural system commonly used poses special challenges in ensuring good seismic performance of buildings; this is the *Flat slab-column system*. The system makes the building flexible in the lateral direction and hence the building deforms significantly even under small levels of shaking. Further, it has relatively low lateral strength, and therefore ductility demand during strong earthquake shaking tends to be large; many times, such levels of ductility cannot be incorporated in buildings with flat slab-column system. This structural system should not be used without introducing in the building stiff and strong lateral force resisting elements, like *structural walls* and *braces*.

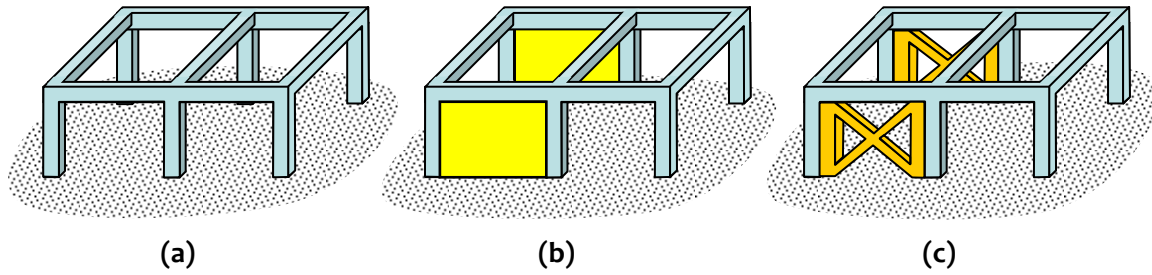


Figure 3.29: Common structural systems employed in buildings: (a) Moment frames, (b) Moment frames with structural walls, and (c) Braced moment frames. Walls and braces shown are shown only along one direction in plan; but designers can choose to provide them along both directions.

(a) Moment Frame Systems

Moment frames consist of a grid of vertical (*i.e.*, columns) and horizontal (*i.e.*, beams) members (Figure 3.29a). They resist lateral loads through axial forces, bending moment and shear force generated in both beams and columns (Figure 3.30). Beam and column sections should be designed as under-reinforced sections, and thereby, can be expected to undergo ductile behaviour; brittle shear failure must be prevented through capacity design procedures. While deciding the structural configuration of the building, predominant flexural behaviour in beams and columns should be facilitated. This can be achieved by using relatively long frame members; short beams and columns attract large forces and are susceptible to fail in a brittle manner.

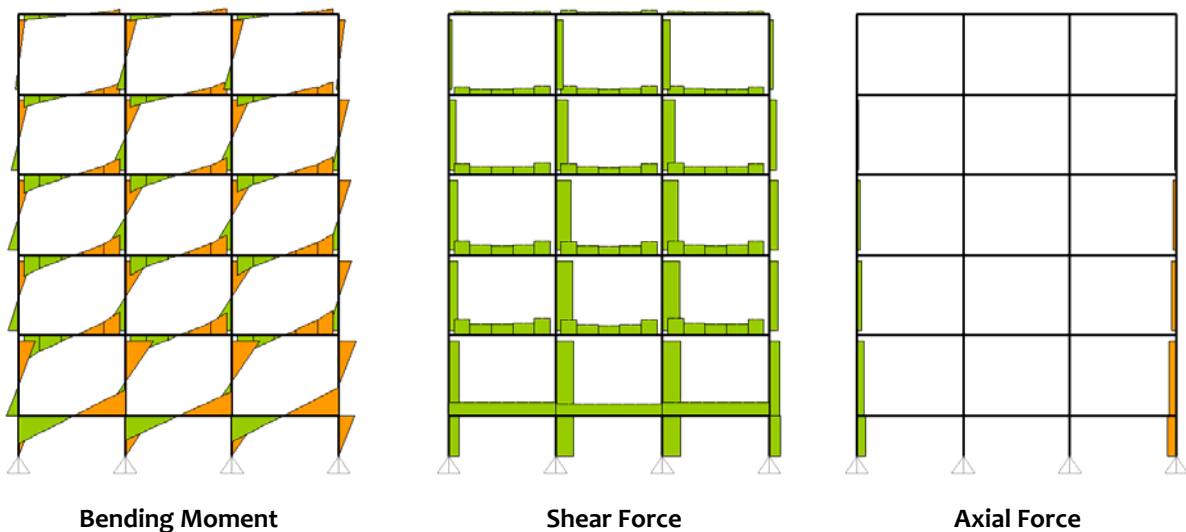


Figure 3.30: Behaviour of moment frames: Bending moment, shear force and axial force diagrams in the benchmark building having moment frames

Structural members are classified as *flexure-dominated* and *shear-dominated* depending on the type of deformation that dominates, *i.e.*, *flexure* or *shear*. The span to depth ratio (L/D) of a member is the critical factor governing its deformation behaviour. For a member (say, with rectangular cross-section of width b and depth D , and length L) framing at one end only, the ratio β of its *pure flexural translational stiffness* to *pure shear translational stiffness* is given by

$$\beta = \frac{3EI/L^3}{GA_s/L} = \frac{3E\left(\frac{bD^3}{12}\right)/L^3}{G(bD)/L} = \frac{(1+\nu)}{2} \left(\frac{D}{L}\right)^2. \quad (3.1)$$

And, for a similar member framing at both ends, β is given by

$$\beta = \frac{12EI/L^3}{GA_s/L} = \frac{3E\left(\frac{bD^3}{12}\right)/L^3}{G(bD)/L} = 2(1+\nu) \left(\frac{D}{L}\right)^2. \quad (3.2)$$

Thus, L/D ratio critically determines the mode of deformation of the member. In the above, E is the modulus of elasticity, G the shear modulus, ν the Poisson's ratio, and A_s the area resisting shear. Examples of the two cases in frames are shown in Figure 3.31 for columns and beams.

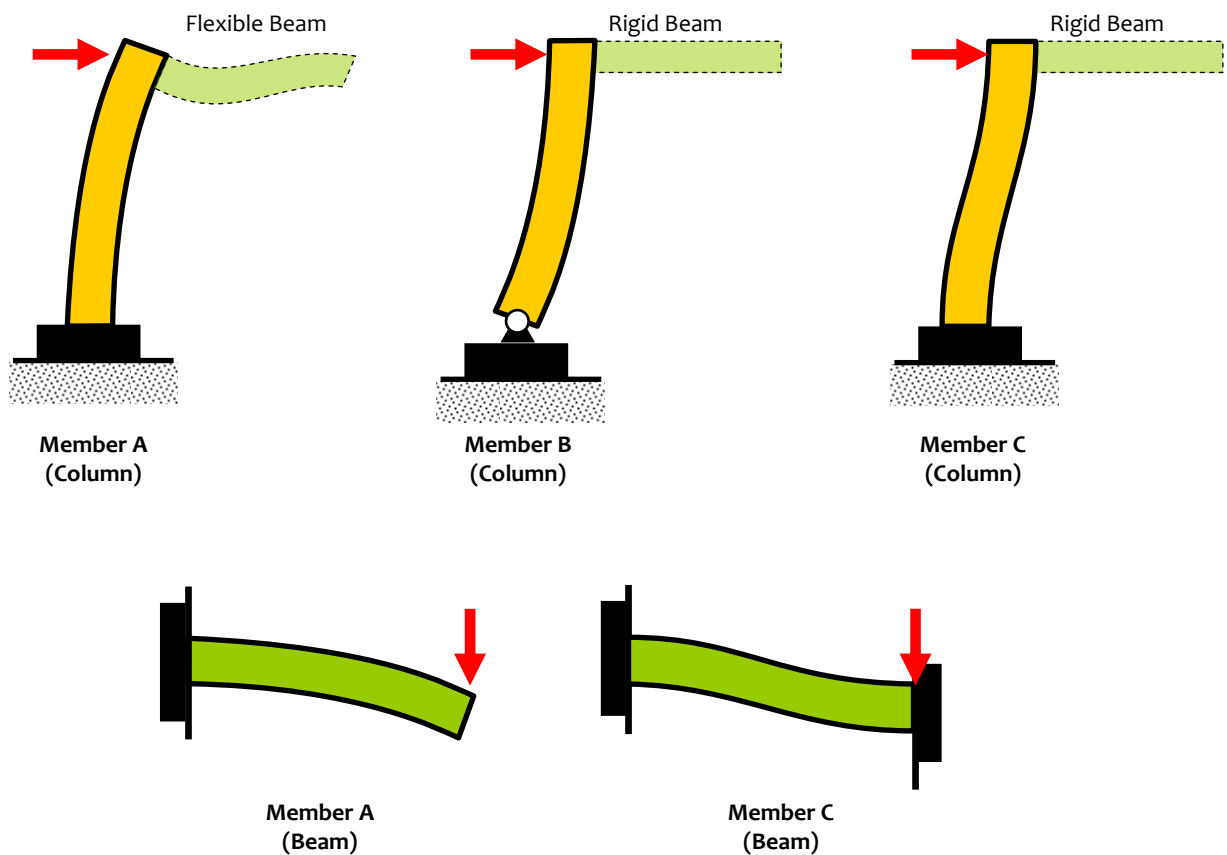


Figure 3.31: Member flexural deformation: Flexural deformations of a member depend on its end restraints

The variation of β with L/D is shown in Figure 3.32 of concrete beams of 300mm×1000mm cross-section. With increase in L/D ratio, flexural stiffness of the member decreases and hence β decreases. Thus, the deformation is primarily dominated by flexural action in members with large L/D ratios (Figure 3.33). On the contrary, flexural stiffness of a member increases significantly, and hence β increases rapidly, with decrease in L/D ratio below 1.0. In this range ($L/D < 1.0$) the deformation is governed by shear action (Figure 3.33). Thus, load transfer mechanism changes from flexure-type (*Bernoulli's Beam type*) to shear-type (*strut and tie type*) with decrease in L/D ratio (Figure 3.34).

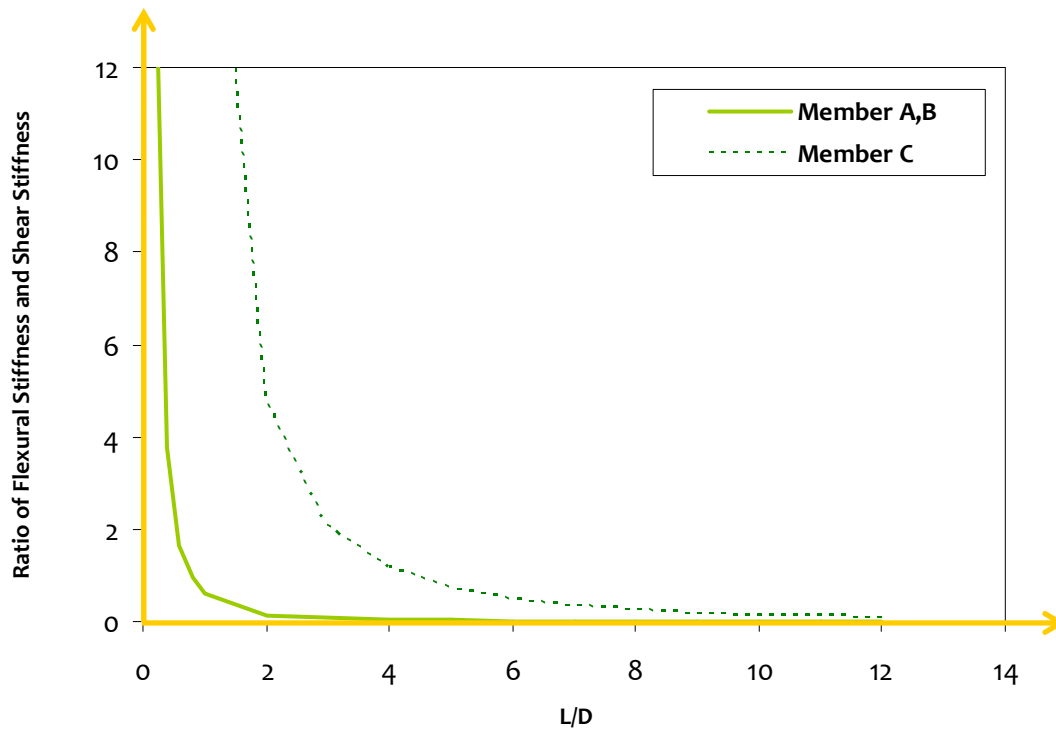


Figure 3.32: Role of Relative Translational Stiffness: Influence of L/D ratio on β of frame members

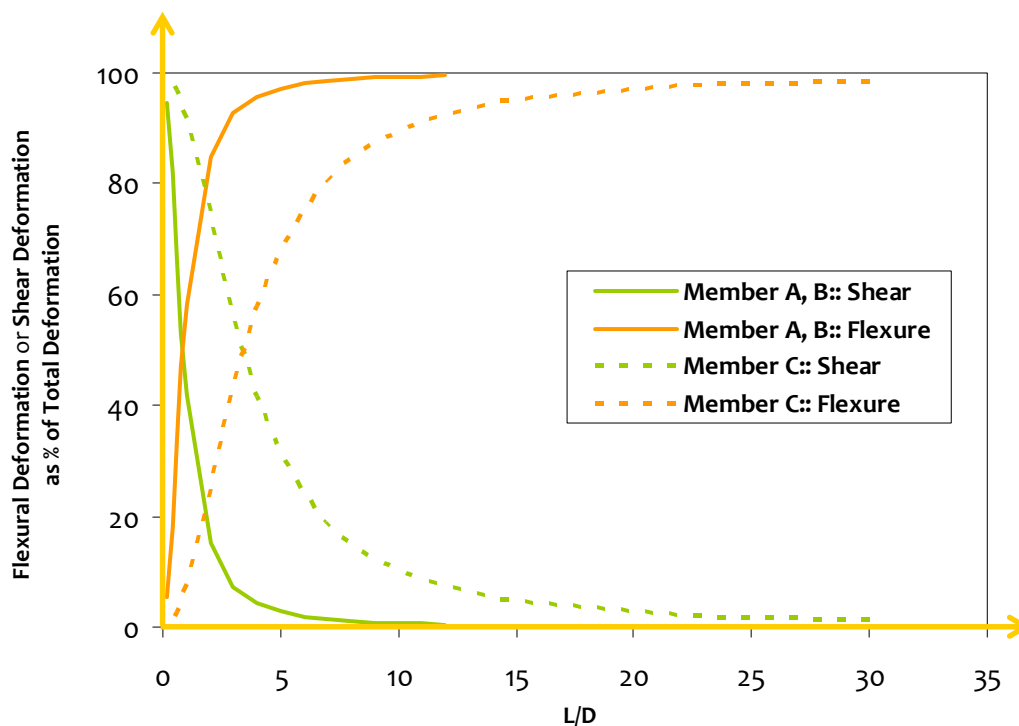


Figure 3.33: Member Behaviour: Relative share of flexural and shear action in overall transverse deformation

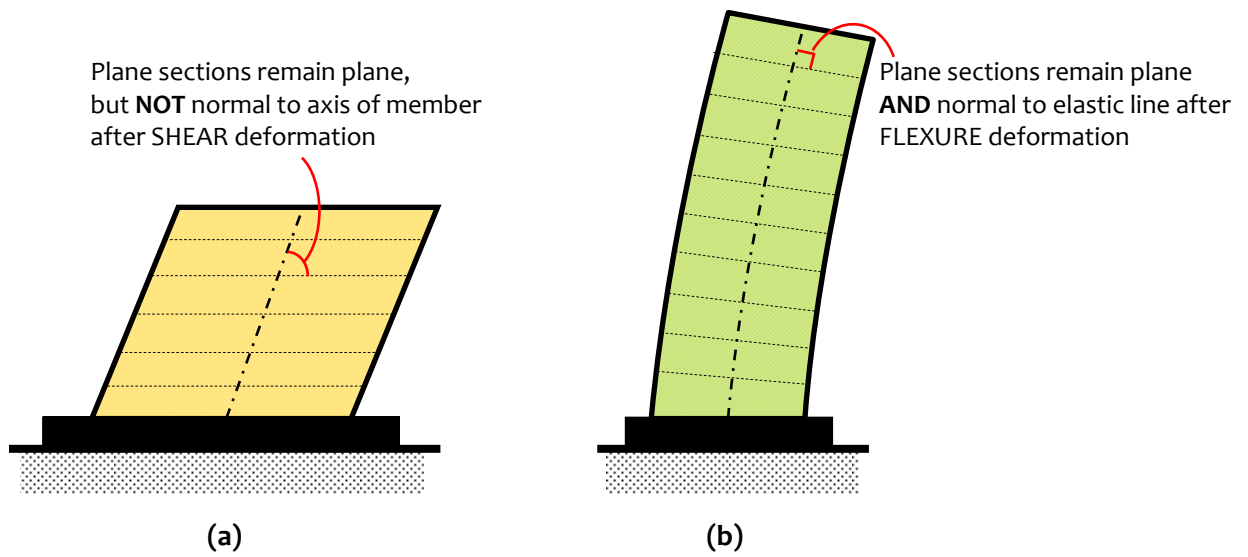


Figure 3.34: Member Deformation: Deformed shapes of cantilevers with predominant (a) Shear deformation, and (b) Flexure deformation

Consider the two in-plan modifications of the five-storey benchmark building (Figure 3.2). These are (i) Building A with only two 8m long bays in X-direction, and (ii) Building B with reduced 2m middle bay in place of regular 4m bay in Y-direction (Figure 3.35). Design equivalent lateral loads are applied on these two buildings. The 8m long beams (along X-direction in Building A) undergo good flexural action and attract large bending moments, but small shear force (compared to 4m long beams in the same X-direction in Building B). This leads to large flexural deflection of the long beams, and also increases the moment and shear demand on the internal columns in Building A. On the other hand, the short 2m beams (in Y-direction in Building B) attract large shear force, but small bending moment (compared to 4m long beams in the same Y-direction in Building A; Figure 3.36). Thus, short beams of the same size are prone to brittle shear failure, while under-reinforced ductile flexural actions can be mobilized in long beams. However, it is best to have near uniform spans and loading in each direction of buildings to ensure uniform distribution of both bending moment and shear force in all frame members.

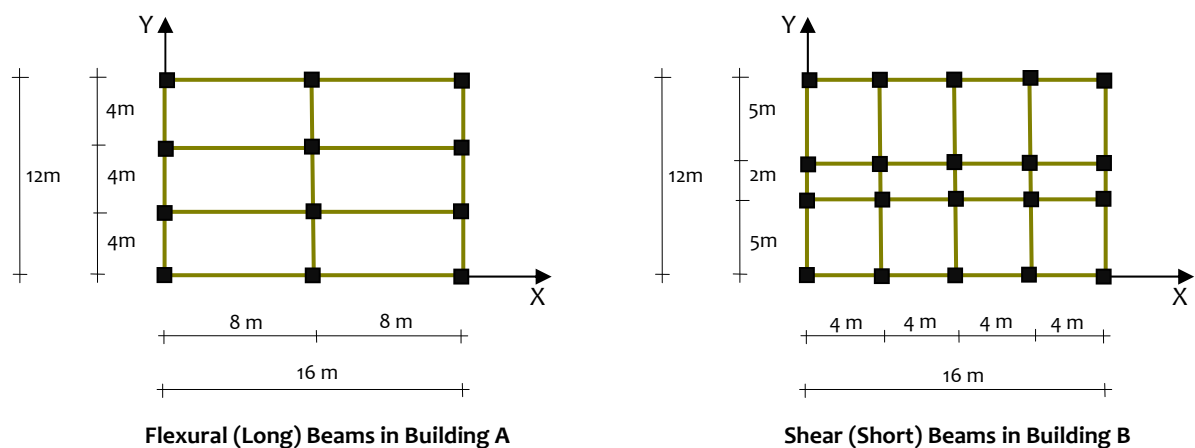
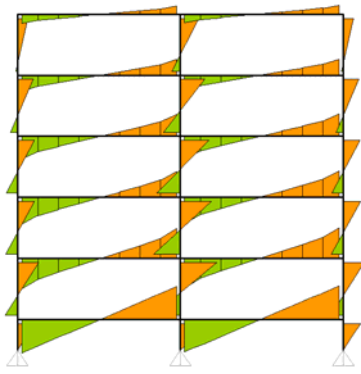
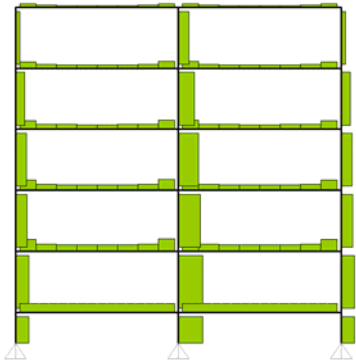
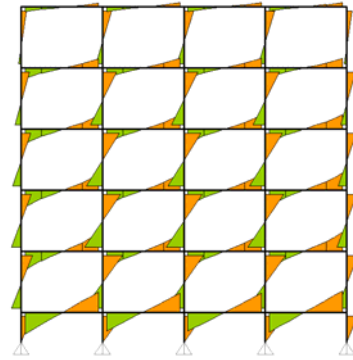


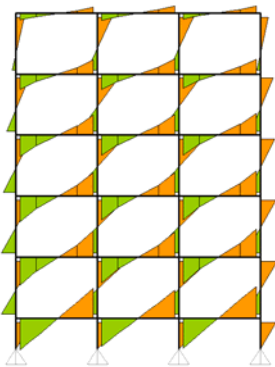
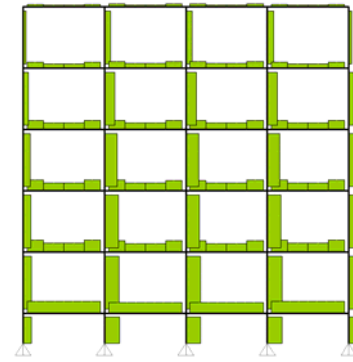
Figure 3.35: Effect of beam span: Long span beams resist load through flexure while short span beams through shear



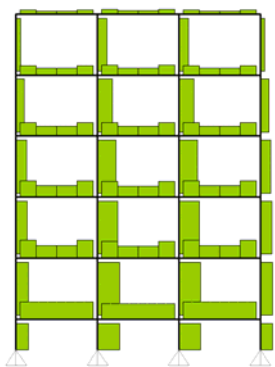
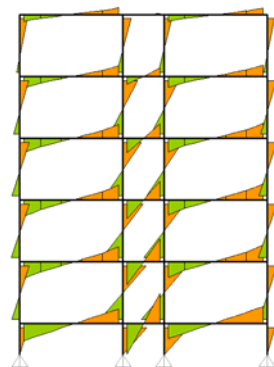
Bending Moment
in X-direction



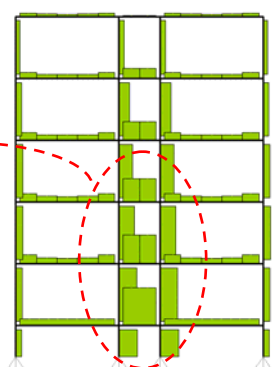
Shear Force
in X-direction



Bending Moment
in Y-direction



Shear Force
in Y-direction



Building A

Building B

Figure 3.36: *Effect of beam span:* Long span beams resist load through flexure while short span beams through shear

Gravity loads and lateral loads cause different moment actions on moment-resisting frames (Figure 3.37). Gravity loads cause reasonably similar moments in columns (Figure 3.38), but earthquake-induced lateral loads cause dissimilar moments. In the latter case, the load transfer in a moment frame building depends critically on relative ratio (I_b/I_c) of moments of inertia of adjoining beams and columns (Figure 3.39). If moments of inertia (I_b) are *small* of beams inter-connecting the columns, then the columns are not restrained rotationally at the beam levels; the columns bend almost like *overall cantilevers* from their bases (Figure 3.39a). And, if moments of inertia (I_b) are *large* of beams inter-connecting the columns, then the columns are restrained rotationally significantly at the beam levels; the columns bend in *double curvature* between the levels of the beams (Figure 3.39c). The first case results in *cantilever action of each column with beams not resisting this column bending*; this is called the *FLEXURE deformation type*. And, the latter results in *special frame action of columns with beams remaining almost straight*; this is called *SHEAR deformation type*. In building frames designed to resist *only* gravity loads, usually the beams are stiffer than columns, and hence the latter happens. And, when building frames are designed to resist lateral loads *also*, usually the columns are stiffer and stronger. The intermediate ratio of moments of inertia of beams and columns results in a situation in between (Figure 3.39b).

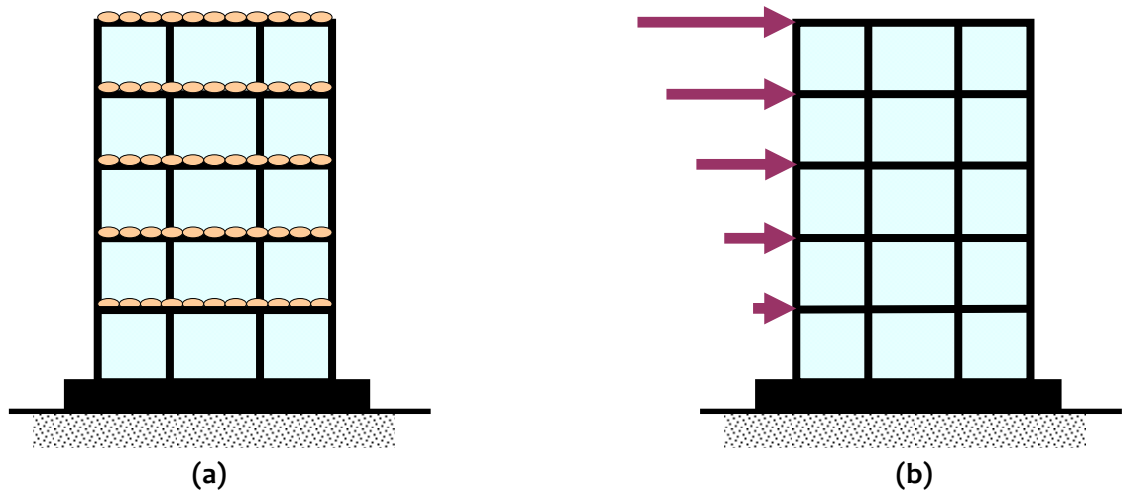


Figure 3.37: Two basic load types on moment frames: (a) *Gravity Loads*, and (b) *Lateral Loads*

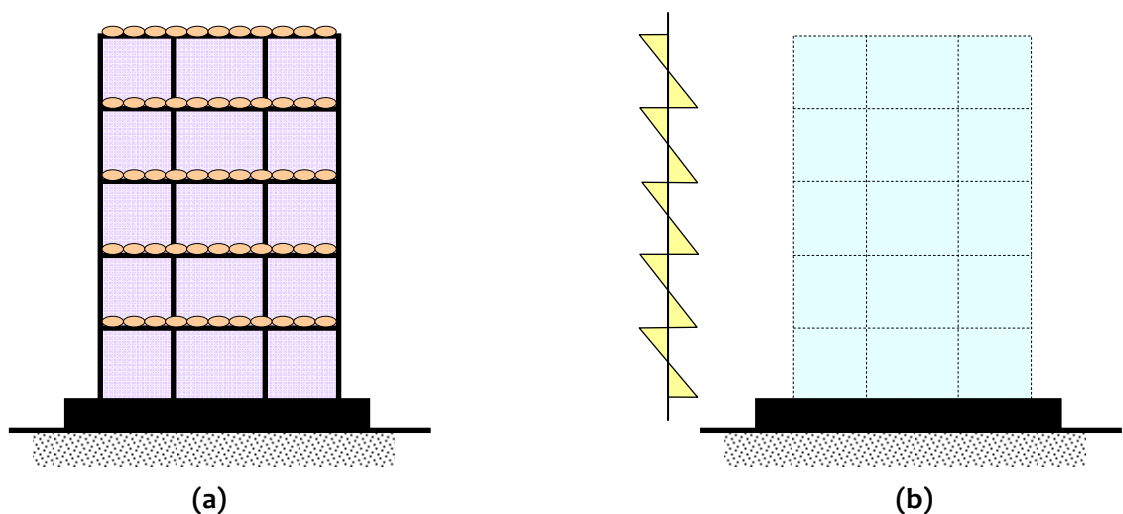


Figure 3.38: *General case of overall frame action: Bending moment diagram due to Gravity Load on moment frame*

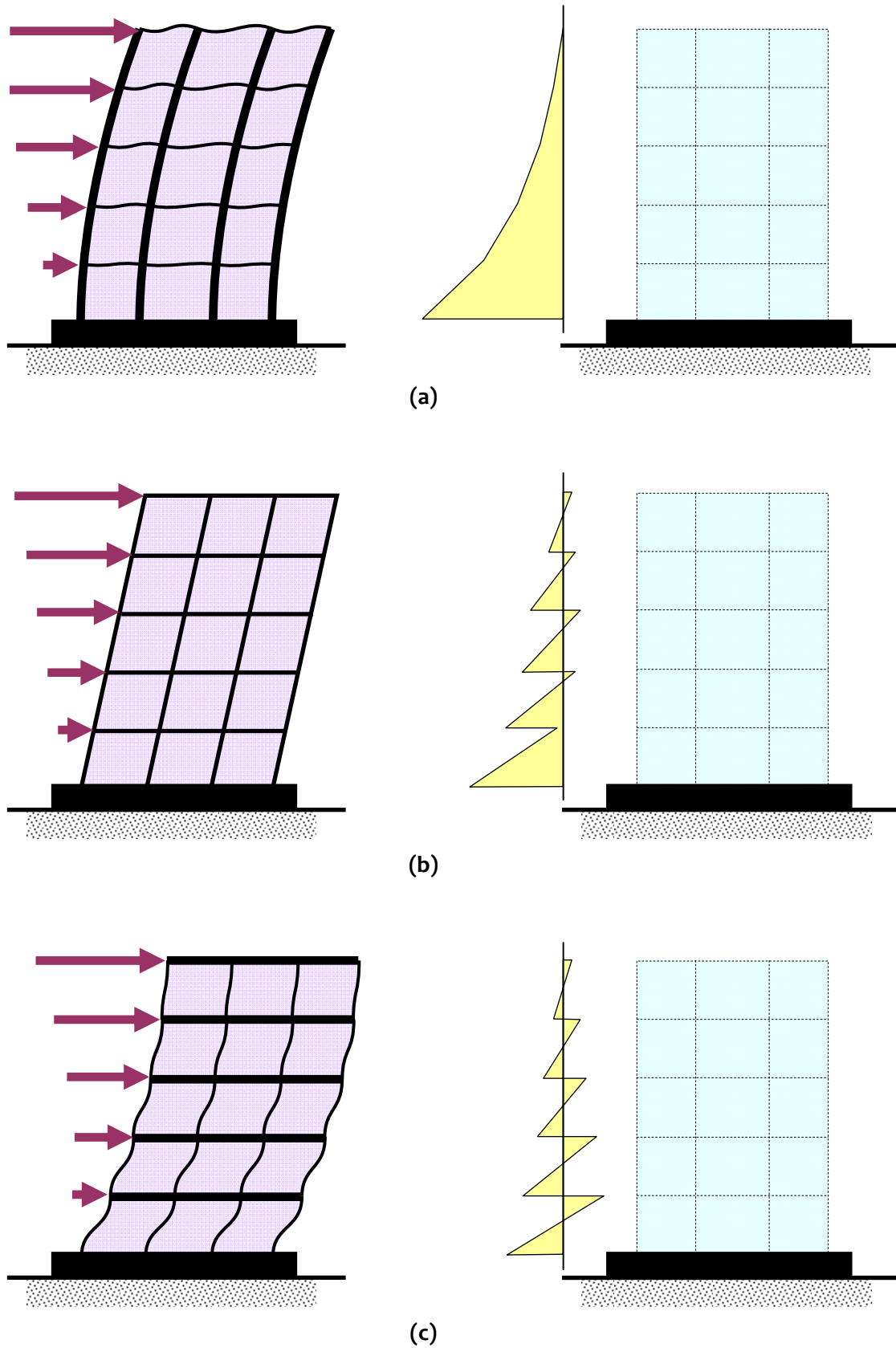


Figure 3.39: Two extreme cases of overall frame action: (a) *FLEXURE Deformation Mode:* Overall cantilever column action owing to extremely rotationally flexible beams ($I_c/I_b \rightarrow \infty$), (b) *INTERMEDIATE Deformation Mode:* Combined column-beam action owing to reasonably close rotationally flexible columns and beams, and (c) *SHEAR Deformation Mode:* Double-curvature column action owing to extremely rotationally stiff beams ($I_c/I_b \rightarrow 0$)

A comparison of bending moment diagrams of a building is shown in Figure 3.40, where relative beam-column stiffness is varied. For presenting a fair comparison, the bending moments are drawn under the same lateral load of 10% of the seismic weight of the building. The three actions discussed in the foregoing discussion are shown in Figure 3.40. Further, assumption is invalid that the point of contra flexure in a column is at mid height as cantilever action dominates. *Flexure deformation mode* of the frame governs when $I_c/I_b \rightarrow \infty$, and *shear deformation mode* when $I_c/I_b \rightarrow 0$. Bending moment diagrams of the benchmark building are shown in Figure 3.41 under different combinations of beam and column depths; transition is evident from shear deformation mode of overall deformation to flexure deformation mode.

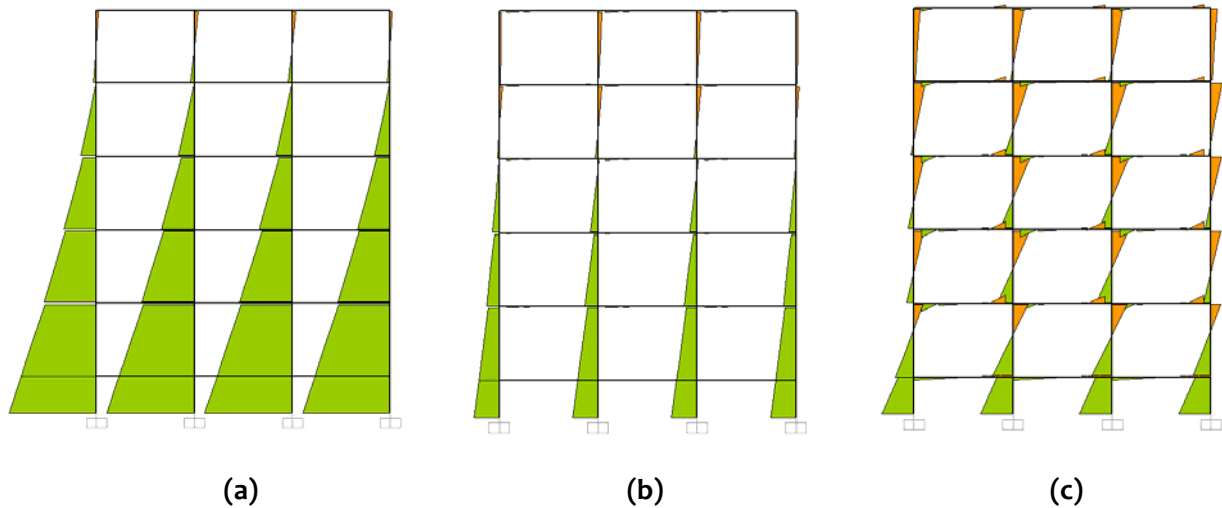


Figure 3.40: Bending moment in members of buildings under lateral load: (a) $I_c/I_b = 1000$ (Flexure deformation), (b) $I_c/I_b = 512$, and (c) $I_c/I_b = 7$ (Shear deformation)

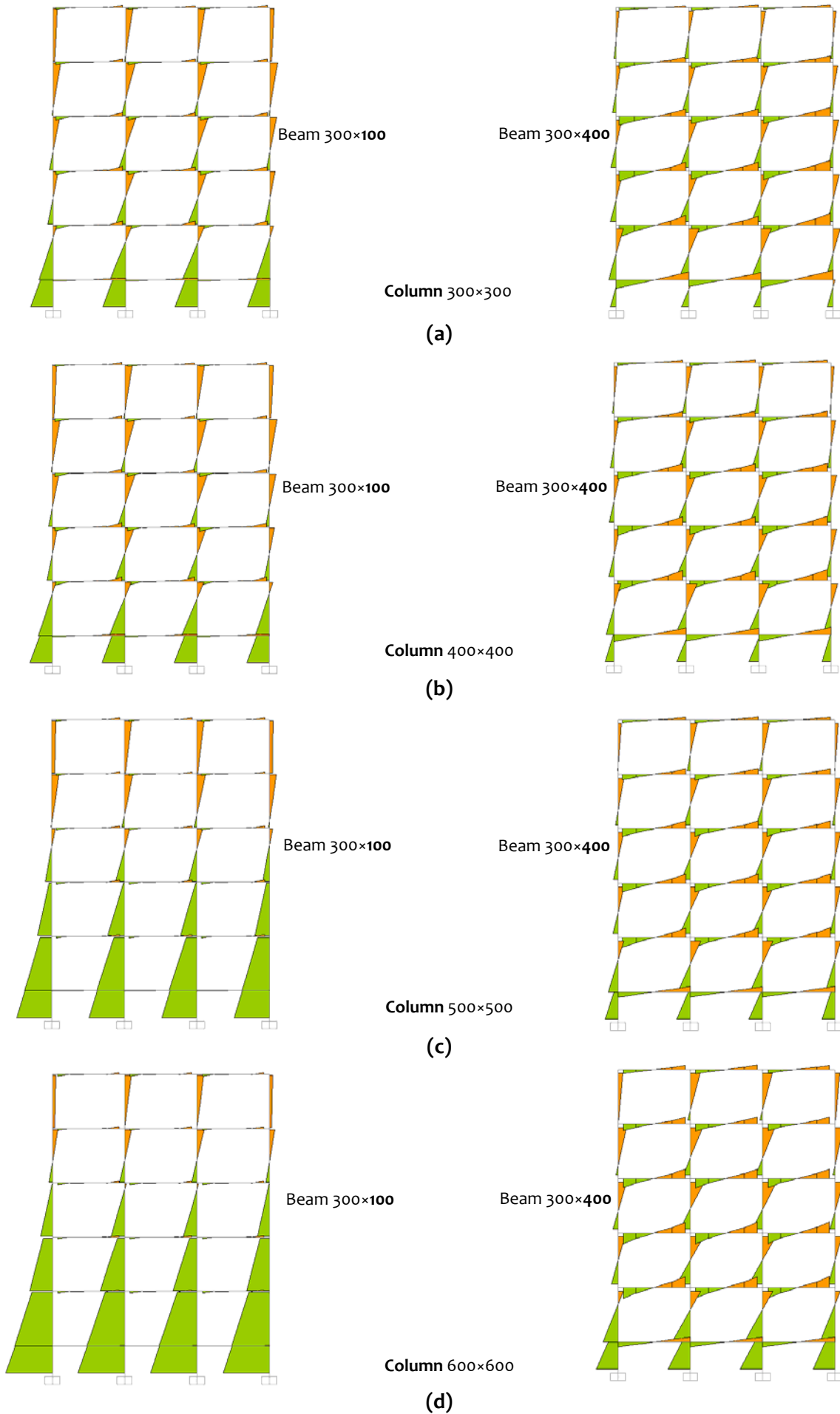
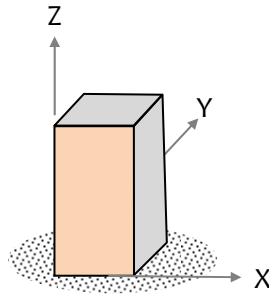
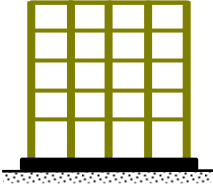
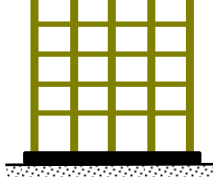
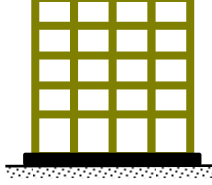


Figure 3.41: Bending moment in members of benchmark building subjected to lateral load with different combinations of beams and columns: Bending moment increases in column with reduction in beam-to-column flexural stiffness

Animation Set 307

Load Transfer Mechanism Effect of Flexural Stiffness of Beams and Columns



Large ratio of I_c / I_b	Moderate ratio of I_c / I_b	Low of I_c / I_b
		
<p><u>Cantilever Action</u></p>	<p><u>Intermediate action</u></p>	<p><u>Frame action</u></p>
<p>Click on the 3 items above to see the animation of the load transfer mechanism Best when viewed using Windows Media Player</p>		

(b) Structural Wall-Frame Systems

Earthquake resistant buildings should possess, at least a minimum lateral stiffness, so that they do not swing too much during small levels of shaking. Moment frame buildings may not be able to offer this always. When lateral displacement is large in a building with moment frames only, *structural walls*, often commonly called *shear walls*, can be introduced to help reduce overall displacement of buildings, because these vertical plate-like structural elements have large in-plane stiffness and strength. Therefore, the structural system of the building consists of moment frames with specific bays in each direction having structural walls (Figure 3.29b). Structural walls resist lateral forces through combined axial-flexure-shear action. Also, structural walls help reduce shear and moment demands on beams and columns in the moment frames of the building, when provided along with moment frames as lateral load resisting system. Structural walls should be provided throughout the height of buildings for best earthquake performance. Also, walls offer best performance when rested on hard soil strata.

Consider the five-storey building, but with structural walls as shown in Figure 3.42. The first case differs from the rest in the position of the structural walls in both direction – the walls are at the building periphery in the first case, while they are placed near the centre in the others. The last two cases represent buildings with twice wall area in the Y-direction; in the last case, two short (one-bay) walls are combined to form one long (two-bay) wall. Structural walls, owing to their large lateral stiffness, draw most of the lateral force and thereby help reduce demands on columns and beams. This is seen in Figure 3.43; bending moment, shear force and axial force demands on beams and columns are significantly reduced by introduction of structural walls (at periphery).

But, it is not sufficient to provide structural walls in buildings; their location in a building governs the overall response of the building. Consider three buildings with same number and size of structural walls but at different locations; structural walls at periphery, structural walls in inner bays, and structural walls forming a core at the center of the building. The buildings are subjected to gravity loads and lateral force equal to 10% of building weight in the two plan directions. Natural periods of the first three modes of oscillation and roof displacements of these four buildings are listed in Table 3.8. While introduction of structural walls cause reduction in (a) lateral displacement, and (b) natural periods of oscillation, placing the same structural walls towards the center of the building allows flexibility for buildings to undergo *torsion*. In the extreme case, where the four structural walls are interconnected at the center to form a core, torsion becomes the first mode of oscillation and is not desirable. Clearly, structural walls are most effective when placed at the periphery of buildings.

Also, it is useful to have one long structural wall than two short ones separated by interconnecting beams. Consider the last two buildings shown in Figure 3.42. Although, wall area is same in both the buildings in the Y-direction, the building with longer structural wall is much stiffer than the others, and hence, offers more resistance to lateral motion – lateral displacement and force demands on beams and columns are significantly reduced by using double length walls (Table 3.9 and Figure 3.44).

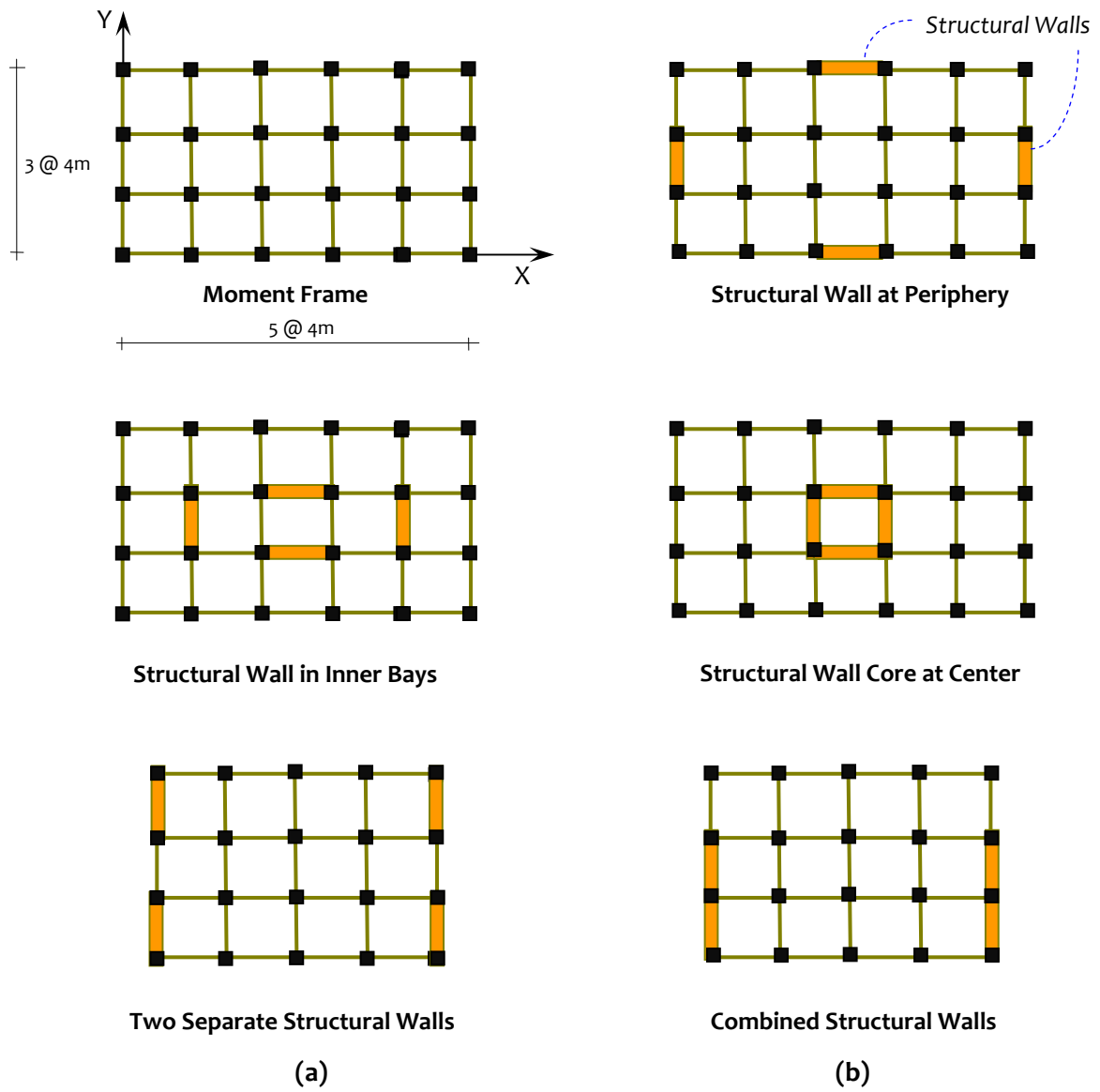


Figure 3.42: Buildings with structural wall: Location of structural wall is important for seismic performance of buildings

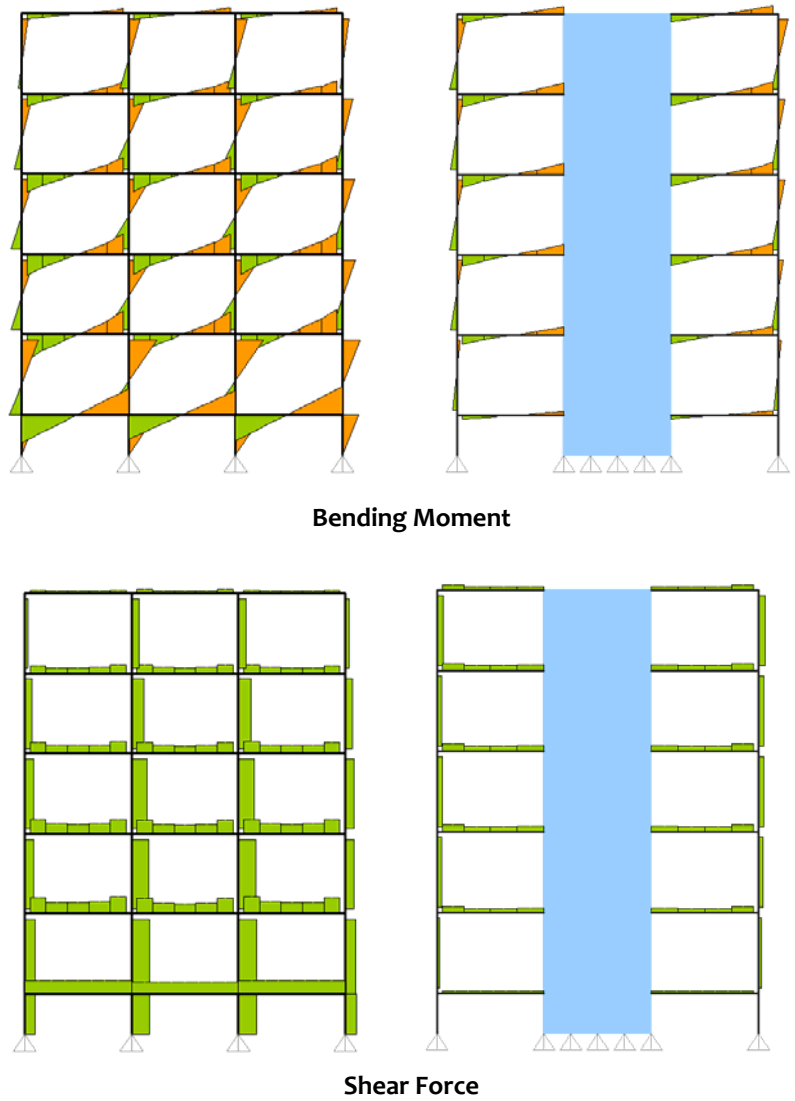
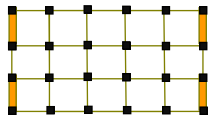
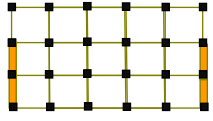


Figure 3.43: Building with structural walls at periphery: Demands on beams and columns are significantly reduced in buildings with structural wall

Table 3.8: Modes of oscillation in buildings with structural walls: structural walls at center of buildings are less efficient

Case				
Mode 1	Y translation (0.74s)	Y translation (0.48s)	X translation (0.48s)	Torsion (0.37s)
Mode 2	X translation (0.72s)	X translation (0.47s)	Y translation (0.47s)	Y translation (0.34s)
Mode 3	Torsion (0.65s)	Torsion (0.33s)	Torsion (0.47s)	X translation (0.33s)
Roof displacement in X direction	21.6 mm	11.9 mm	11.5 mm	5.9 mm
Roof displacement in Y direction	23.4 mm	12.4 mm	10.9 mm	6.0 mm

Table 3.9: Modes of oscillation in buildings with structural walls: Long structural walls are more efficient than a number of short ones

		
Mode 1	X translation (0.91s)	X translation (0.89s)
Mode 2	Y translation (0.38s)	Y translation (0.27s)
Mode 3	Torsion (0.30s)	Torsion (0.25s)
Roof displacement in Y direction	8.1 mm	3.4 mm
Base Shear	759 kN	784 kN

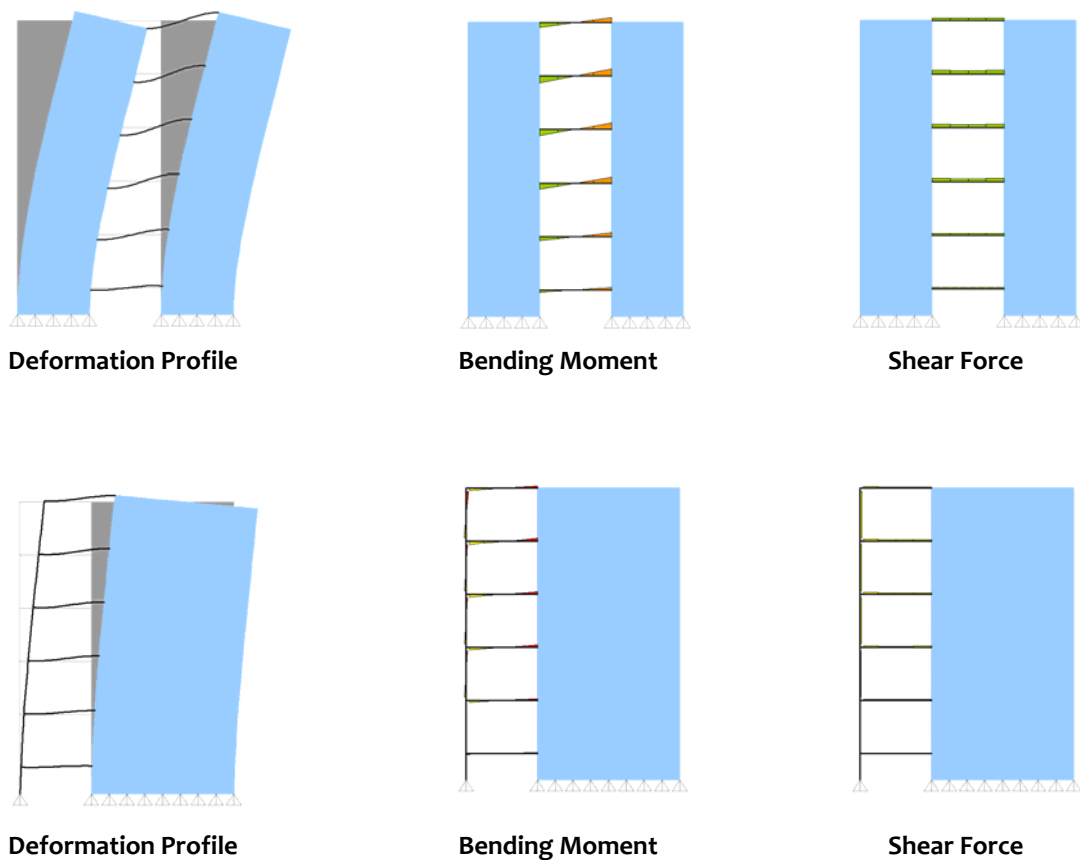
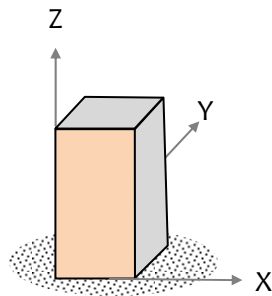
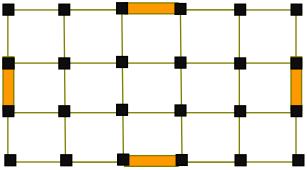
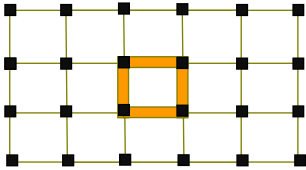


Figure 3.44: Buildings with structural walls: Long structural walls are more efficient than a number of short ones

Animation Set 308

Three-dimensional modes shapes of buildings Effect of Location of Shear Wall



<p>Shear walls at periphery of building</p> 	<p>Shear walls at center of building</p> 
<p>First Mode <u>Translational in Y-direction</u></p>	<p>First Mode <u>Torsional Mode about Z-axis</u></p>
<p>Second Mode <u>Translational in X-direction</u></p>	<p>Second Mode <u>Translational in Y-direction</u></p>
<p>Third Mode <u>Torsional Mode about Z-axis</u></p>	<p>Third Mode <u>Translational in X-direction</u></p>
<p>Click on the 6 items above to see the animation of the mode shapes Best when viewed using Windows Media Player</p>	

(c) Braced Frame Systems

The structural system consists of moment frames with specific bays provided with braces throughout the height of the building (Figure 3.29c). Braces are provided in both plan directions such that no twisting is induced in the building owing to unsymmetrical stiffness in plan. Braces help in reducing overall lateral displacement of buildings, and in reducing bending moment and shear force demands on beams and columns in buildings. The earthquake force is transferred as axial tensile and compressive force in the brace members. Various types of bracings can be used including global bracing along the building height (Figure 3.45). Consider the five-storey benchmark building with three types of local bracing systems namely, X-, *Chevron* and *K-bracing* systems (Figure 3.46). X- and Chevron braces effectively reduce bending moment, shear force and axial force demands on the beams and columns of the original frame and are commonly used (Figure 3.47). But, K-braces increases shear demand on columns and can cause brittle shear failure (Figure 3.47). Thus, some design codes prohibit use of K-braces in earthquake resistant design.

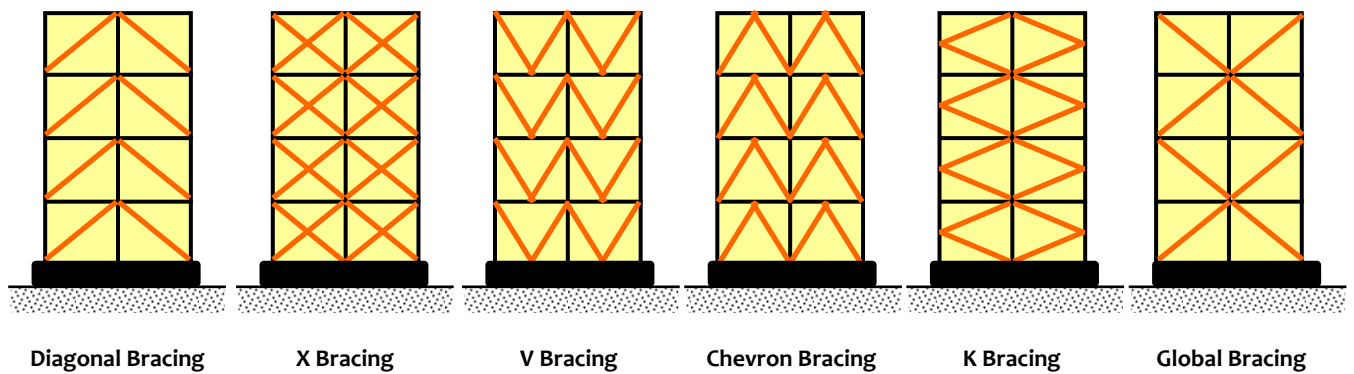


Figure 3.45: *Braced frames:* Different bracing types for use in buildings

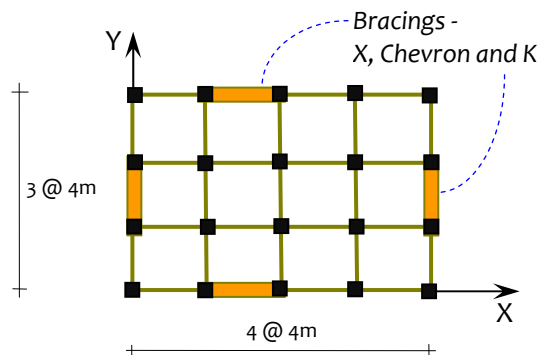
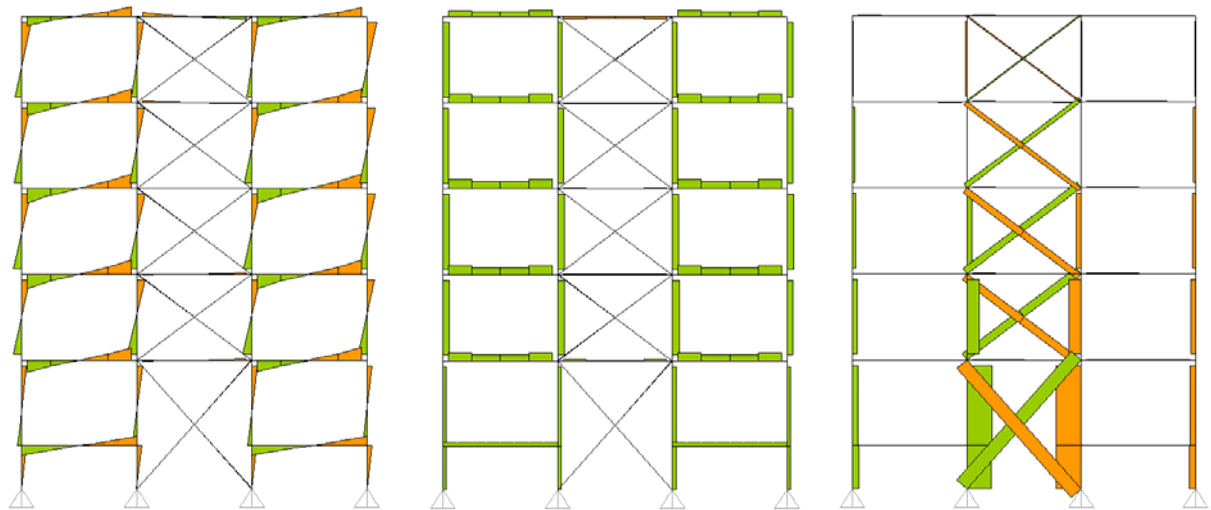
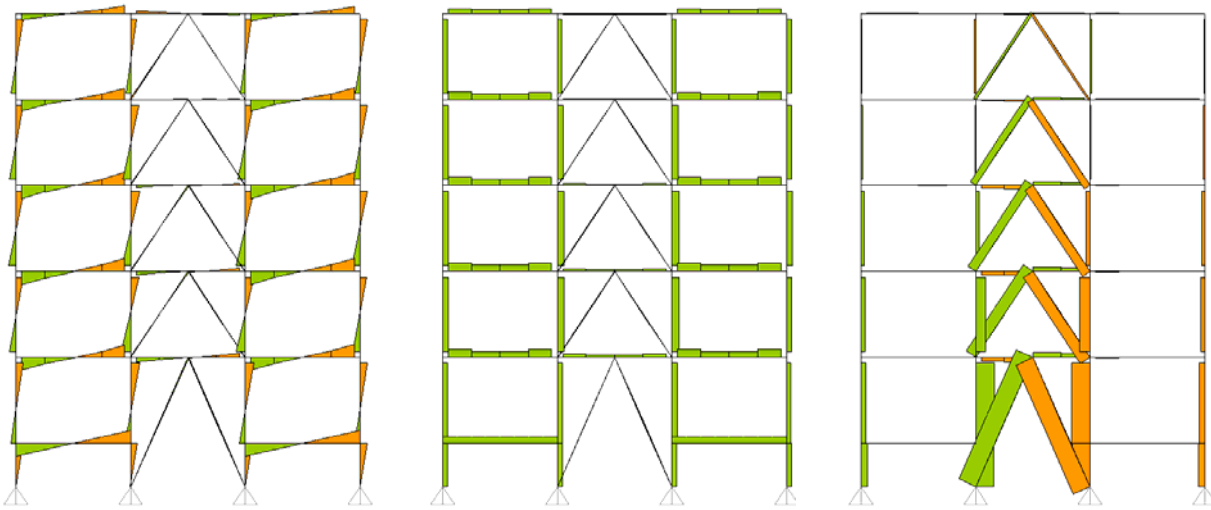


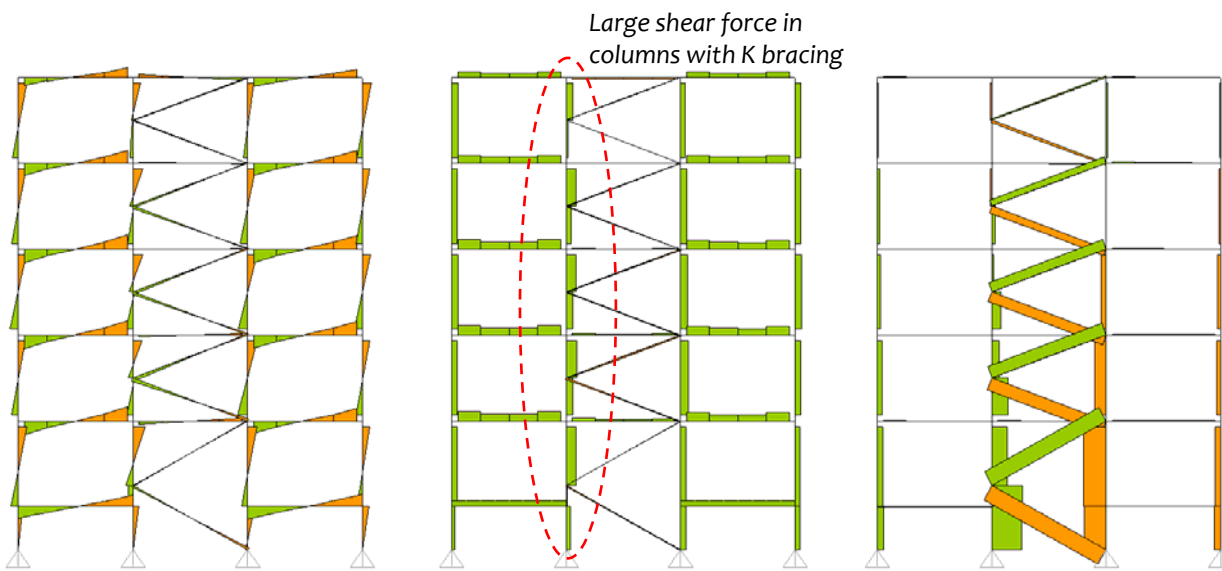
Figure 3.46: *Braced frames:* Location of bracing along the building periphery



X-BRACES



CHEVRON BRACES



Large shear force in columns with K bracing

K-BRACES

Bending Moment

Shear Force

Axial Force

Figure 3.47: Braced frames: X- and Chevron braces help reduce moment and shear demand on columns and beams, but not K-braces

Also, global braces are effective in reducing the force demands on main frame members, sometimes even more than structural walls. Consider three 20-storey buildings with moment frame, global braces and structural wall, whose plan geometry is as shown in Figure 3.48. The reduction in force demands on frame members (*i.e.*, beams and columns) in the building with global bracing is significant (Figures 3.49 - 3.51). In fact, bending moment and shear force demands on beams in the upper storeys are increased in the building with structural wall compared to the building with moment frame alone. This is because slender structural walls (as in tall buildings) also undergo significant lateral deformation, and in the process, impose large flexural rotation demand on the adjacent beams. This is seen in Figure 3.52, which shows the lateral deformation profiles of the three buildings; lateral drift is least in building with global braces. Thus, it is important to have intermediate floors with large and stiff outrigger beams to effectively transfer forces in buildings with structural walls. But, the structural walls in the example building cover only two inner bays, and thus are not effective fully.

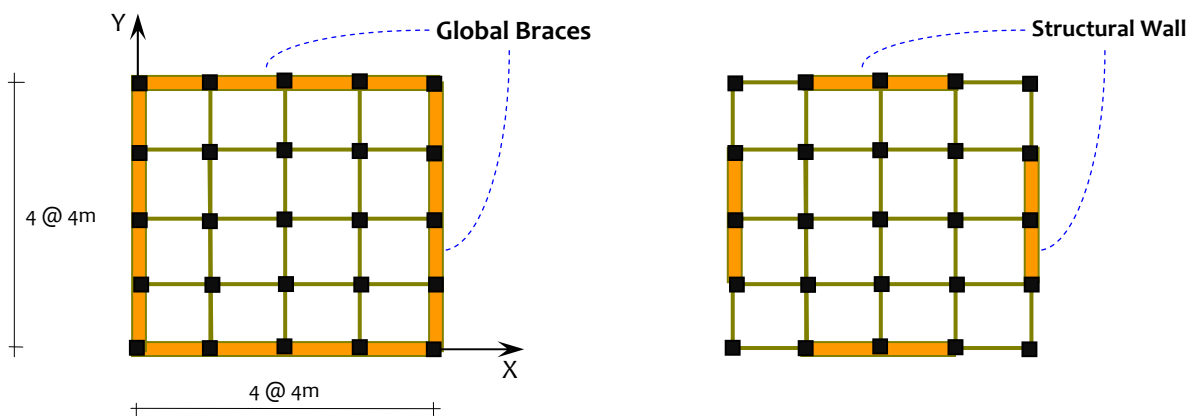


Figure 3.48: Global braces and structural wall in tall buildings: Plan of 20-storey buildings showing location of global braces and structural wall

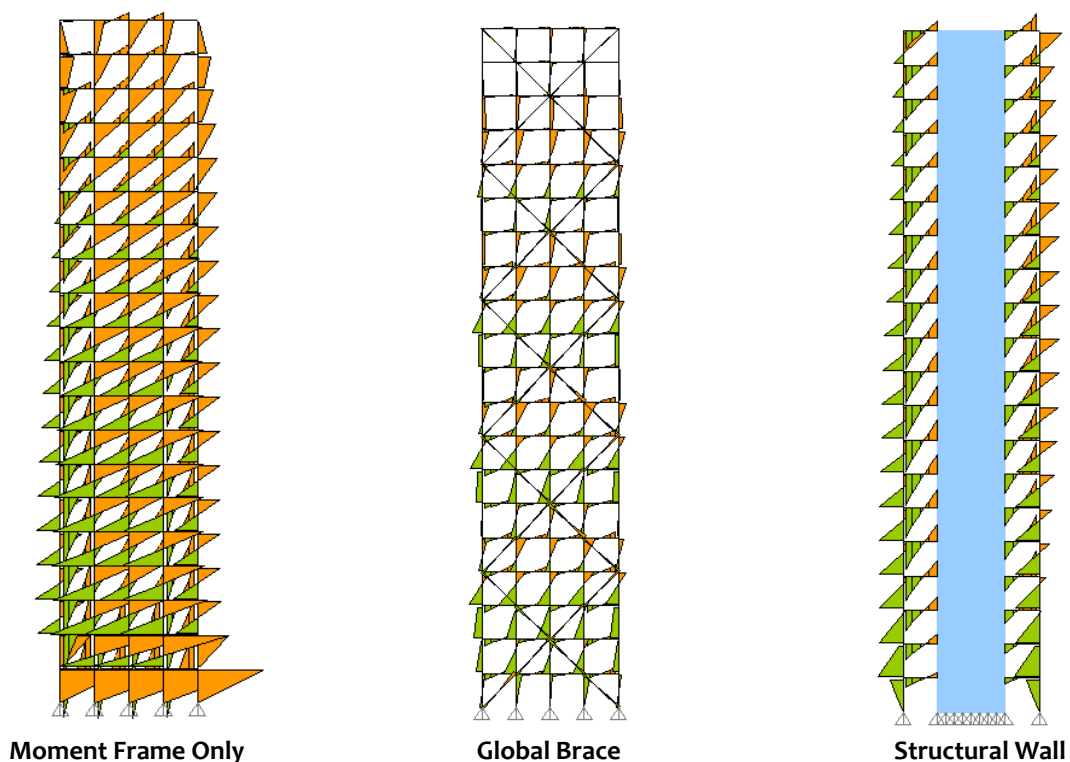
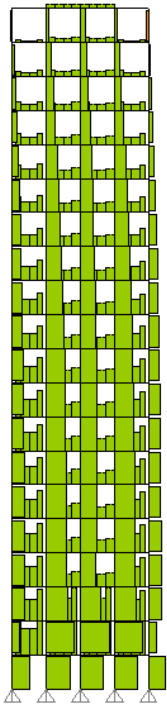
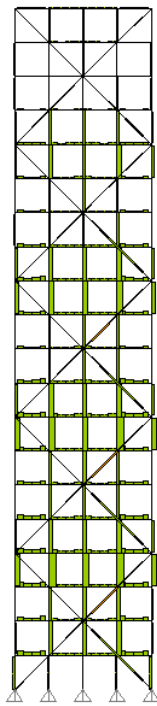


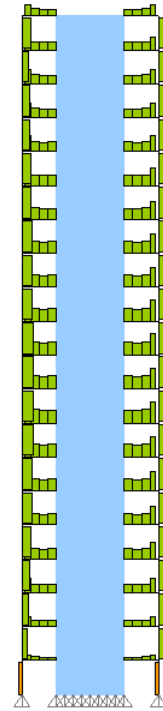
Figure 3.49: BENDING MOMENTS in buildings with no braces, global braces and structural wall: Maximum reduction in bending moment demand on columns is achieved by global braces



Moment Frame Only

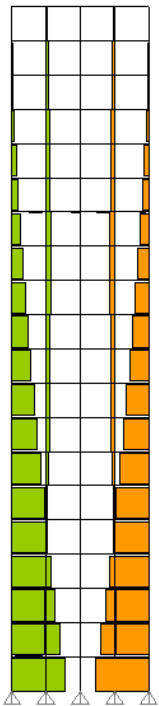


Global Brace

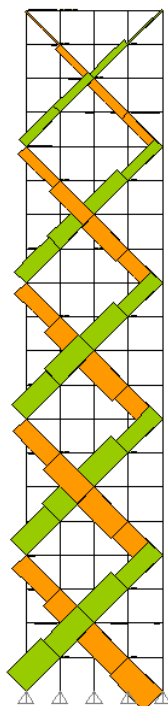


Structural Wall

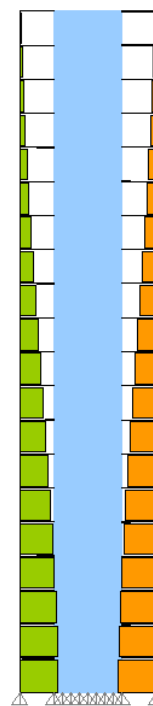
Figure 3.50: SHEAR FORCES in buildings with no braces, global braces and structural wall: Maximum reduction in shear force demand on columns is achieved by global braces



Moment Frame Only



Global Brace



Structural Wall

Figure 3.51: AXIAL FORCES in buildings with no braces, global braces and structural wall: Maximum reduction in axial force demand on columns is achieved by global braces

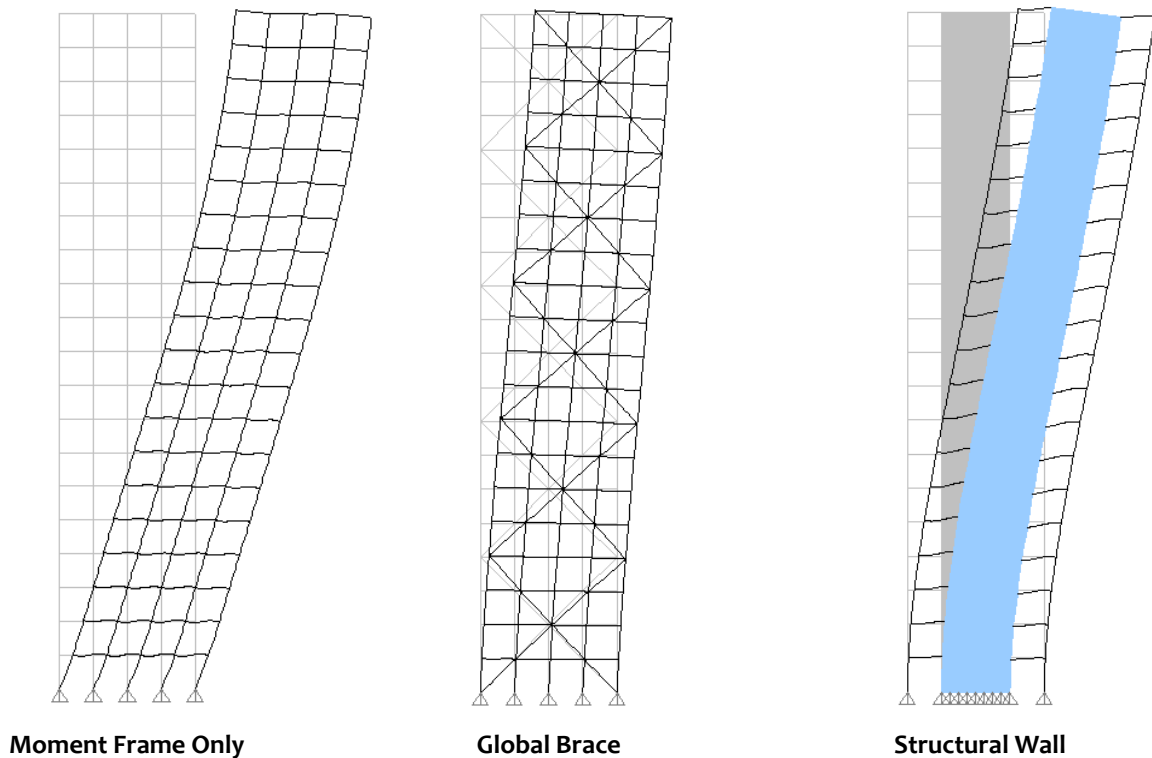


Figure 3.52: DEFORMATION PROFILES in buildings with no braces, global braces and structural wall: Lateral displacement is least in building with global braces, while it is maximum in (bare) moment frame buildings

(d) Tube System

For tall buildings, use of braced frames and structural walls alone (even though of reasonably sized members) may be insufficient to control their overall lateral displacement as well as the force demands on various structural members. In such cases, more rigid structural systems are required, like *Tube*, *Tube-in-Tube* and *Bundled Tube systems*, depending on the size and loads on the building.

Closely-spaced heavy columns forming a closed loop inter-connected with beams, together called the *tube*, forms the first part of the lateral load resisting system. Heavy reinforced concrete structural walls together creating a closed shaft, called as the *core*, form the other part. The *Tube System* consists of *one* perimeter tube with a central core (Figure 3.53). The inter-connection is important between the perimeter tube and the central core. A system of grid beams is used for this purpose, consisting of *primary beams* (those running between the perimeter columns and central core), *secondary beams* (those running between columns such that no column is left without being connected to the rest of the system), and *tertiary beams* (those running between beams and not connected to any column) (Figure 3.54). For smooth and uniform transition of forces to the peripheral frame, a grid of stiff and strong beams and columns is required. Perimeter tubes in buildings that have primary, secondary and tertiary beams carry more lateral force than perimeter tubes of buildings that either have primary beams only or have primary and secondary beams; denser grid of beams helps carry lateral forces away from the central core to the perimeter frame.

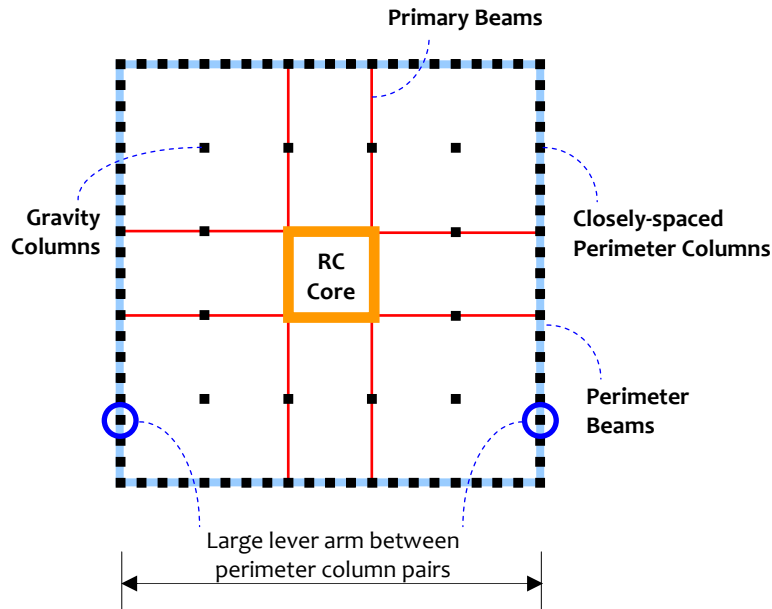


Figure 3.53: *Structural Elements in a Tube System:* Some columns (called *Gravity Columns*) are not necessarily connected with beams to either the Core or the Tube

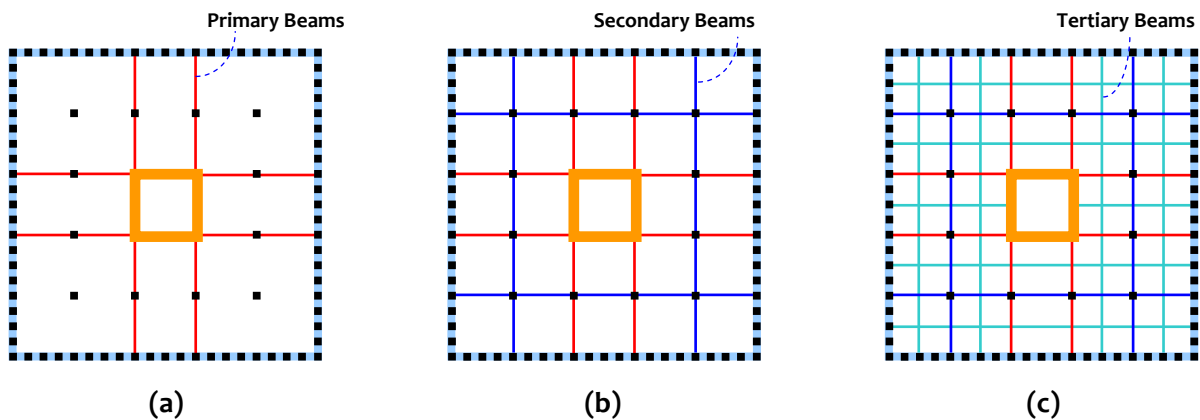


Figure 3.54: *Possible systems of beams in a Tube system:* Connection between the core and tube through (a) only *primary* grid of beams, (b) *primary* and *secondary* grid of beams, and (c) *primary*, *secondary* and *tertiary* grid of beams

This aspect of the Tube System that the perimeter draws most of the lateral force induced in the building during earthquake shaking, is in contrast to the normal building frame with a central core, wherein the perimeter frame (with columns separated far apart) carries small loads (Figure 3.55). In the traditional frame building with the central core, most of the lateral forces are carried by the central reinforced concrete core. The load transfer path carries the forces to the concrete core. As the lateral force travels down towards the base of the building, the force flows towards the more stiffened corners of the core in the form of axial tension and compression (Figure 3.56). Thus, the corners of the core at the base of the building carry larger axial force than the mid sides of the core. By introducing a perimeter tube consisting of closely spaced columns interconnected with beams, this concentration of the force in the core is relieved but the same behaviour is shifted to the perimeter tube. Since the lever arm between the perimeter column pairs (located on two parallel faces of the tube) is large, the axial stresses induced in the columns are smaller than those induced in the core of the traditional frame building.

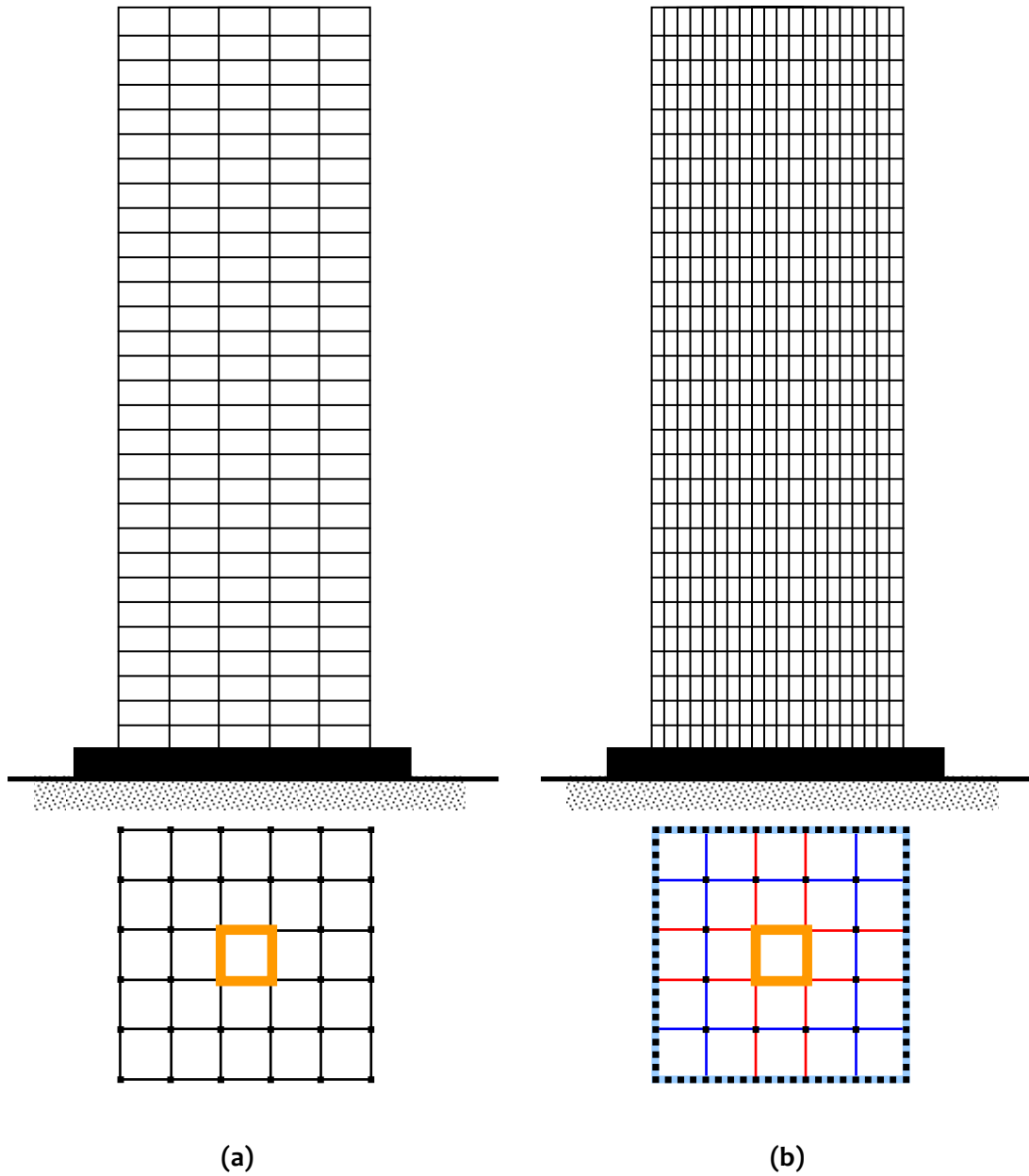


Figure 3.55: Comparison of Structural Systems: (a) Traditional Frame System with a central core, and (b) Tube System

The *Structural Plan Density* (considering both columns and core walls) of the Traditional Frame Building is 6% and that of the Tube Building 9.48%. The share in the SPD is 75% of frame columns and 25% of core walls in the Traditional Frame Building, and 87% of frame columns and 13% of core walls in the Tube Building. Thus, the share of column members is more in the Tube Building. Linear static analyses of the two buildings show that

- (1) in the Traditional Frame Building, columns take only 7% of the lateral shear as against core walls that take the remaining 93%; and
- (2) in the Tube Building, columns take *increased* 44% of the lateral shear as against the *reduced* remaining 56%.

Thus, increasing the structural plan density allowed more columns to be provided in the Tube Building. Even though the relative area share of the columns increased from 75% to 87% (*i.e.*, by about 12%) in the Tube Building, the share of the lateral shear increased significantly from 7% to 44% (*i.e.*, by about 37%). This shift of large shear from the inner core to the perimeter tube is attributed primarily to the different and more efficient structural system in the Tube Building.

Another important behavioural aspect of these two structural systems is the *shear lag effect* in column axial forces. Under the earthquake induced lateral inertia forces, the axial forces are expected to be uniform in *all* columns on the leeward face of the building. But, it is not so in normal buildings (Figure 3.57). There is difference in axial forces amongst columns on the leeward and on the windward faces; the corner columns have larger axial force than the interior columns. In addition, farther the spacing of columns, the larger is the difference in column axial forces. Thus, buildings with *traditional frame structural system* have larger shear lag effect than buildings with *tube structural system*. The earthquake induced lateral inertia force is carried most by the stiffer frames. In a tube system, the closely spaced columns makes the two perimeter planes of the tube stiffer in the direction of inertia force. Hence, the less stiff frames move more than these and thereby induce deformation in beams. The shear lag effect is attributed to inefficiency arising out of transverse deformation induced in beams due to this relative deformation in the frames in the direction of earthquake induced lateral forces.

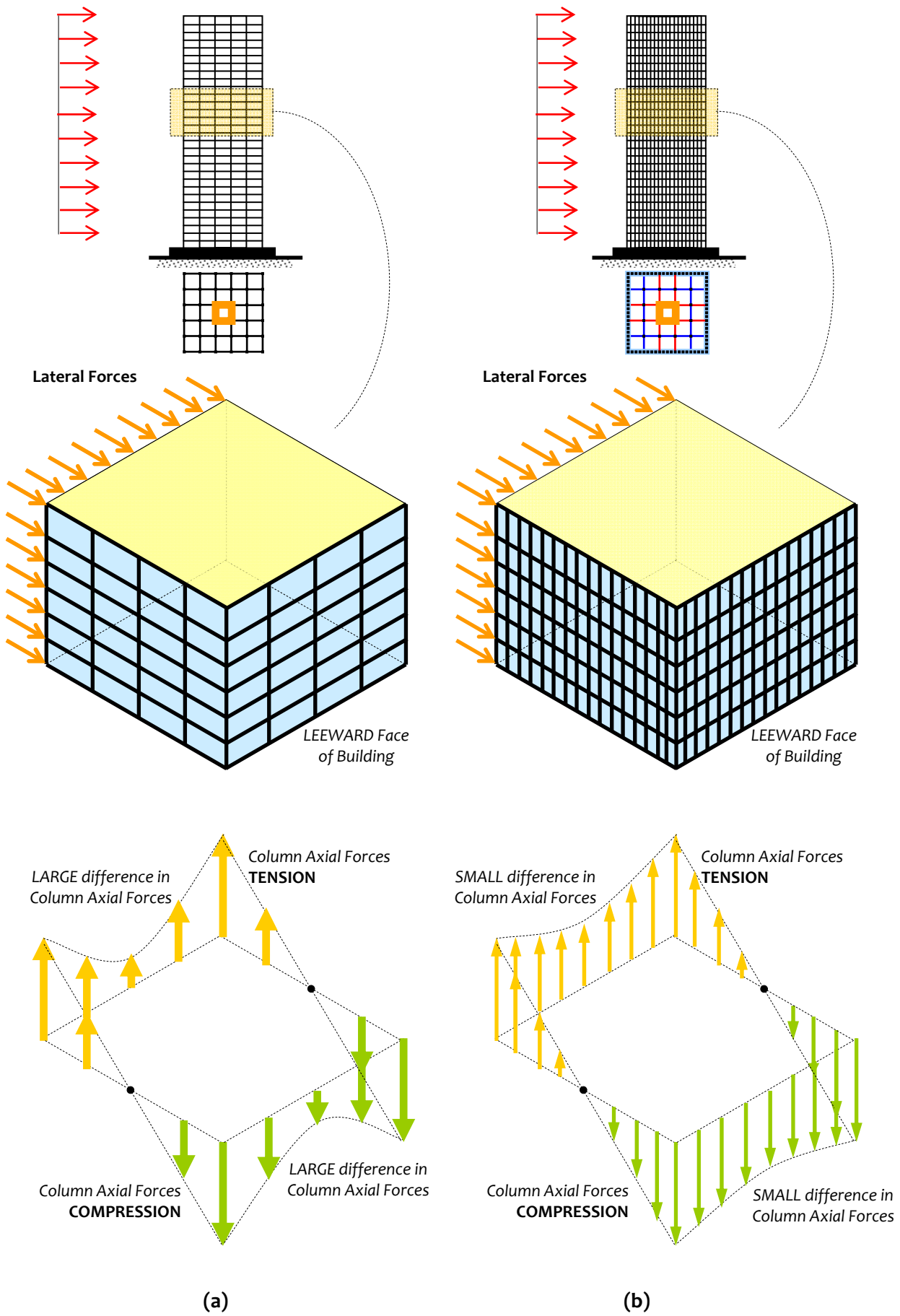


Figure 3.57: Shear Lag Effect in Structural Systems: (a) Traditional Frame System has large difference in column axial forces on leeward and windward faces, and (b) Tube System has small difference in column axial forces on leeward and windward faces

(e) Tube-in-Tube and Bundled Tube Systems

When the plan size of the building increases, additional columns may be required to support the gravity loads between the outer tube and inner core, and prevent the slab from bending too much. These columns are not part of the *main* lateral load resisting system, and therefore are not intended to carry any lateral loads; they are called *gravity columns*. When the building plan is large, sometimes, many columns may be required to support the gravity loads. Then, it may be beneficial to create a *second* tube of columns interconnected with beams *inside* the perimeter tube of columns interconnected with beams. This system is called the *Tube-in-Tube System* (Figure 3.58).

In the *Tube-in-Tube system*, the tubes should be tied together with a stiff and strong grid of beams. Depending on the total load to be transferred, the spacing of the gravity as well as main frame columns need to be adjusted – closely spaced columns with center-to-center spacing even up to 2m are used. This also helps in uniform distribution of forces to the perimeter tube columns. If the distance between the two tubes is large, intermediate *secondary* beams, along with additional gravity columns, may become necessary for effectively transferring lateral forces to the tubes (Figure 3.59); the additional gravity columns keep the intermediate beams from deflecting too much and thereby make them capable of transferring axial compression without much out-of-plane deformation. More uniform distribution of gravity forces is achieved with closely spaced beam grids between the tubes.

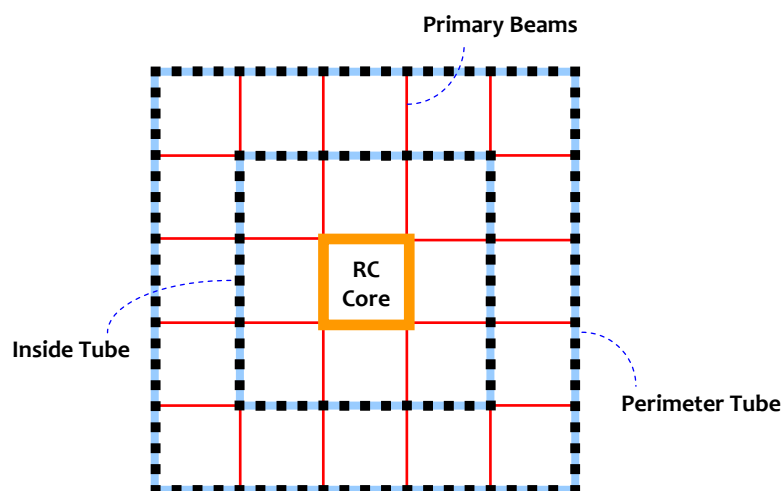


Figure 3.58: *Structural Elements in a Tube-in-Tube System:* Perimeter and inner tubes are connected with beams in line with the sides of the core and inner tube

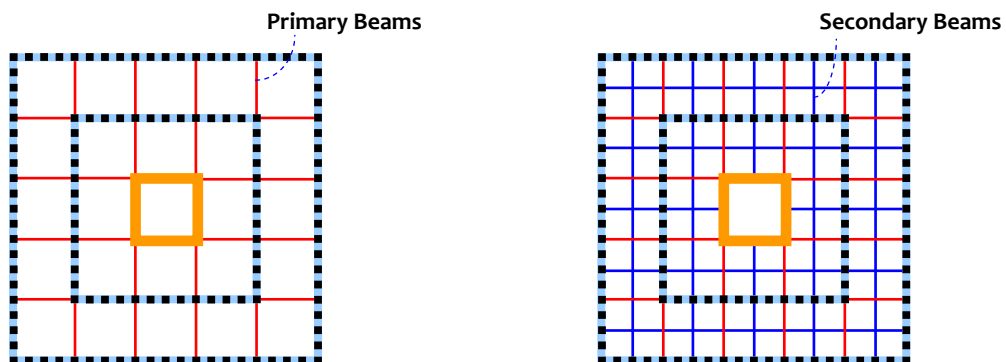


Figure 3.59: *Beams in Tube-in-Tube Systems:* Secondary beams help in transferring the gravity loads to the two tubes and the core

In large plan area buildings, when even the *Tube-in-Tube* system fails to control the lateral deformation of the building, an even *stiffer* lateral force resisting system is required. One system that can offer this is the *Bundled-Tubes System*; as the name goes, here a set of *Tube Systems* are stacked together to form the overall lateral load resisting system (Figure 3.60). The closely-spaced columns of the different tubes are placed in line to form an overall tube system. The RC cores of the tubes are connected to each other with beams that span directly between these stiff vertical elements; these beams are called *primary beams*. As in *Tube* and *Tube-in-Tube* Systems, additional gravity columns, secondary beams and tertiary beams may be employed when the span between the tubes and the cores are large, to improve the distribution of gravity loads to the tubes.

In the Bundled-Tube System, two major actions improve the lateral stiffness of the building and even reduces the demand on the closely spaced columns. These actions are:

- (1) Multiple tubes with many planes of large depths (in plan) of the closely spaced columns (almost making them act like walls of the full length); and
- (2) RC cores connected with stiff horizontal sub-systems at distinct levels along the height of the building.

The second action especially is absent in the *Tube* and *Tube-in-Tube* Systems. In *Tube-* and *Tube-in-Tube* Systems, connecting the inner and perimeter tubes with beams helps only marginally, because these beams are connecting both inner and perimeter tubes in their weak directions. Also, connecting the core with a perimeter or inner tube is helpful only marginally; again, this is because the tube is connected in its weak direction (Figure 3.61). The shear lag effect is much smaller in *Tube-in-Tube* System compared to that in *Tube* System (Figure 3.62).

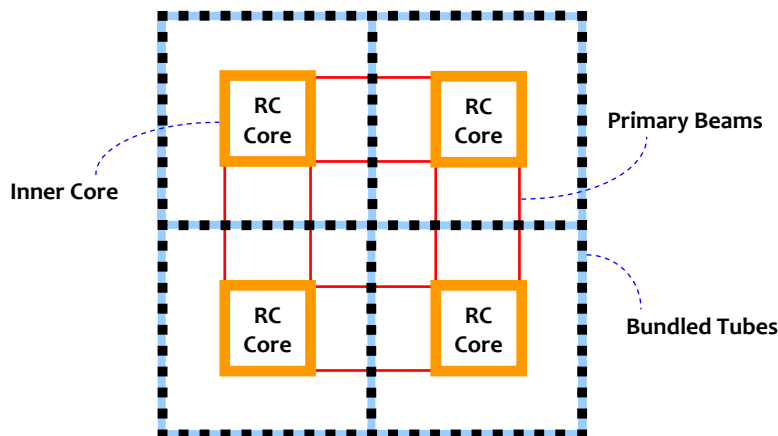


Figure 3.60: *Structural Elements in a Bundled-Tubes System:* Inner cores are connected with primary beams in line with the sides of the core

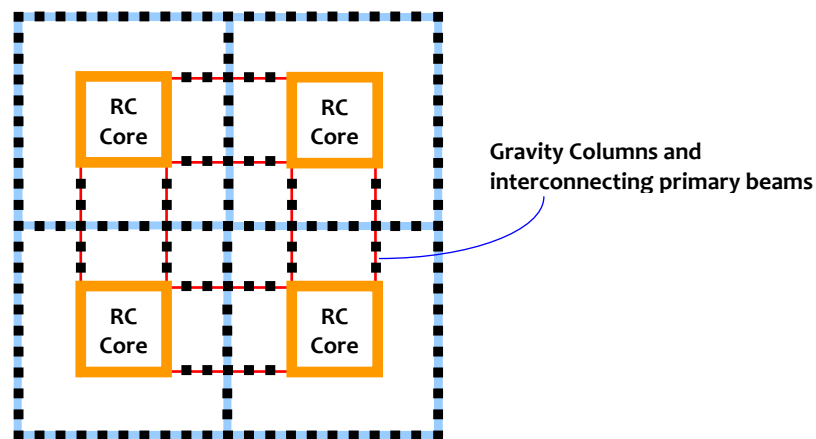


Figure 3.61: *Connection between RC Cores in a Bundled-Tubes System:* Gravity columns and interconnecting primary beams form the link between the stiff and strong RC cores inside the tubes

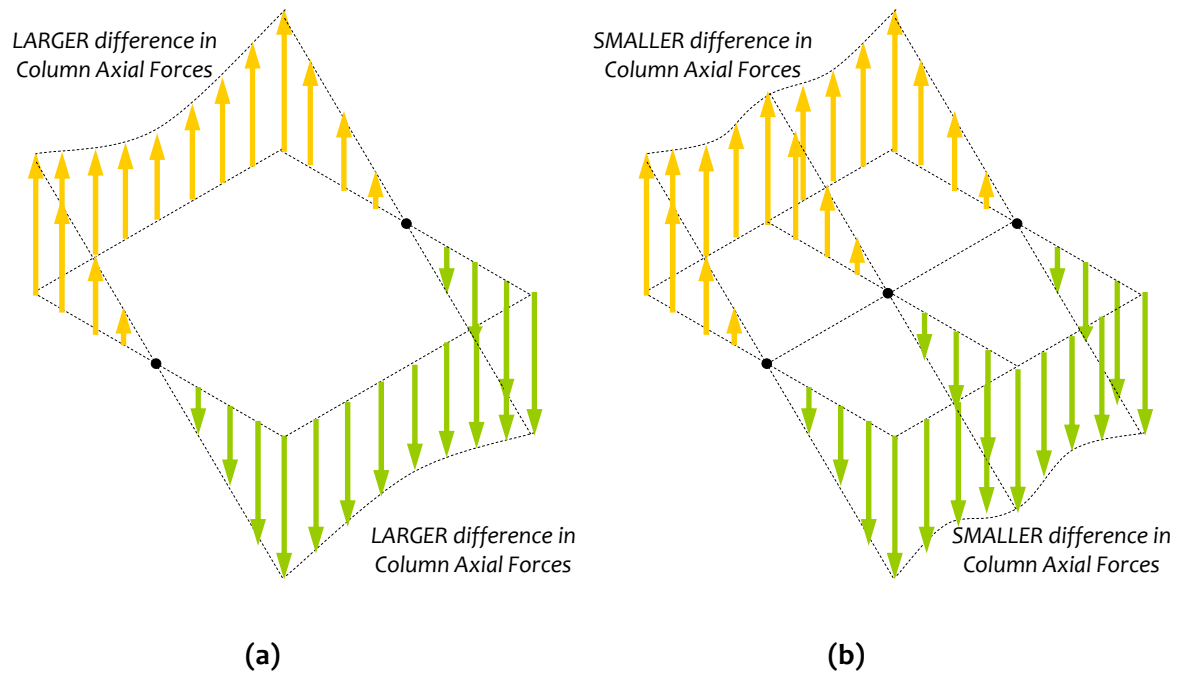


Figure 3.62: Shear Lag Effect in Structural Systems: (a) Tube System has large difference in column axial forces on leeward and windward faces, and (b) Tube-in-Tube System has small difference in column axial forces on leeward and windward faces

The importance of the second action is explained with the help of a simple planar frame of 40 storeys (each of 4m) and 12 bays wide (each of 4m). For the sake of simplicity, all columns, beams and slabs in the building are of the same size in all storeys in this example. Size of all columns in all storeys is 1000mm×1000mm, and that of all beams in all storeys is 600mm×800mm. The thickness of the walls is 1000mm. Two structural systems are considered, namely *Frame-Wall System with stiff wall of two bays at one end only of the frame* and *Frame-Wall System with stiff walls of two bays at both ends of the frame* (Tables 3.11 and 3.12). The two-bay wall represents the RC core. The moment frame members represents the gravity columns and beams interconnecting the RC core to the perimeter tube (in its weak direction) in the first structural system, and the two RC cores to each other in the second structural system. Both frames are subjected to the same lateral load; the distribution of this lateral force along the height is parabolic (as per IS:1893 (Part 1) – 2007).

There is practice of using *outrigger trusses* in tall buildings at single or multiple levels to control the lateral deformation of the building. The *outrigger truss* is a simple trusses spanning over the full height of that storey and across the full width of building (Figure 3.63). The role of the outrigger trusses is to make the columns act together in resisting overturning moments acting on the building. The pairs of columns generate couples of axial tension and axial compression to counter the overturning moments; this reduces the overall bending effects in columns. Five cases of connection between the RC core(s) are considered to demonstrate this numerically, namely

- (i) no stiff element at any level of the frame,
- (ii) outrigger truss at the top of the frame only with normal axial and flexural stiffness,
- (iii) outrigger truss at every ten storeys of the frame with normal axial and flexural stiffness,
- (iv) outrigger truss only at the top of the frame with large axial and flexural stiffness, and
- (v) outrigger truss at every ten storeys of the frame with large axial and flexural stiffness.

The deformed shapes, bending moment diagrams in frame members and principal stresses in the wall are shown in Tables 3.11 and 3.12. The following conclusions are drawn:

- (1) The presence of a stiff wall *on one side alone* does not help, even if the axial and flexural stiffness of the outrigger truss members are large. This confirms that using outrigger trusses in Tube and Tube-in-Tube Systems is not beneficial.
- (2) The presence of a stiff wall *on either side* helps immensely, especially when the axial and flexural stiffness of the outrigger truss members are large. This suggests that using outrigger trusses is beneficial in Bundled-Tube System.

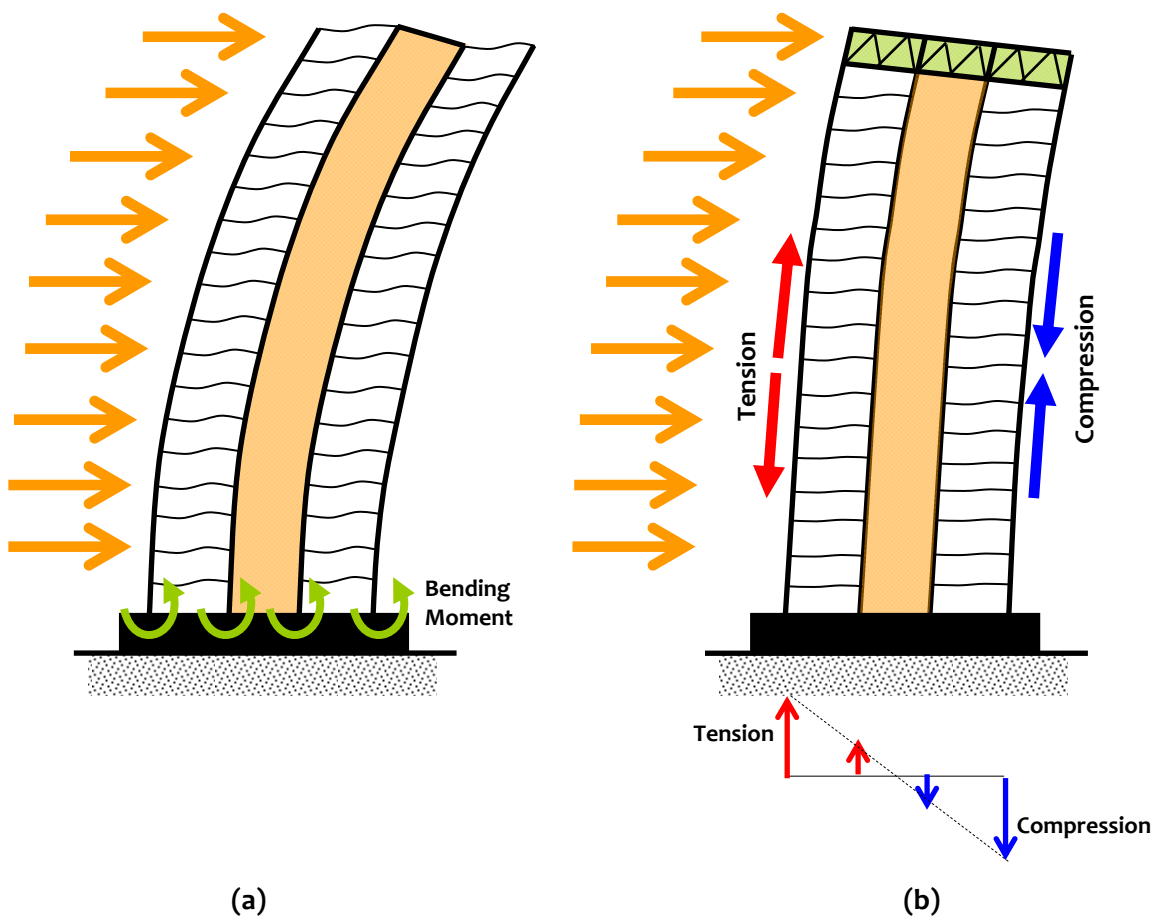


Figure 3.63: Outrigger trusses in Tall Buildings: Columns dominantly under effects of (a) bending moments, and (b) axial forces

Table 3.11: Performance of example 40-storey planar frame with a stiff wall at one end only

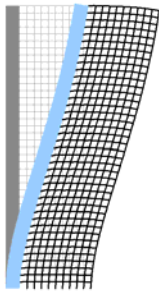

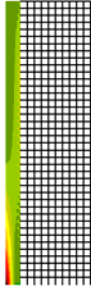
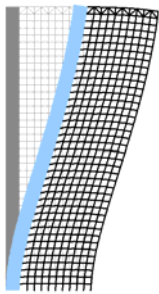

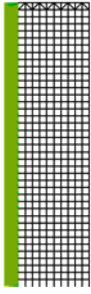
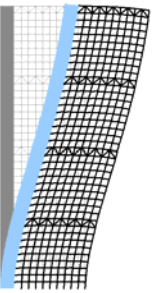

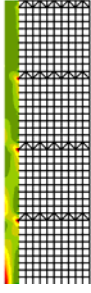
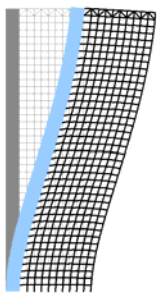

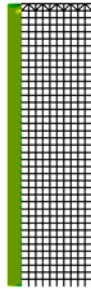
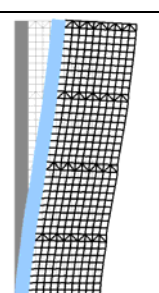
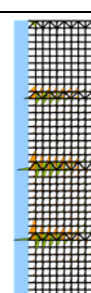
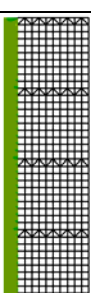
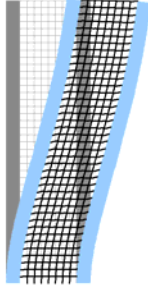

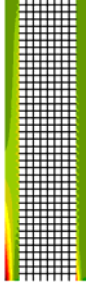
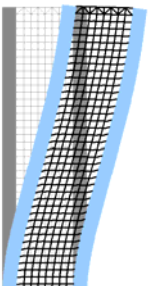

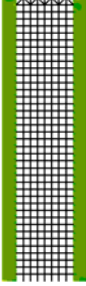
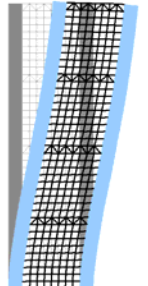
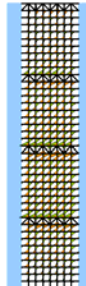
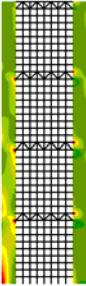
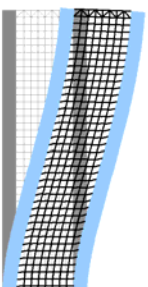

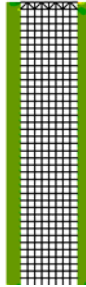
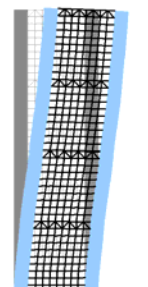

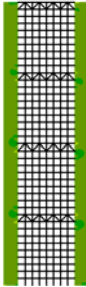
<i>Regular frame with</i>	<i>Deformed Shape</i>	<i>Bending Moment in Frame Members</i>	<i>Principal Stresses in Wall</i>
<ol style="list-style-type: none"> 1. Stiff core on left side 2. Perimeter tube on right side 	 <p style="text-align: center;">39 mm</p>		
<ol style="list-style-type: none"> 1. Stiff core on left side 2. Perimeter tube on right side 3. Outrigger truss connecting core and flexible direction of perimeter tube on right side ONLY at the top 	 <p style="text-align: center;">38 mm</p>		
<ol style="list-style-type: none"> 1. Stiff core on left side 2. Perimeter tube on right side 3. Outrigger truss connecting core and flexible direction of perimeter tube on right side at FOUR levels 	 <p style="text-align: center;">36 mm</p>		
<ol style="list-style-type: none"> 1. Stiff core on left side 2. Perimeter tube on right side 3. Extremely stiff outrigger truss connecting core and flexible direction of perimeter tube on right side ONLY at the top 	 <p style="text-align: center;">36 mm</p>		
<ol style="list-style-type: none"> 1. Stiff core on left side 2. Perimeter tube on right side 3. Extremely stiff outrigger truss connecting core and flexible direction of perimeter tube on right side at FOUR levels 	 <p style="text-align: center;">21 mm</p>		

Table 3.12: Performance of example 40-storey planar frame with stiff walls on both ends

Regular frame with	<i>Deformed Shape</i>	<i>Bending Moment in Frame Members</i>	<i>Principal Stresses in Wall</i>
1. Stiff core on both sides	 <p style="text-align: center;">35 mm</p>		
1. Stiff core on both sides 2. Outrigger truss connecting core and flexible direction of perimeter tube on right side ONLY at the top	 <p style="text-align: center;">34 mm</p>		
1. Stiff core on both sides 2. Outrigger truss connecting core and flexible direction of perimeter tube on right side at FOUR levels	 <p style="text-align: center;">24 mm</p>		
1. Stiff core on both sides 2. Extremely stiff outrigger truss connecting core and flexible direction of perimeter tube on right side ONLY at the top	 <p style="text-align: center;">33 mm</p>		
1. Stiff core on both sides 2. Extremely stiff outrigger truss connecting core and flexible direction of perimeter tube on right side at FOUR levels	 <p style="text-align: center;">17 mm</p>		

Six, 40-storey buildings are considered with same 40m×40m plan area. Two sets of columns spacing, namely of 2m and 4m center-to-center, are used for each of the three framing systems, namely *Tube*, *Tube-in-Tube* and *Bundled Tube* systems (Figure 3.64). The inner cores are made of reinforced concrete structural walls. The variations of axial force, shear force and bending moment along the height of the buildings are shown in Figure 3.65. The important observations made are

- (i) Bending moment and shear force in columns at corner of the buildings are small compared to those in columns in the middle of the buildings;
- (ii) Bending moment and shear force in columns are maximum not at the base of the building, but at height of 40-60 meters (*i.e.*, roughly about 1 to 1.5 times the base dimension) above the base (near the base, both bending moment and shear force in both corner and middle columns are significantly less compared to these maximum values);
- (iii) Axial force in the middle columns is negligibly small,
- (iv) There is significant increase in axial force in corner columns in all three structural systems near the base.

This is because the total lateral load on the building gets redirected as axial force towards the stiff corners of the buildings (Figure 3.56) near the base in line with the Poisson effect mentioned in item (ii) above. The actual values of forces in different systems depend on the size of beams, columns, and cores.

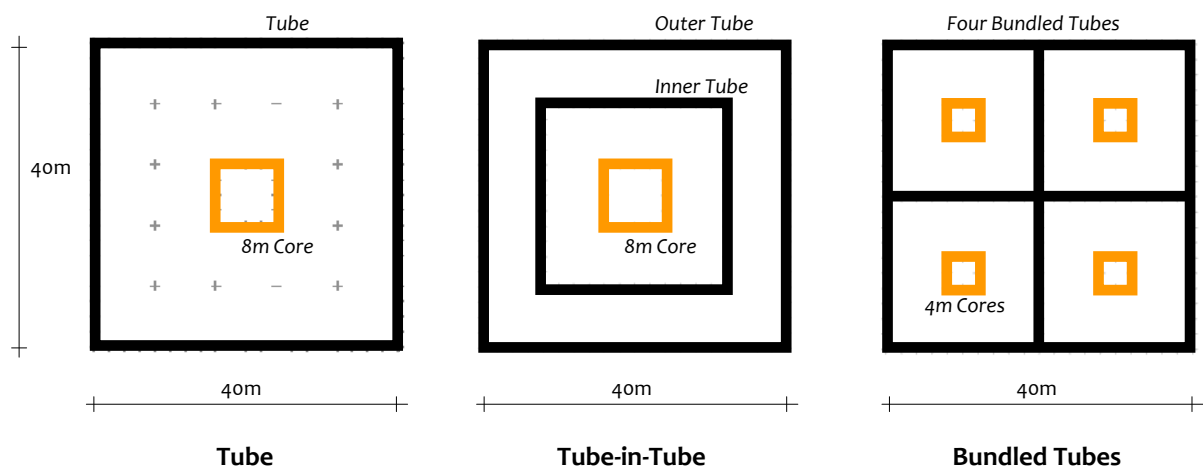


Figure 3.64: Comparison of Tube systems in tall buildings: Three basic types of tube systems used in practice are compared

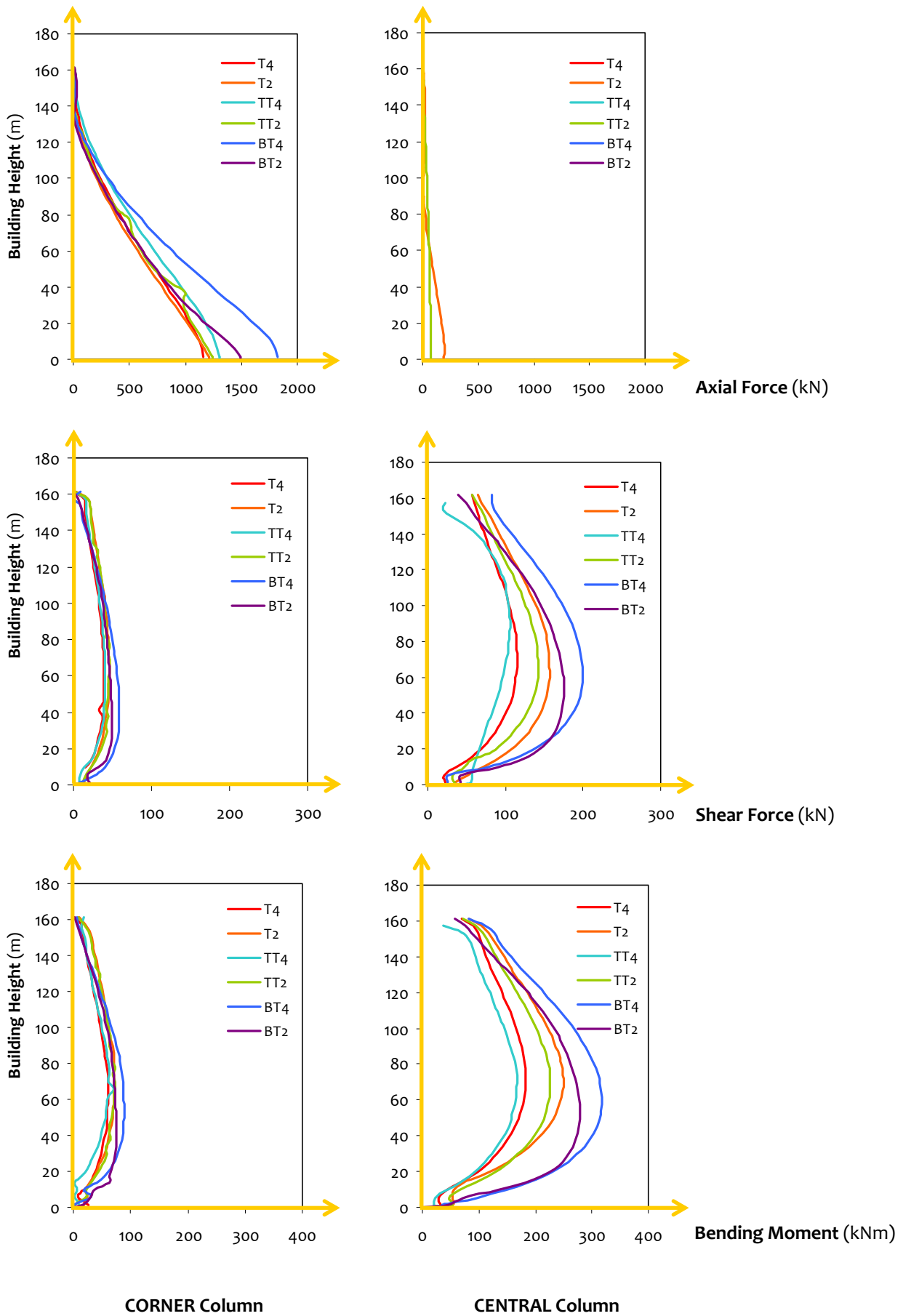


Figure 3.65: Variation of forces in Columns in the Tube (2m column spacing) along height of building: Force transfer in the lower storeys takes place largely through axial action in corner columns

(f) Flat Slab Building

A recent trend in building construction is to rest slabs directly on columns or walls (with or without drop panels) without employing any beams. This construction, commonly called *flat slab* construction, has become popular particularly in commercial buildings. Flat slab building has a *column-slab system*, which is expected to resist both *gravity loads* and *earthquake-induced lateral inertia loads*. Flat slab buildings have low lateral stiffness, and hence swing by large amounts elastically even during low level earthquake shaking owing to little/no rotational flexibility offered by the thin slabs inter-connecting the columns. Since the column-slab system has small lateral stiffness and lateral load resistance, this large overall lateral drift of the flat slab building makes the columns incapable of accommodating the additional secondary moments generated by the lateral deformations (Figure 3.66). Thus, there are serious concerns on the use of flat slab buildings in seismic regions.

Attempts were made to compensate for this lack of capacity in the slab in flat slab buildings by reducing overall lateral deformation and thereby to improve their overall lateral resistance by adding a supplemental *lateral load resisting system* (LLRS) in the form of structural walls. Consider two 5-storey buildings with flat slabs resting directly on columns in one, and on columns and structural walls at the edges on another (Figure 3.67). The buildings are subjected to gravity load and lateral load. The effect of adding supplemental lateral load resisting system is illustrated in Table 3.13 in terms of natural periods and lateral roof displacements in the two buildings; lateral drift is minimized by adding structural walls to flat slab buildings.

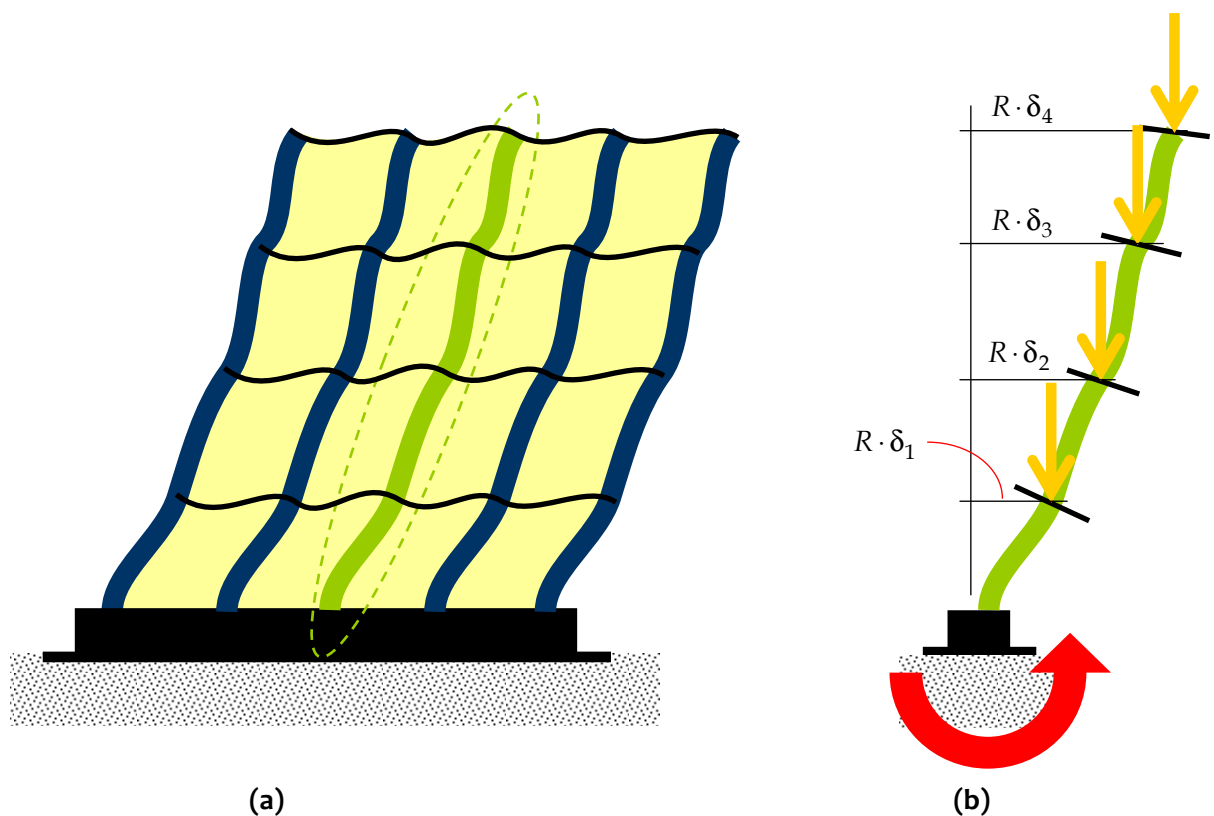


Figure 3.66: RC Flat slab building under lateral earthquake shaking: (a) Deformed building, and (b) Secondary moment at the base of the building

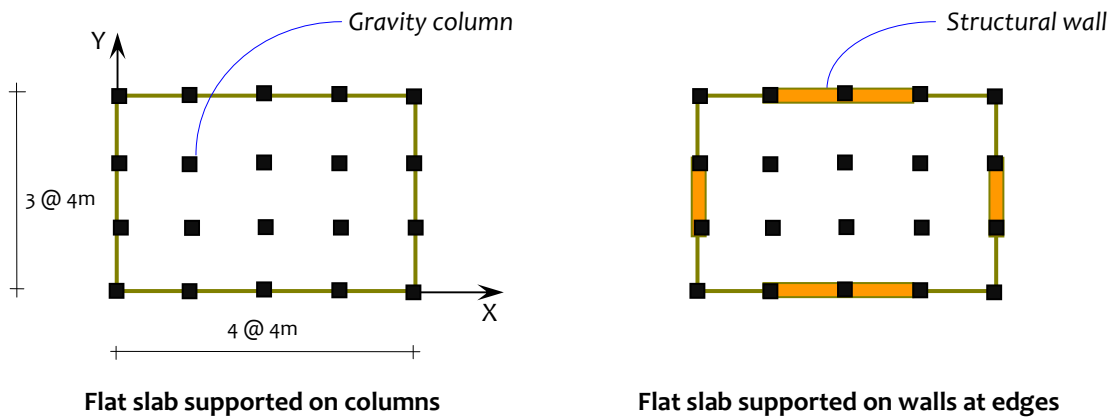
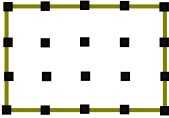



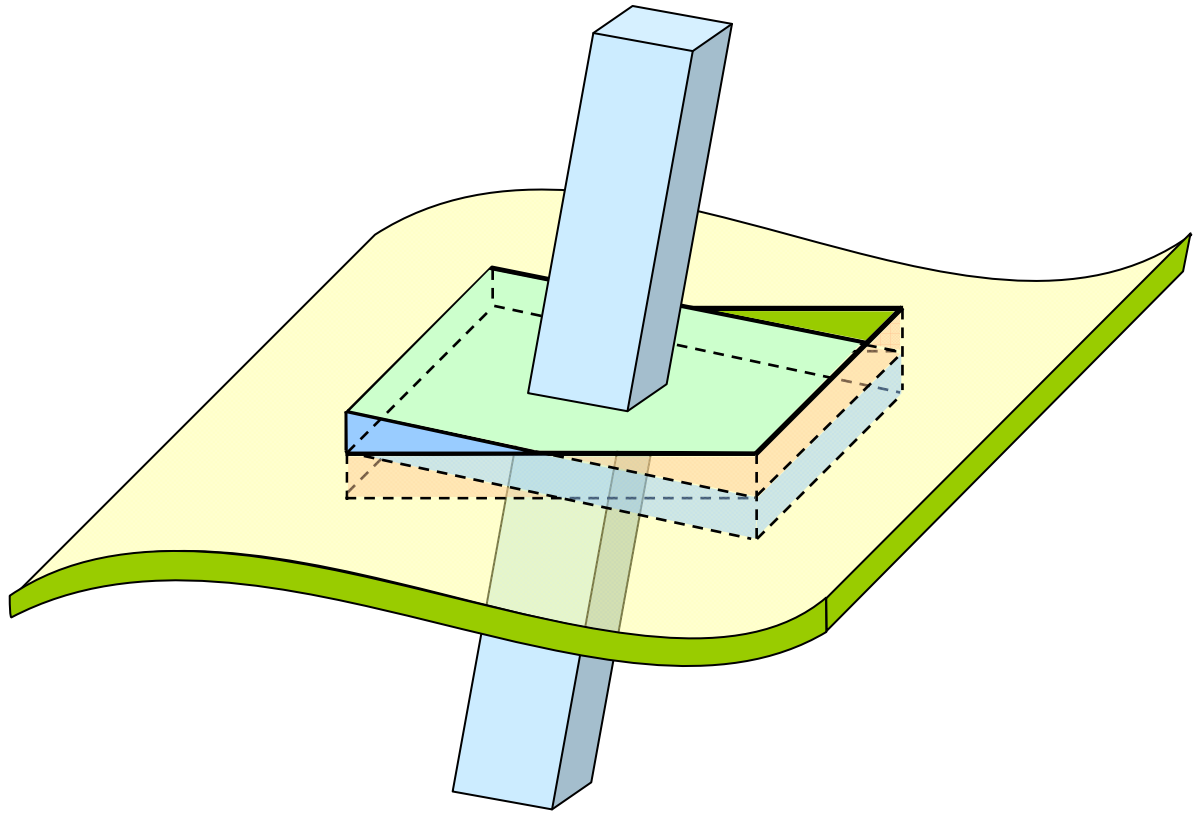
Figure 3.67: Flat slabs: Plan of buildings with flat slabs supported on columns and walls at edges

Table 3.13: Buildings with Flat Slabs: Flat slabs must not be supported on columns alone

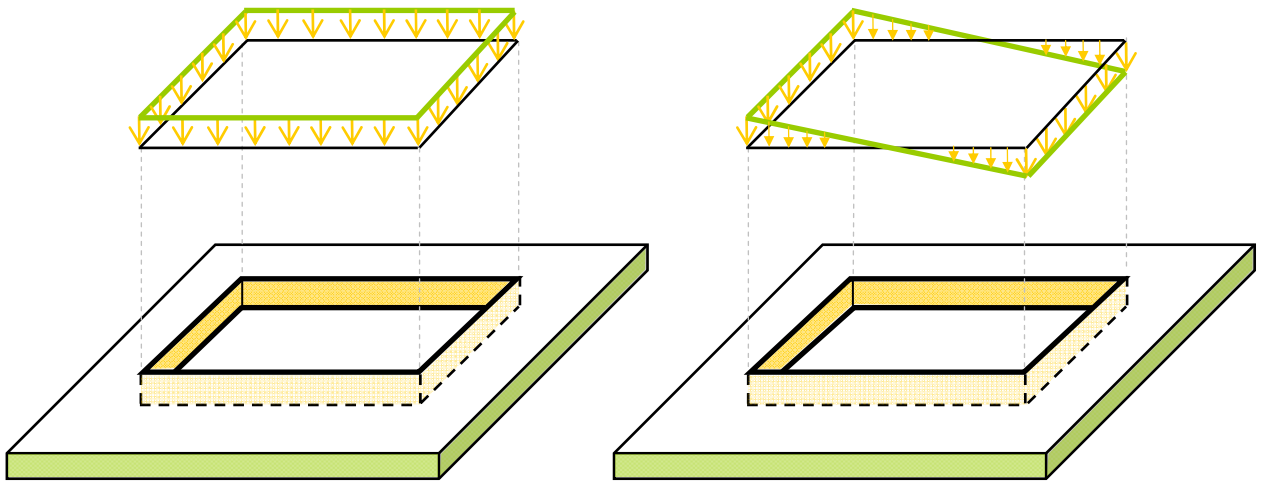
		
Mode 1	Y translation (1.07s)	X translation (0.42s)
Mode 2	X translation (0.97s)	Y translation (0.20s)
Mode 3	Torsion (0.76s)	Torsion (0.20s)
Roof displacement in Y direction	116 mm	24 mm
Roof displacement in X direction	96 mm	5 mm

In the design of flat slab buildings with additional LLRS (*i.e.*, structural walls), the walls were proportioned and designed to resist the *entire lateral load demand* on the building, while the *flat slab and column system* were designed to resist *only gravity loads*. During past earthquakes, failure of gravity columns highlighted that the *imposed lateral drift* on the columns were too large during seismic shaking, at which columns puncture through the flat slabs because the flat slabs are unable to maintain the deformation compatibility with the columns owing to unsymmetrical flexural shear generated at the column slab interface (Figure 3.68). With increase in lateral drift, this unsymmetrical flexural shear increases (Figure 3.69).

Under increasing levels of overall lateral drift on the building during seismic action, shear stresses in the flat slab increase (Figure 3.69). Even with the large lateral stiffness provided with supplemental lateral load resisting system (*i.e.*, structural wall) and the overall lateral drift of the building controlled, this unsymmetrical shear stress cannot be prevented from being generated owing to the displacement compatibility between structural wall and *flat slab – column system*. Hence, flat slab building with structural walls are at best suitable **ONLY** for *low seismic regions*. Some codes, *e.g.*, ACI 318, 2010, even prohibit the use of flat slab buildings in high seismic regions.



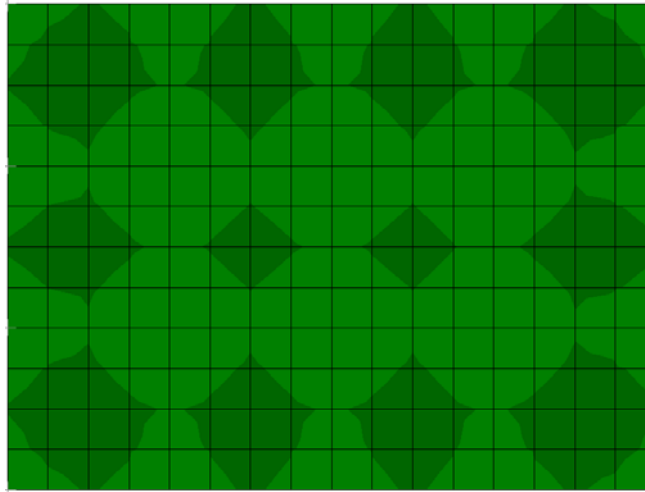
(a)



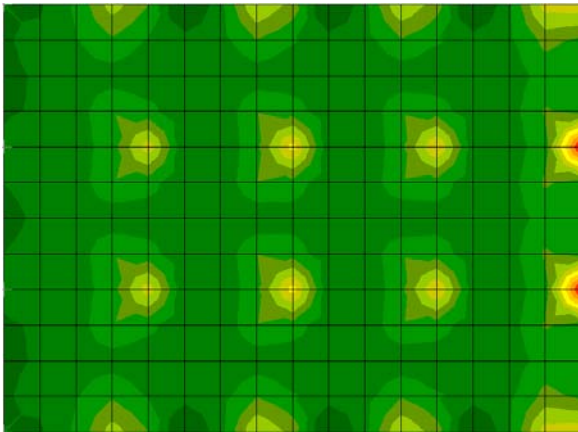
(b)

(c)

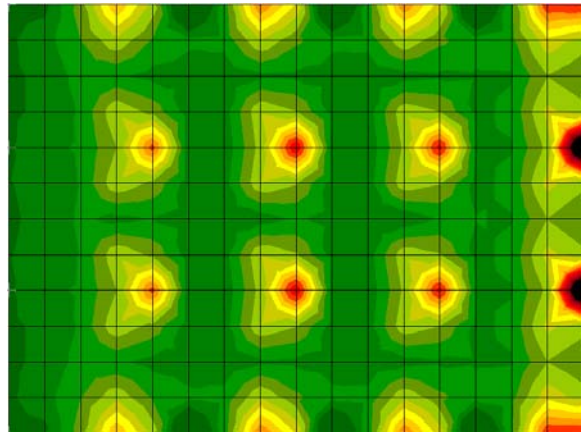
Figure 3.68: *Shear Stress at interface of RC Flat Slab and Column: (a) Symmetrical gravity shear, and (b) Unsymmetrical flexural shear*



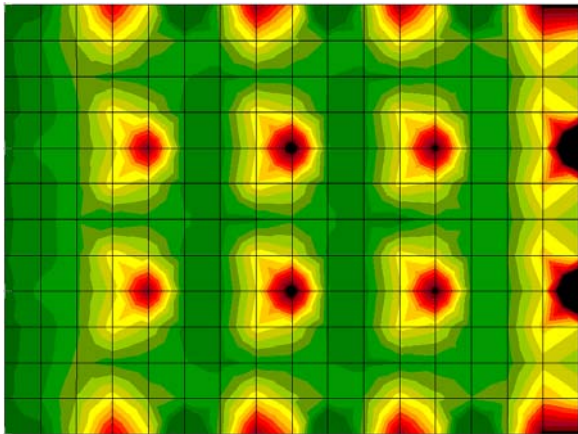
(a)



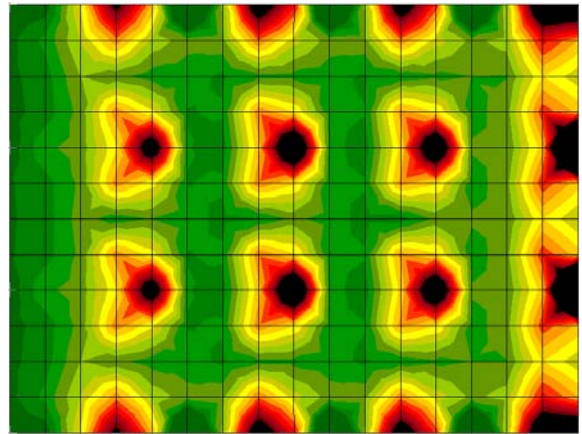
(b)



(c)



(d)



(e)

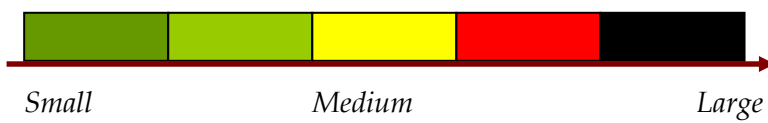


Figure 3.69: Unsymmetrical flexural shear stresses in flat slab of RC flat slab building: Dead load plus lateral drift in the building of (a) 0%, (b) 1%, (c) 2%, (d) 3%, and (d) 4%

3.2.3 Load Paths

Inertia forces mobilized in buildings during earthquake shaking travel towards the foundations. These forces travel through structural members, and thus, the choice and location of structural members greatly affect the seismic performance of buildings. A smooth path of least resistance needs to be provided for efficient transfer of forces up to the foundation.

Consider the original benchmark building along with different arrangement of braces in one, two and all three bays over the entire height of building in the Y-direction (Figure 3.70). Moment frames resist lateral loads through axial forces generated in columns, in addition to bending moment and shear force in both beams and columns. But, it is *easier* to transfer force through axial action than through flexural or shear actions. Thus, most of the loads travel through the braces (that are predominantly axial members) when available in a bay, instead of through beams and columns (that are predominantly flexural members). This is seen in Figure 3.71. This, in turn reduces bending moment and shear forces in the frame members in the bay. Also, X-braces are more effective than diagonal tension or compression braces (compare results of buildings B, C, and D). In building E, most of the forces are transferred through braces in the two end bays. But, in building F, all of the loads are transferred through axial actions in braces; bending moment and shear force are negligible in all members.

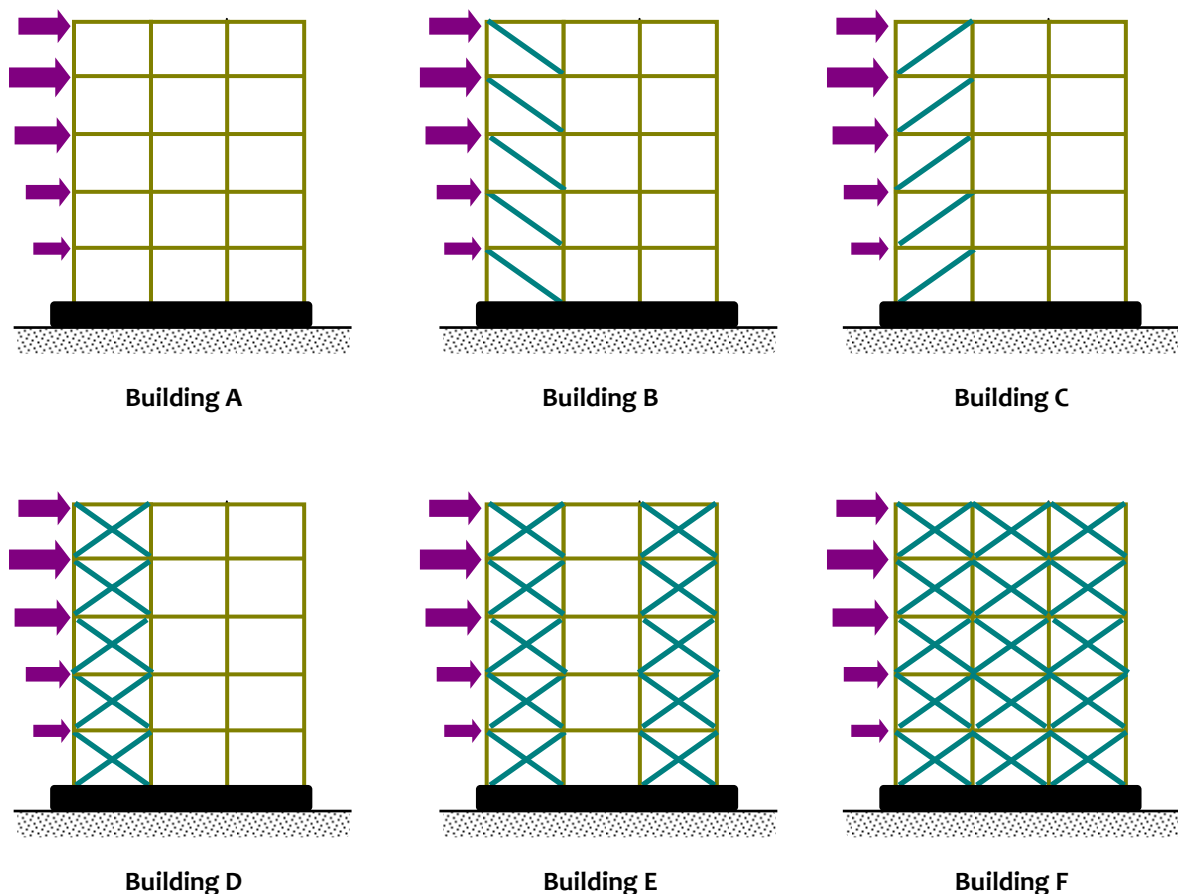
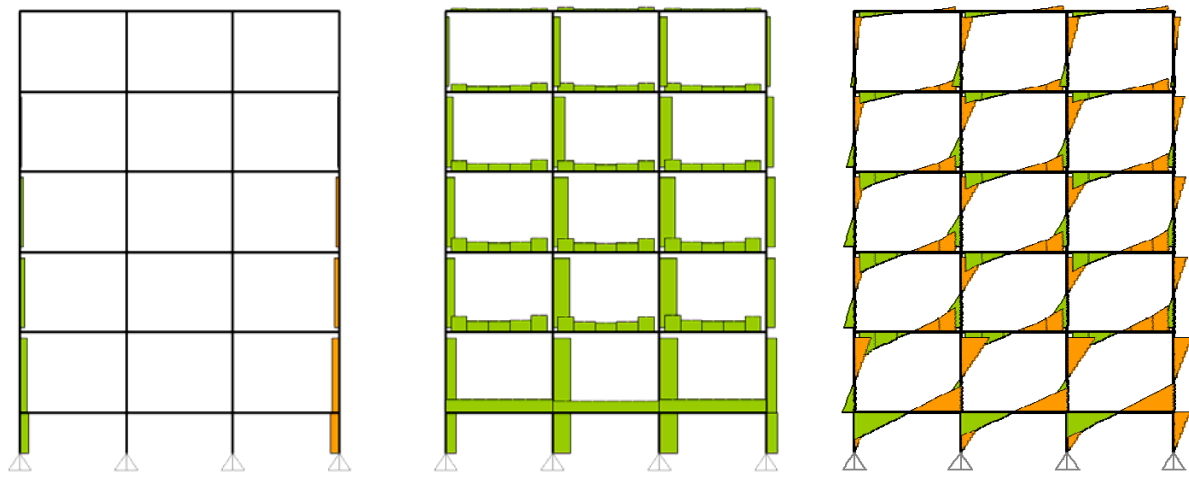
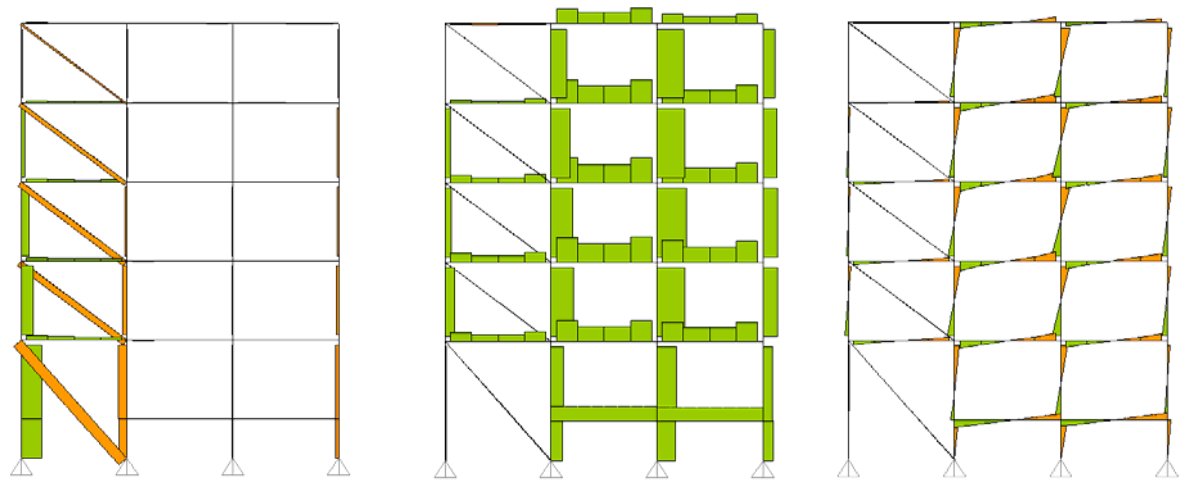


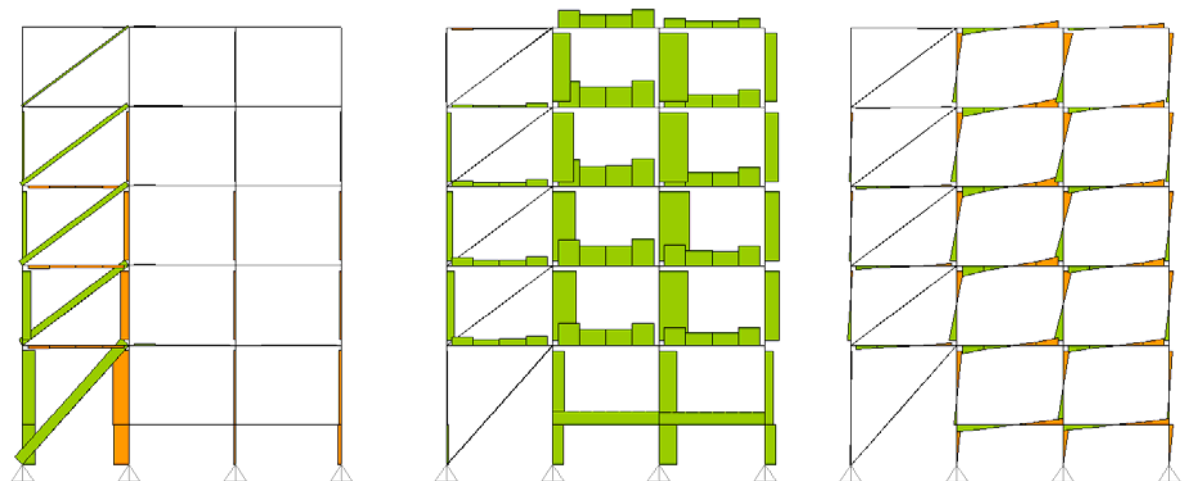
Figure 3.70: Braces offer direct load paths: Different load paths are possible based on the configuration of braces



Building A



Building B



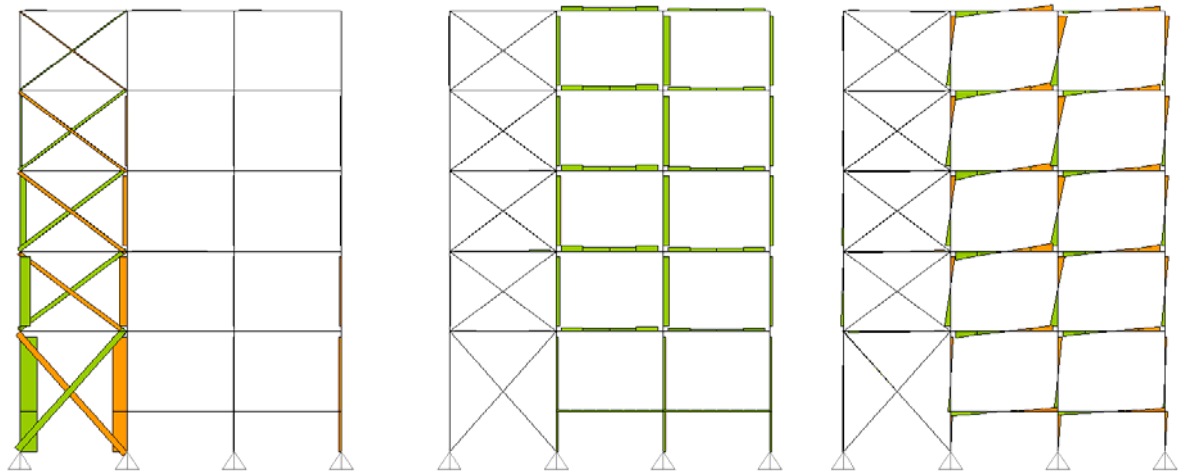
Building C

Axial Force

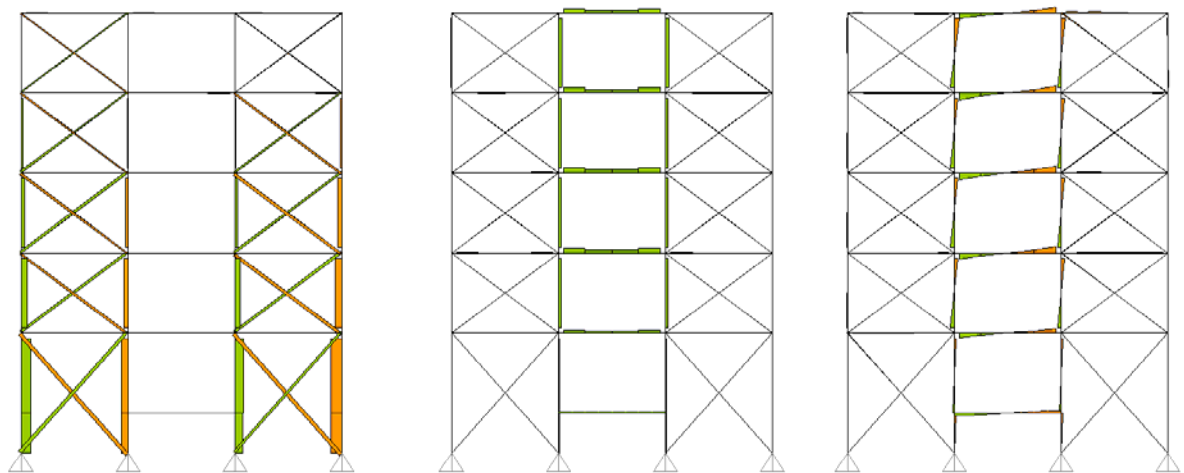
Shear Force

Bending Moment

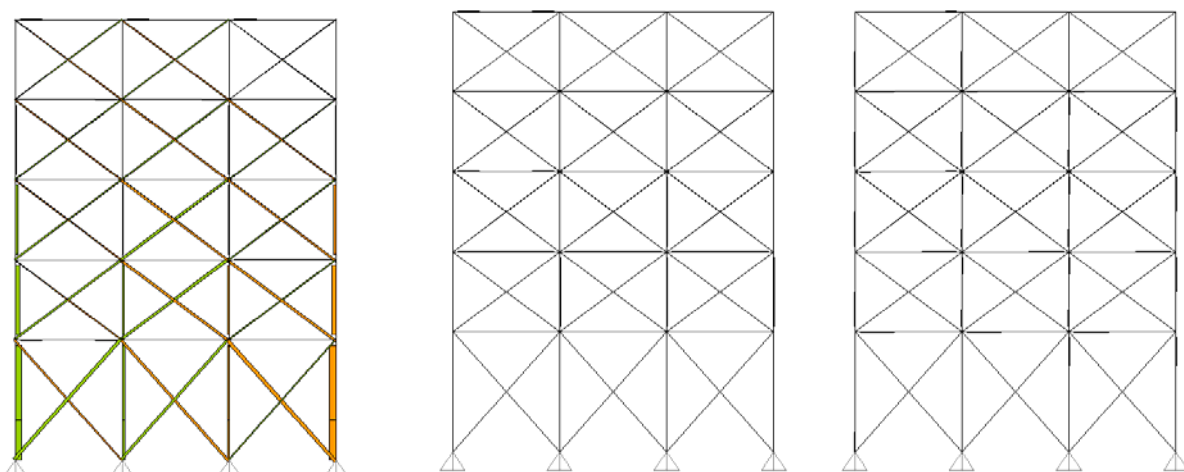
Figure 3.71: Different load paths in braced frames: Load transfer through axial actions in braces



Building D



Building E



Building F

Axial Force

Shear Force

Bending Moment

Figure 3.71 (Continued): Different load paths in braced frames: Load transfer through axial actions in braces

(a) Frames

A common form of discontinuity in load path in moment frames arises with a *floating columns*, i.e., when a column coming from top of the building is discontinued at a lower level, usually at the ground storey. In such cases, loads from the over hanging portions take a detour and travel to the nearest column that is continuous till the foundation. This leads to increased demand on the columns in the ground storey and can cause failure of these columns (Figure 3.72).

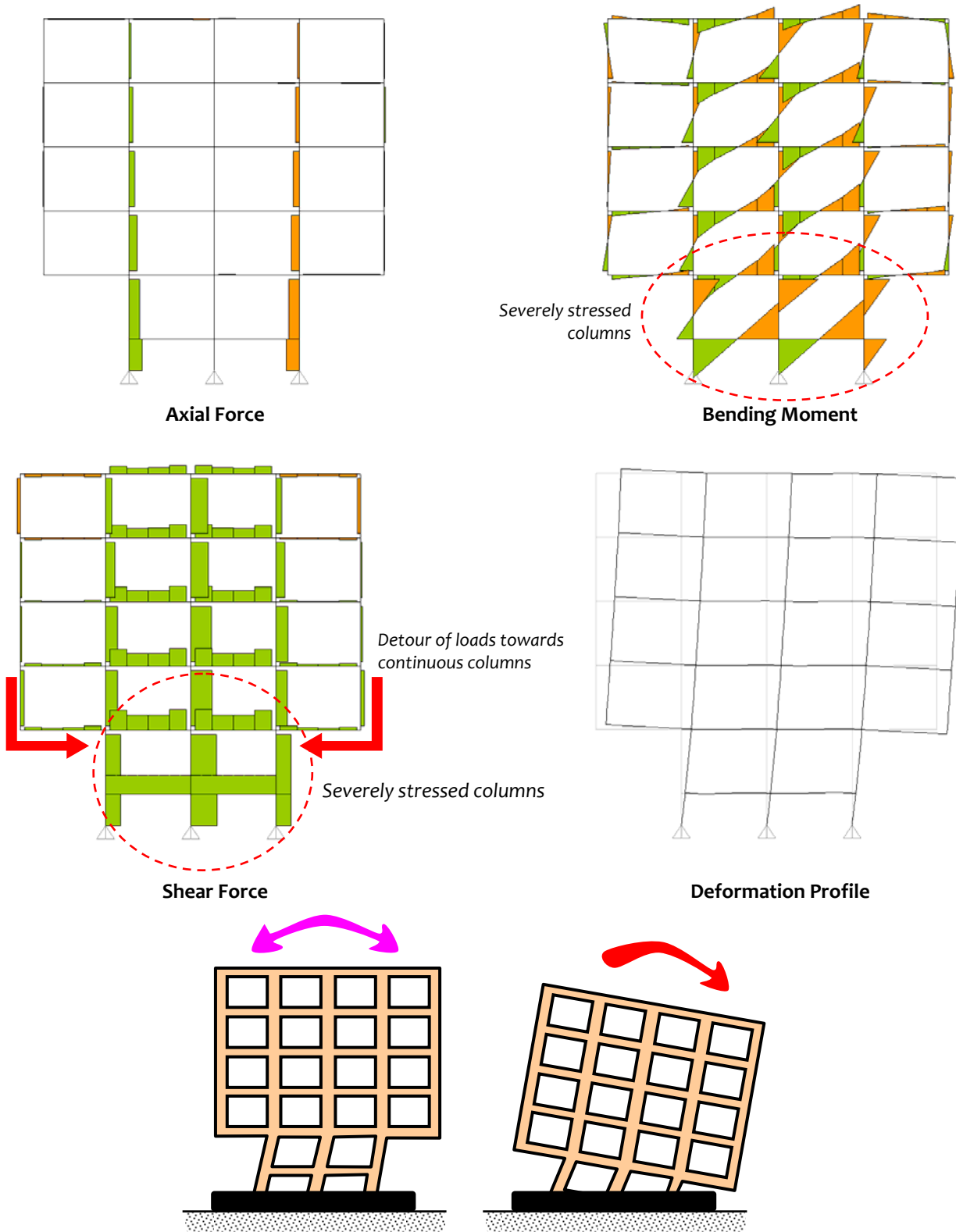


Figure 3.72: Buildings with floating columns: Overloading of columns in ground storey cause failure of buildings with floating columns during strong earthquake shaking

Another common discontinuity in load path in moment frames arises with *set-back columns*, *i.e.*, when a column coming from top of the building is moved away from its original line, again usually at the ground storey. In such cases, loads from the over hanging portions take detour and cause severe stress concentration at the re-entrant corners while traveling to the nearest set-back column. In addition, the set-back divides the span of beams into smaller segments, and thereby, pushes these beams into shear action (as against flexural action; Figure 3.36). These beams then draw large amount of shear force, and can fail in brittle shear mode. As a consequence, set-back columns subjected to large axial force, become vulnerable to combined axial-moment-shear failure (Figure 3.73).

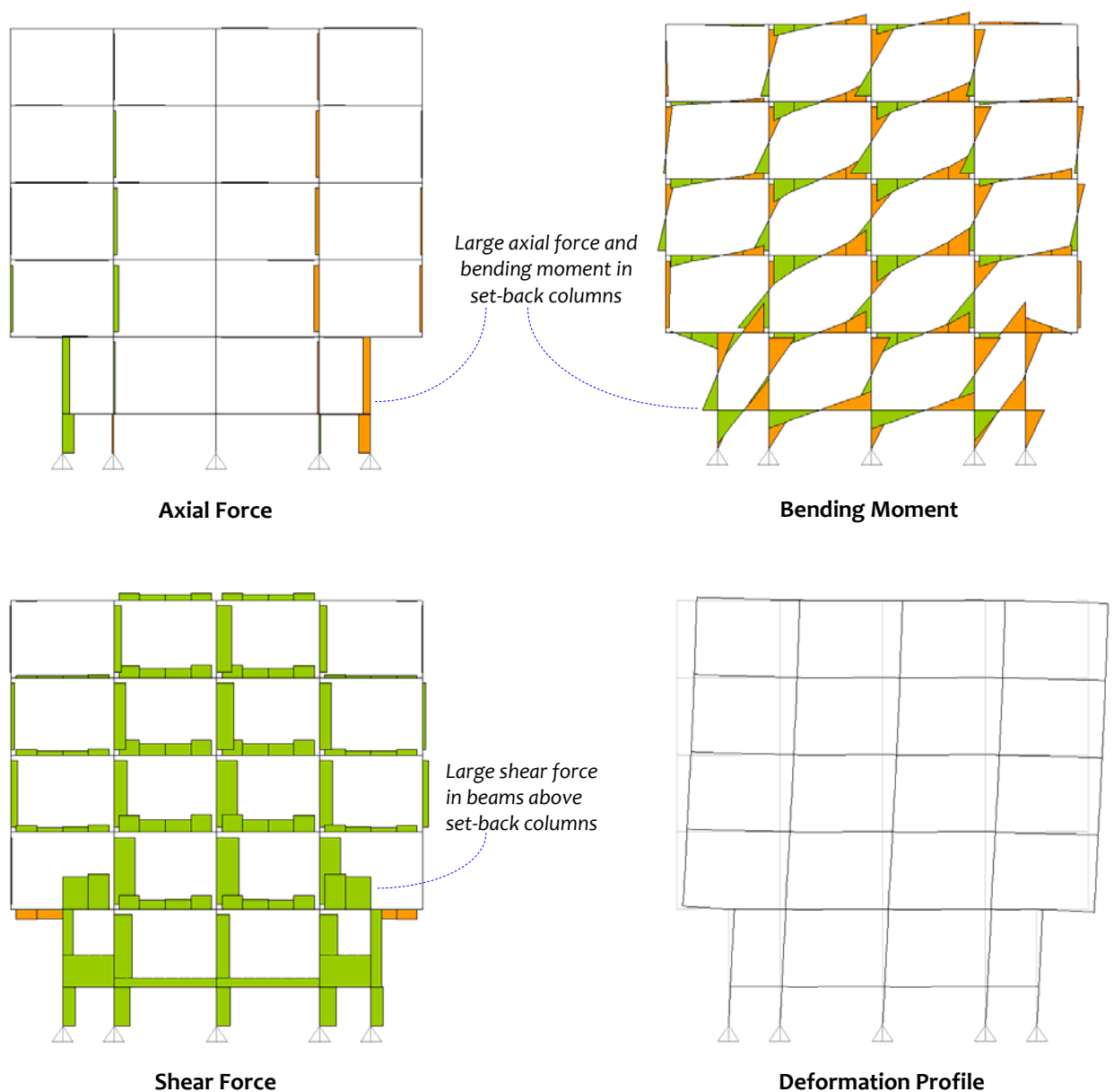


Figure 3.73: Buildings with set-back columns: Shear failure of beams above set-back columns is likely along with combined axial-flexural failure of set-back columns

While both floating columns and set-back columns pose discontinuity in load path in the vertical direction (in elevation), another common discontinuity of load path in the horizontal direction (in plan) occurs from *lack of grid* in the moment frame. Here, lateral load resisting columns are not aligned along a straight line in plan, but are inter-connected by beams that are at right angles to each other. Consider two possible plan layouts for a building for the same functionality requirement, but with different framing grids as shown in Figure 3.74. Building A has columns not aligned along straight lines due to functional requirements but building B has all columns placed along proper grid in both directions. Such lack of grid (as in Building A) causes (i) torsion of the building (the first two modes of oscillation are torsional followed by translation in Y direction), and (ii) increase in shear in short span beams and consequently increase in axial load on columns (Figure 3.75). This non-uniform distribution of loads to different structural members can initiate localized failures that in turn, can compromise the structural integrity of the building, or, even trigger global collapse of the building.

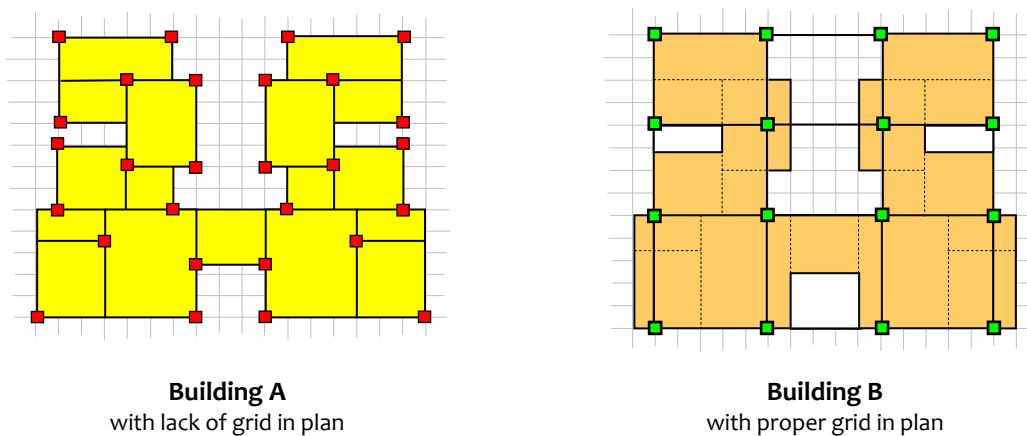


Figure 3.74: Buildings with lack of grid in plan: It is important to maintain proper grid in framing system

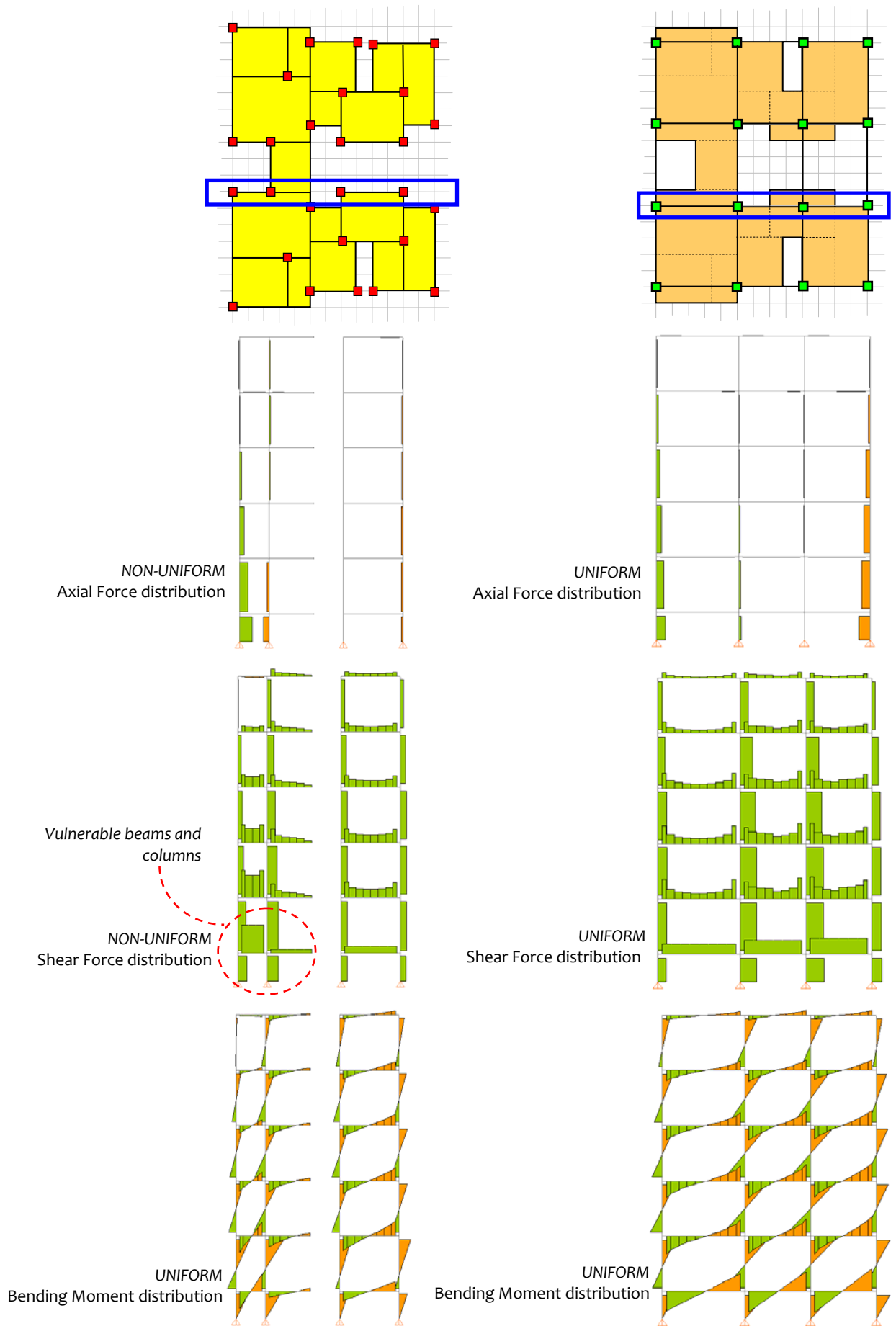


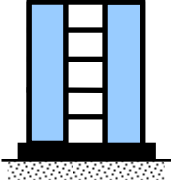
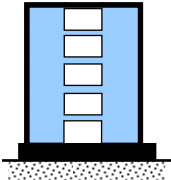
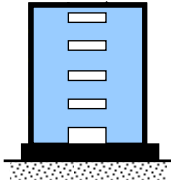
Figure 3.75: Buildings with lack of grid: Non-uniform distribution of forces can cause localized failures in members thereby affecting the structural integrity of the building

(b) Structural Walls

Discontinuity in load paths in buildings with Structural Walls occurs due to openings in the wall; openings are required for doors and windows. Structural walls carry significant lateral load and help reduce demands on regular frame members, *i.e.*, columns and beams (Figure 3.43). However, openings, particularly of large sizes, in these walls affect the load path and alter structural response of buildings.

Consider three levels of opening in coupled structural walls as shown in Figure 3.76. In building A, the middle bay is completely open and the beams are subjected to large moment demand at ends (particularly at the top), and the overall lateral deformation is large. Also, in such cases, the coupling beams should be designed to have enough ductility to accommodate the rotation demands (towards bending in double curvature) at ends. With reduction in opening, *i.e.*, with increase in depth of the coupling beams (as in building B), the overall lateral deformation is reduced, and the predominant action in the coupling beams changes from flexure to shear behaviour. In such cases, special diagonal reinforcements along with confining reinforcement are to be provided in the coupling beams to resist the shear (Figure 3.77). With very small openings (as in building C), the coupling beams form a part of the entire wall and more uniform distribution of stresses is obtained in the wall. The natural period and lateral deformation in the three buildings are listed in Table 3.14; lateral deformation is reduced with reduction in opening size; hence, large openings should not be provided in structural walls.

Table 3.14: *Shear walls with openings:* Large openings in shear walls increases flexibility of buildings

	 Building A	 Building B	 Building C
<i>Natural Period</i>	0.38 s	0.30 s	0.19 s
<i>Lateral Deformation</i>	8.1 mm	4.4 mm	1.8 mm

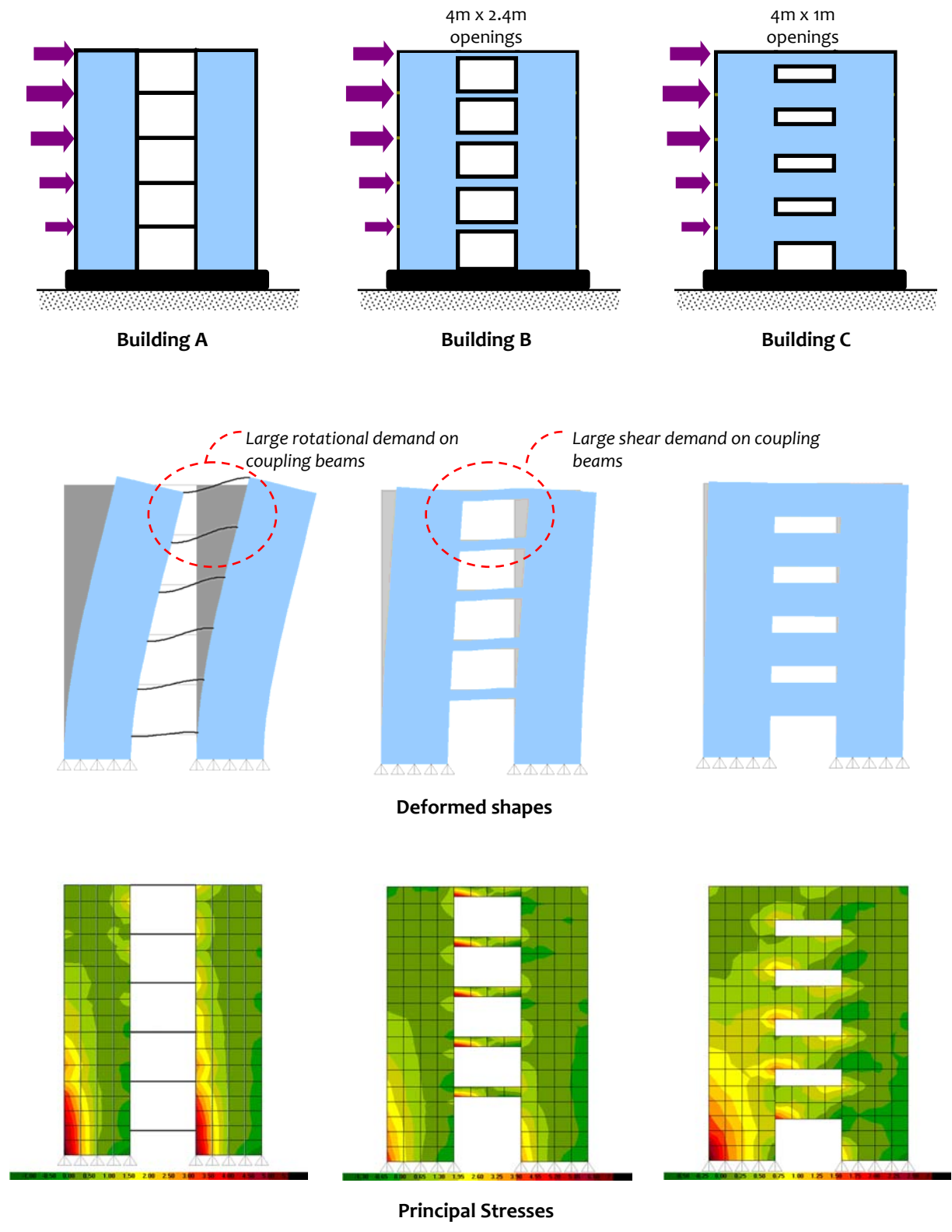


Figure 3.76: Shear walls with openings: Large openings in shear walls should be avoided

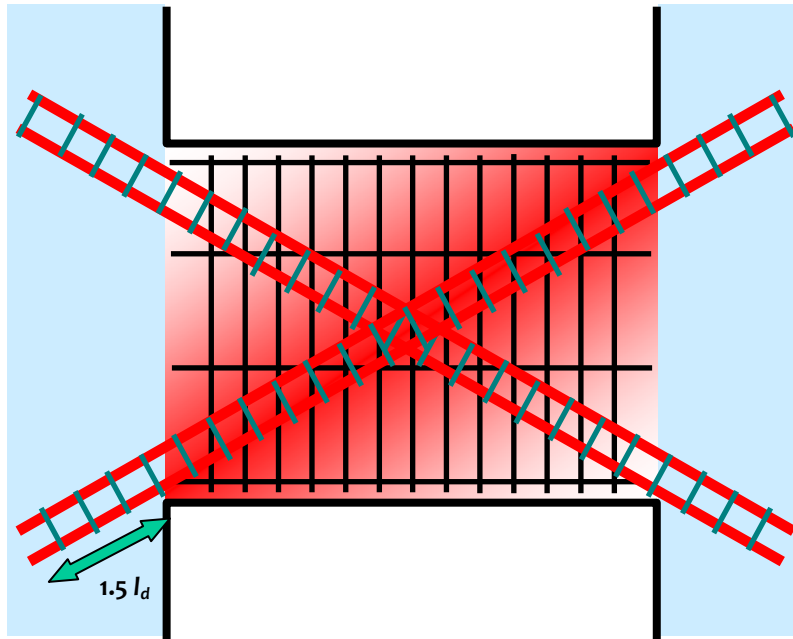


Figure 3.77: *Shear walls with openings:* Special diagonal reinforcement along with confining reinforcement to be provided in coupling beams

Structural walls are capable of resisting large lateral forces. Thus, it is prudent to provide walls along full height of buildings. However, sometimes these walls are not continued till the top; that causes distress to the top storeys. Consider the five-storey benchmark building with increasing height of structural wall in one bay in the Y direction as shown in Figure 3.78. Forces flow downwards through axial, shear and flexural actions in the frame members (*i.e.*, beams and columns) until they reach the structural wall. Thereafter, a large part of the load gets transferred through the structural wall thereby relieving demand on the beams and columns in the lower storeys, in which structural wall is present (Figure 3.79); the relative proportion of shear force is larger on the columns, when the structural wall is discontinued at a higher elevation. Stress contour on walls and floor slabs in the five buildings show more uniform distribution of stresses in the building with structural wall extending to the top of the building (Figure 3.80).

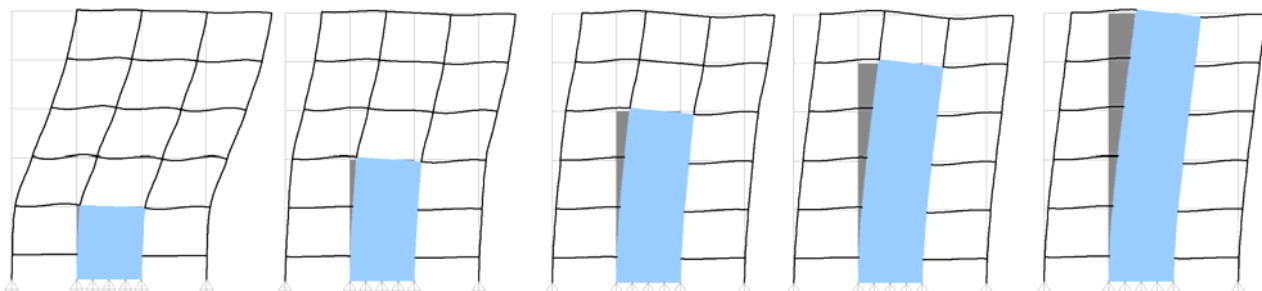


Figure 3.78: *Discontinuing structural wall in upper storeys:* Large deformation demand in storey immediately above structural wall

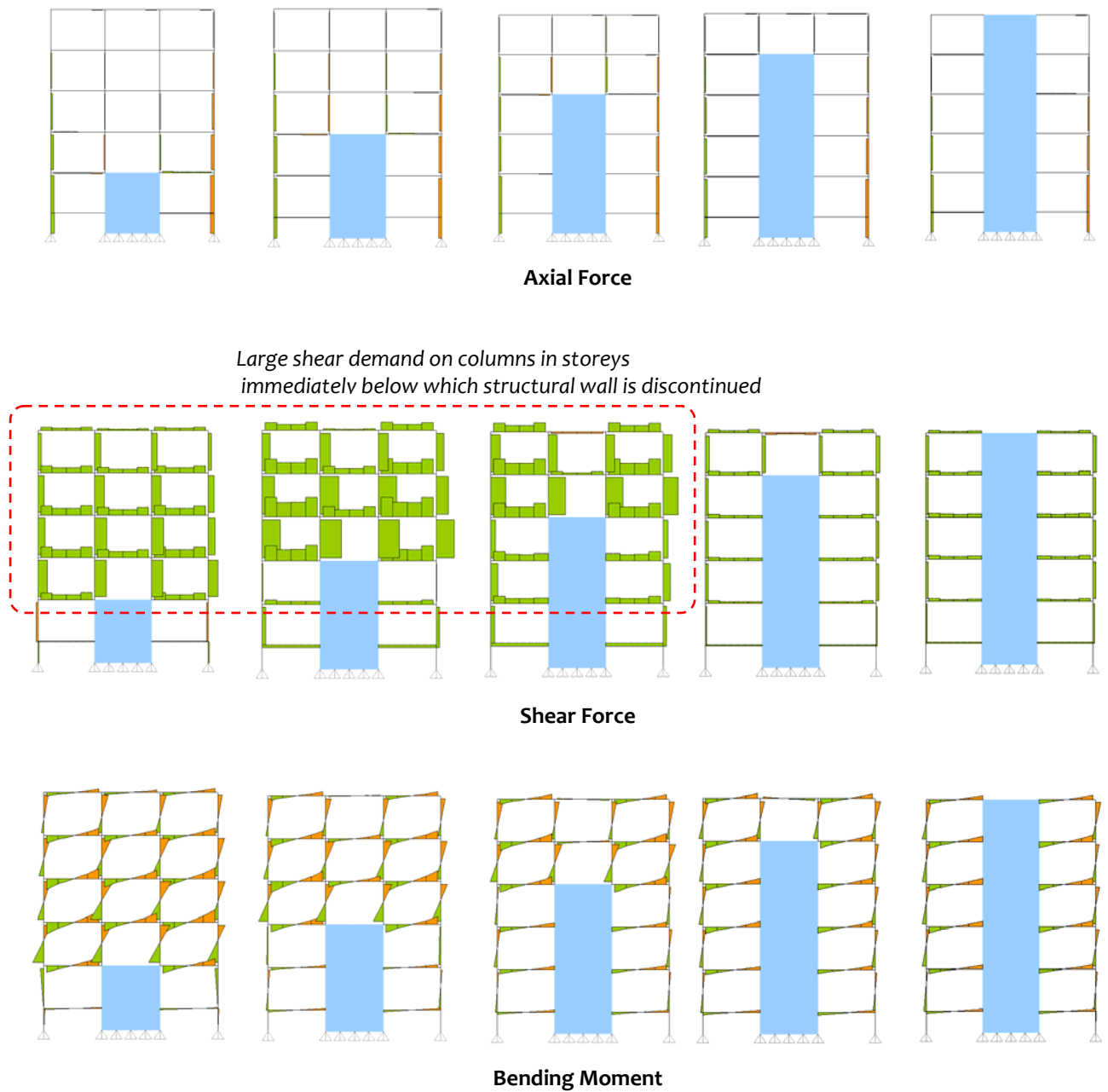


Figure 3.79: Discontinuation of structural wall in upper storeys: Significantly large demands are imposed on columns in upper storeys and can cause failure and collapse of the building

A more dangerous practice is to discontinue structural walls in lower storeys, particularly the ground storey. This causes serious disruption of load path; with the structural wall discontinued, loads now get transferred to the foundation as axial force, shear force and bending moment through the frame members. This causes large demands on the beams and columns in the lower storeys and can cause failure of these members (Figure 3.81). In particular, failure is likely of lower storey columns under combined action of axial force, bending moment and shear force.

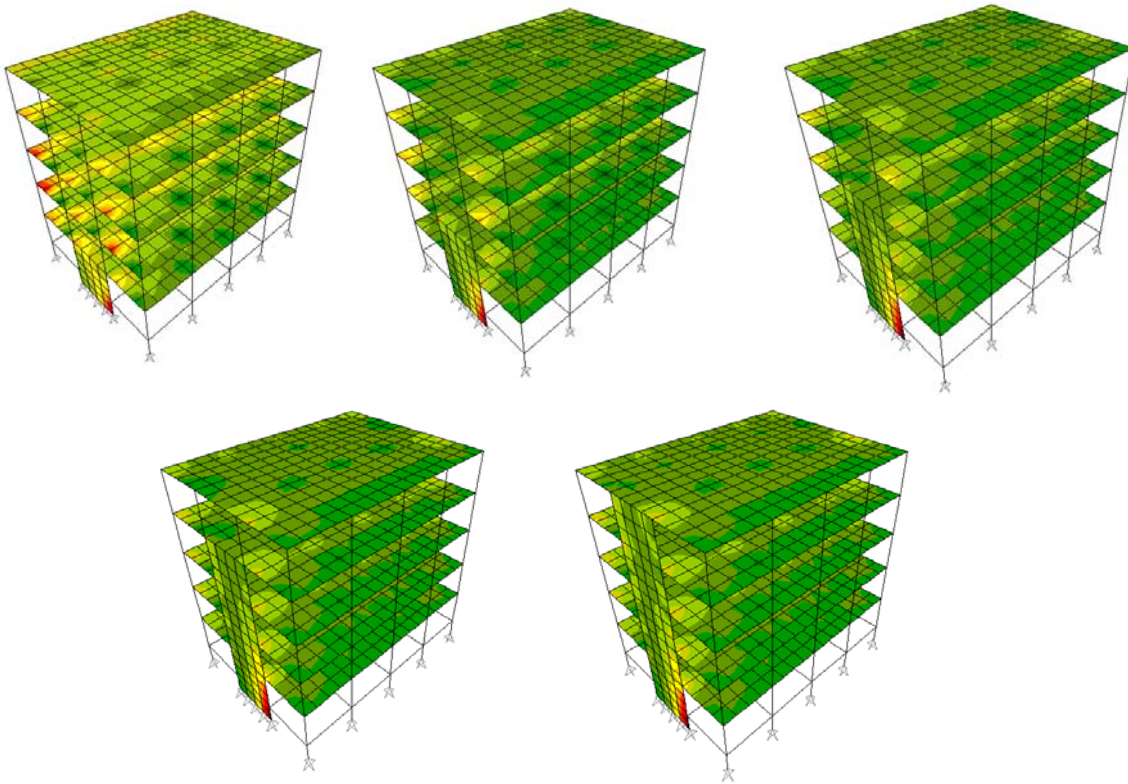


Figure 3.80: *Discontinuing structural wall in upper storeys:* Structural wall should be provided along the full height of the building

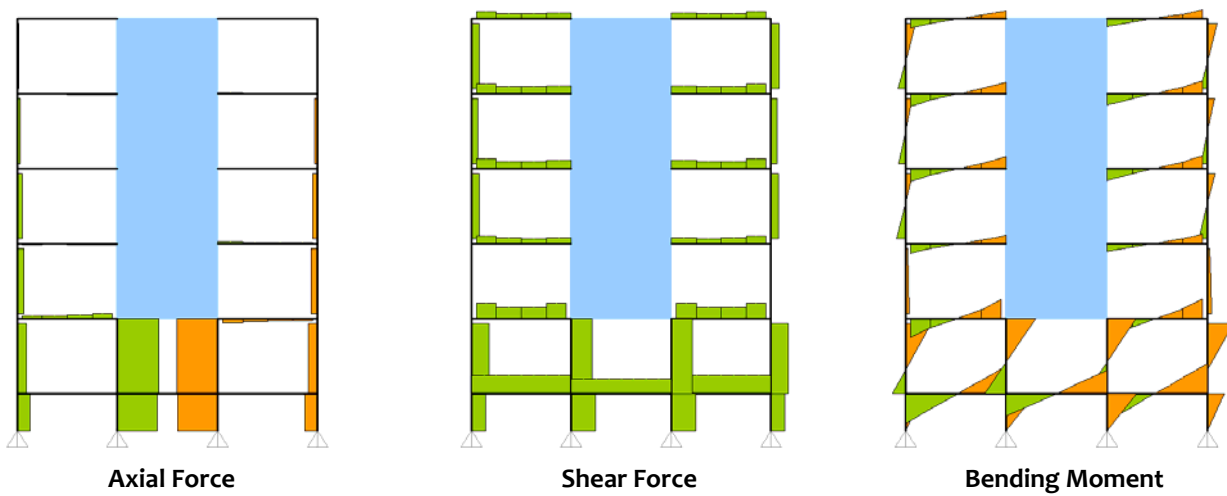


Figure 3.81: *Discontinuing structural wall at lower storeys:* Significantly large demands are imposed on columns in lower storeys and can cause failure and collapse of the building

Two more poor practices, again, are to discontinue structural walls in ground storeys but *provide* the discontinued part either in (i) the adjacent bay in the ground storey (causing in-plane discontinuity of structural wall), or (ii) in the adjacent frame in the ground storey (causing out-of-plane discontinuity of structural wall) (Figure 3.82). In both cases, the columns are subjected to large demands and may fail in the ground storey below the discontinued structural wall during strong earthquake shaking (Figure 3.83).

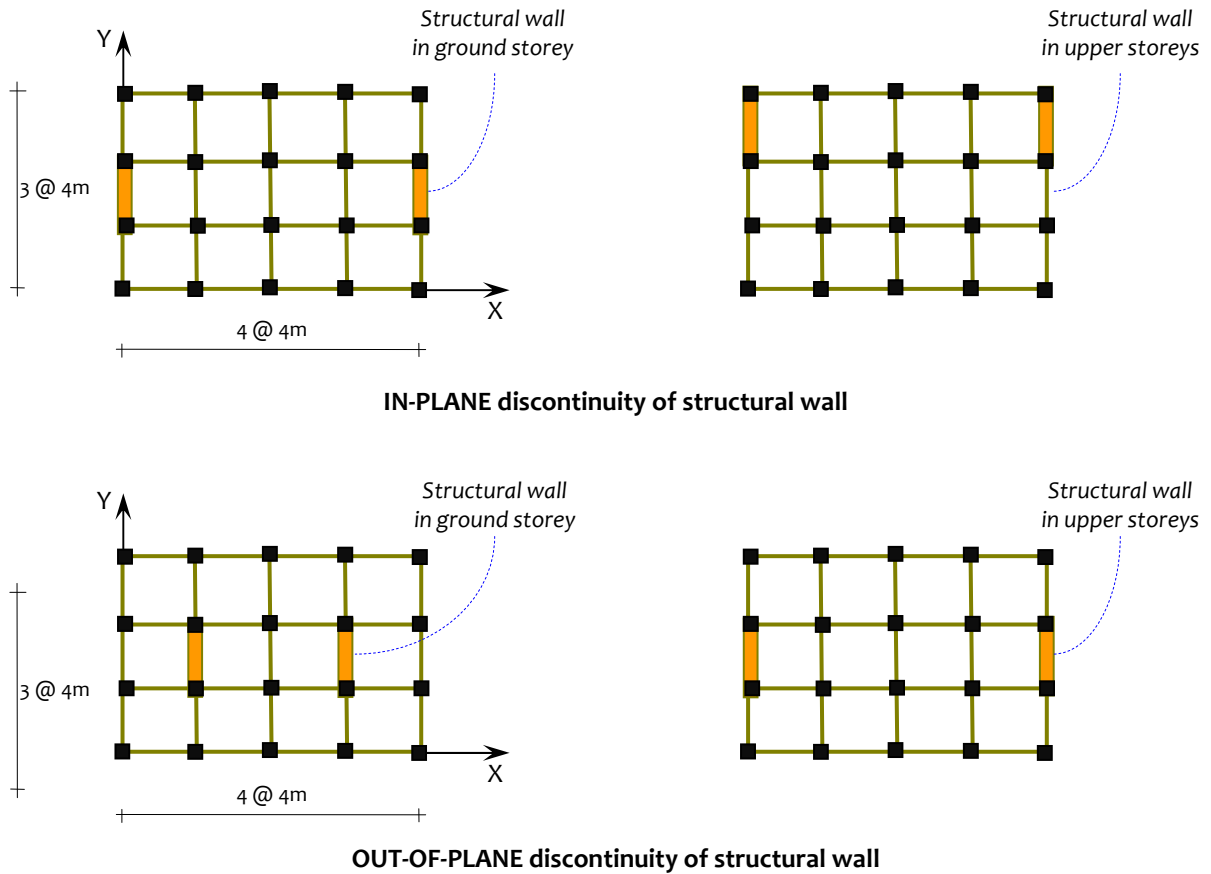


Figure 3.82: *Discontinuing structural wall in lower storeys: In-plane and out-of-plane discontinuity of structural walls*

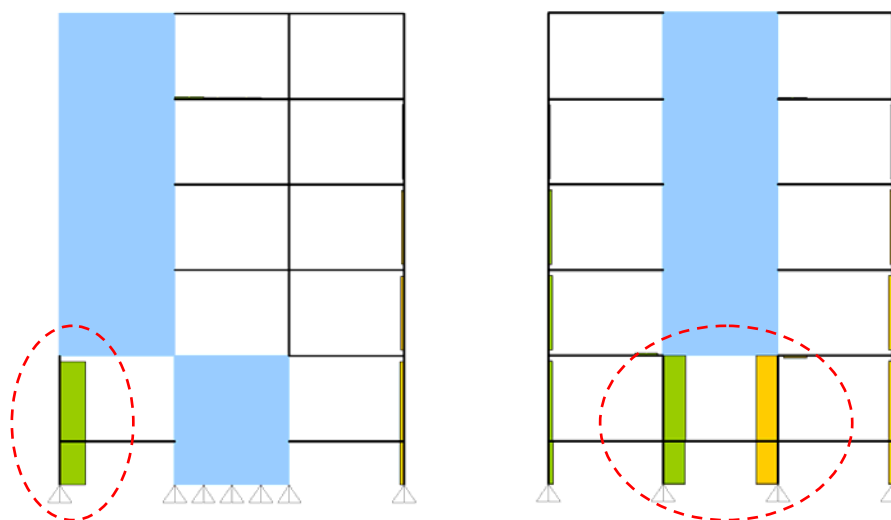


Figure 3.83: *Discontinuing structural wall in lower storeys: Large demand on columns in ground storey below discontinued structural walls*

3.3 MASS

Inertia forces are generated in buildings during earthquake shaking at locations where masses are present. For uniform distribution of forces in structural members, it is important to have inertia force mobilized uniformly in the building. For this, there should be uniform distribution of mass, both in plan and along the height of the building.

3.3.1 Mass Asymmetry in Plan

It is a common practice to have water tanks at roof top. But usually, water tanks with large mass of water are placed at corners of buildings. This affects the distribution of mass in plan, at least at the roof level. This asymmetry in mass in plan causes twisting of buildings during earthquake shaking due to mismatch of center of mass and center of rigidity (Figure 3.84).

Consider the benchmark building with an idealized heavy mass (8 ton) at one corner of the building as shown in Figure 3.85. The first three modes of oscillation of the building changes to translation in Y direction with twisting component, translation in X direction with twisting component, and pure torsion (Figure 3.86).

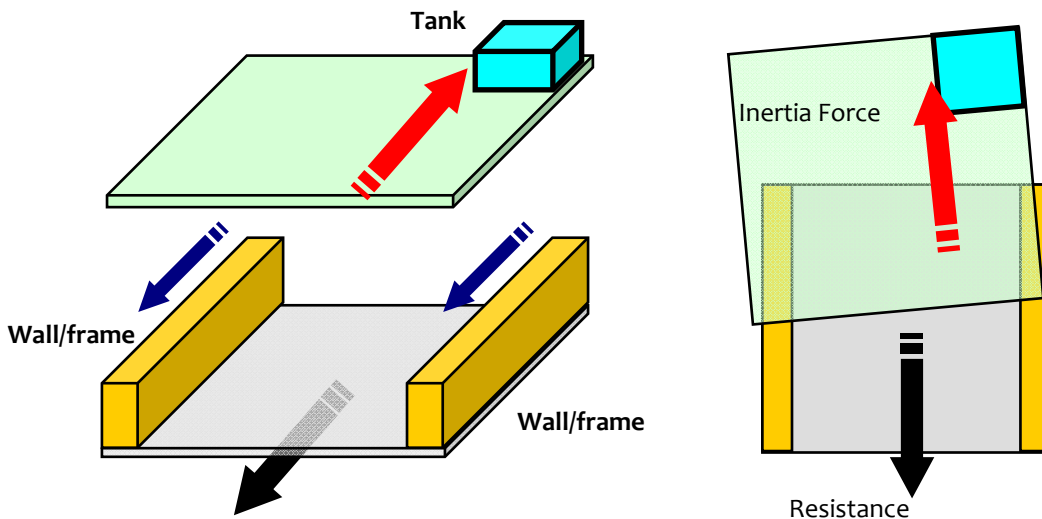


Figure 3.84: *Asymmetry of mass in plan:* Buildings twist during earthquake shaking due to mismatch in line of action of inertia force and resistance offered by structural members

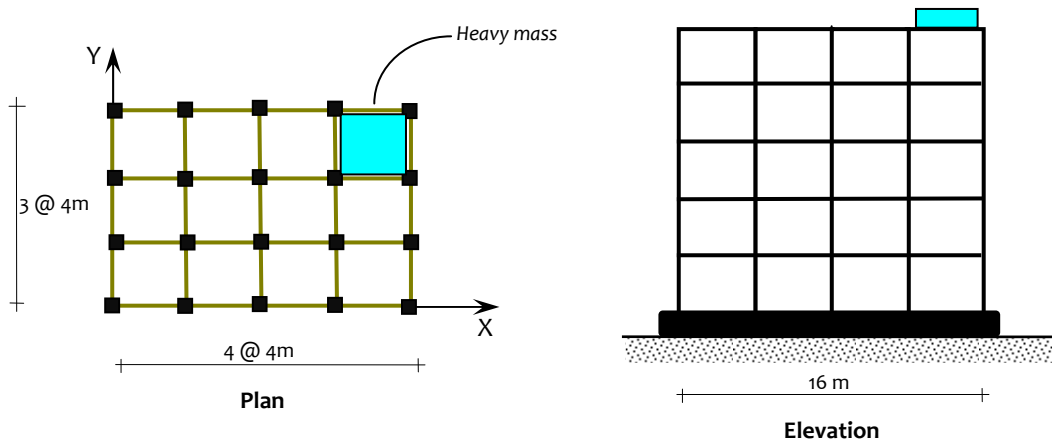


Figure 3.85: *Asymmetry of mass in plan:* Concentrated mass at one corner of building

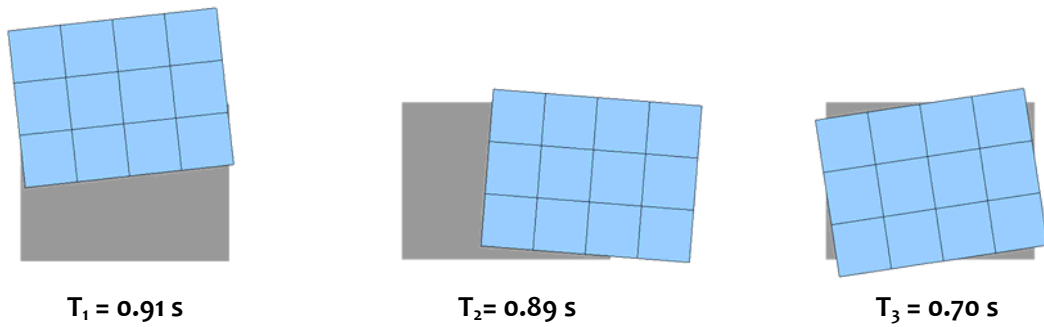


Figure 3.86: *Mass asymmetry in plan:* Twisting dominates the first three modes of oscillation

3.2.2 Mass Irregularity in Elevation

Multi-storeyed tall buildings often have service floors with heavy mass compared to regular floors (Figure 3.87). This causes sudden change or asymmetry in mass along the elevation of buildings. With increase in mass in one storey, there is increase in inertia force generated in that storey. If the percentage difference is small of change in mass in comparison to the total mass of the building, the effect of the mass irregularity is small on the mode shape in regular buildings. The difference becomes pronounced if the difference is large; the difference in response is explicit during nonlinear response of such buildings under strong earthquake shaking.

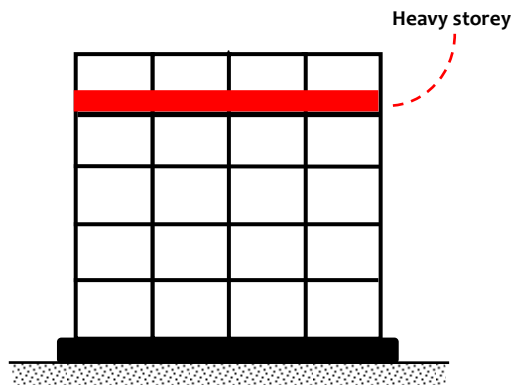
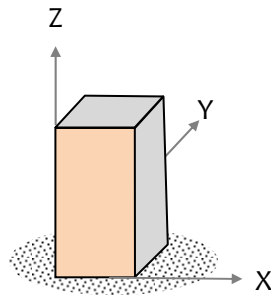


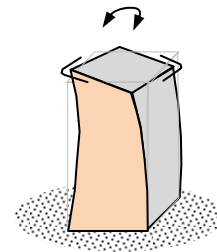
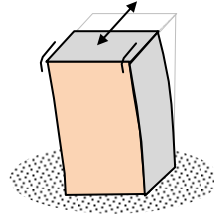
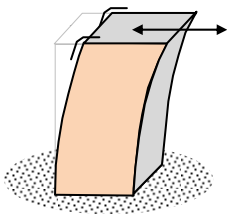
Figure 3.87: *Mass irregularity in elevation:* Sudden change in mass should be avoided

Animation Set 309

Two-dimensional modes shapes of buildings Effect of Asymmetry of Mass



First Three Modes of Oscillation



FIRST Mode

First translational mode in Y-direction with Torsion

SECOND Mode

First translational mode in X-direction with Torsion

THIRD Mode

First rotational mode about Z-axis

Click on the 3 items above to see the animation of the mode shapes

Best when viewed using Windows Media Player

3.4 INITIAL STIFFNESS

Initial lateral stiffness plays an important role in overall response of buildings. The amount of lateral load resisted by individual members in buildings is controlled by their lateral stiffness – stiffer elements attract more force than flexible ones. In addition, adequate overall stiffness is essential in a building to control overall lateral displacement during earthquake shaking. Thus, it is important to have uniform distribution of stiffness in a building to ensure uniform distribution of lateral deformation and lateral forces over the plan and elevation of a building.

3.4.1 Stiffness Irregularity in Plan

Irregularity in stiffness in plan occurs due to (a) use of columns of different sizes, (b) presence of structural wall on one side of buildings, or (c) presence of staircase or elevator core at one corner of buildings (Figure 3.88). Stiffness irregularity in plan causes twisting of buildings under lateral load (Figure 3.89). The significant modes of oscillation and the corresponding periods are shown in Figure 3.90 of the three buildings.

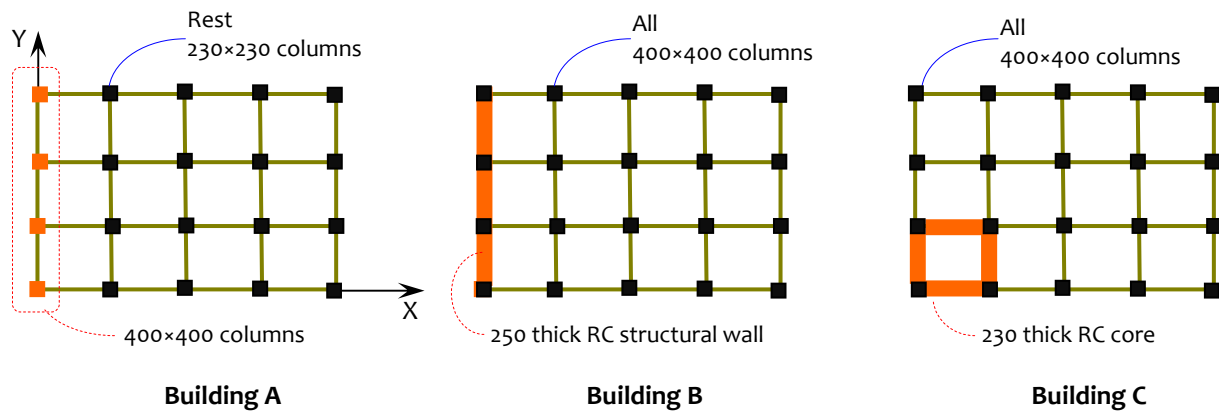


Figure 3.88: *Stiffness irregularity in plan:* Unequal stiffness of elements and their distribution in plan cause overall stiffness irregularity

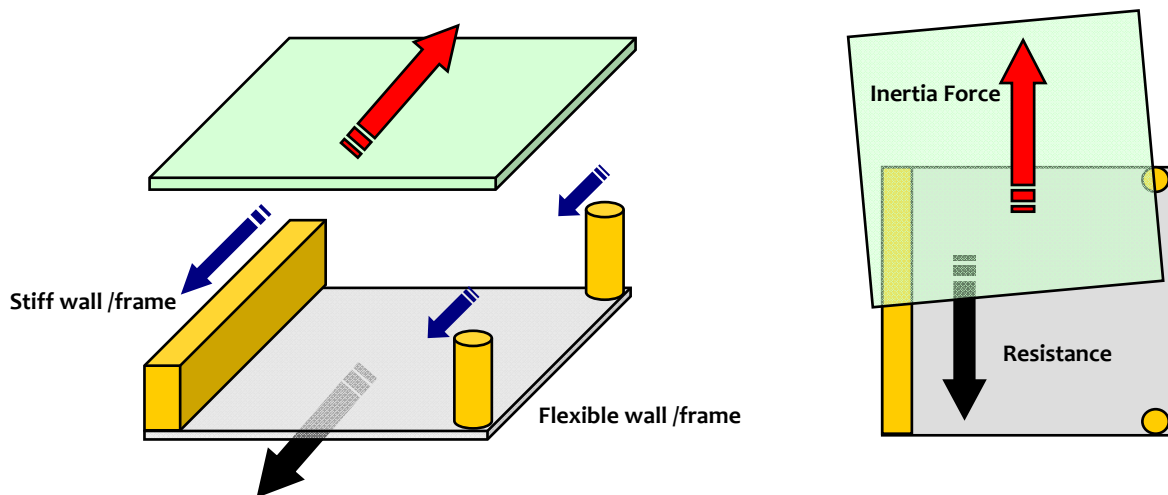
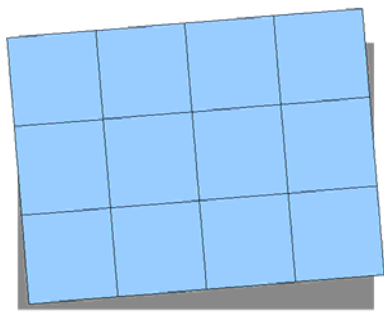
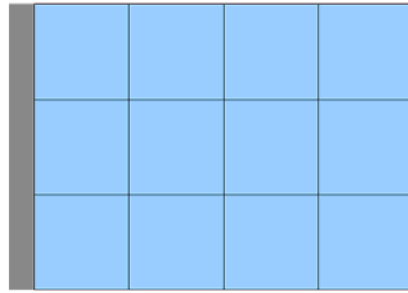


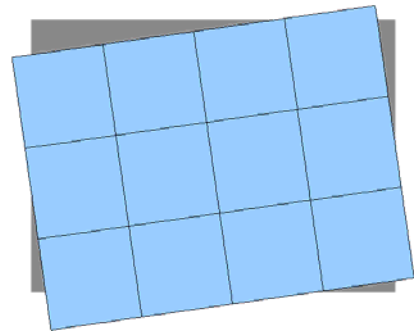
Figure 3.89: *Stiffness irregularity in plan:* Buildings twist during earthquake shaking due to mismatch in line of action of inertia force and resistance offered by structural members



$T_1 = 1.51s$

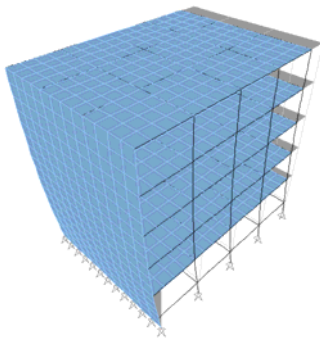


$T_2 = 1.44s$

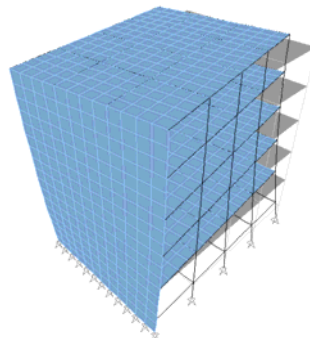


$T_3 = 0.98s$

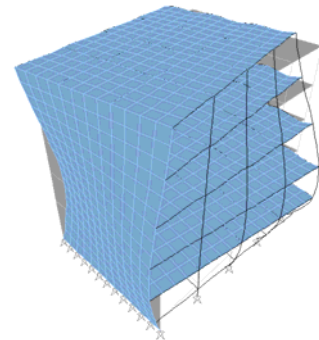
Building A



$T_1 = 0.89s$

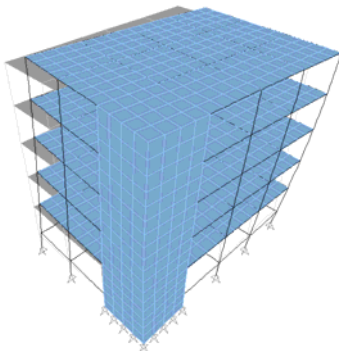


$T_2 = 0.85s$

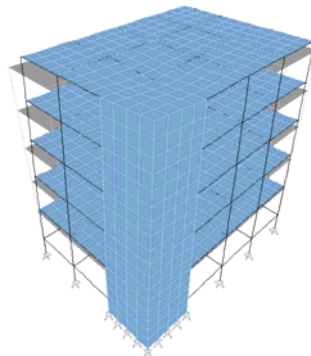


$T_4 = 0.26s$

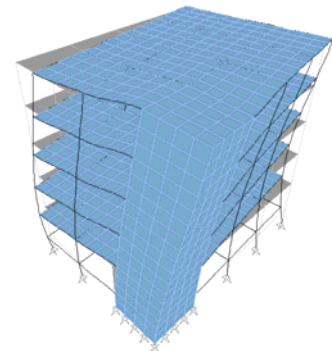
Building B



$T_1 = 0.50s$



$T_2 = 0.34s$



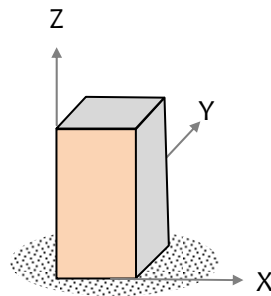
$T_4 = 0.22s$

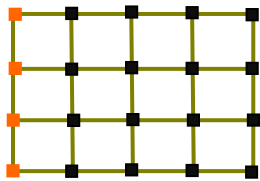
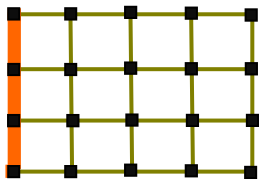
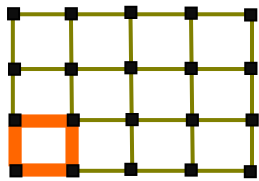
Building C

Figure 3.90: *Stiffness irregularity in plan:* Unequal stiffness of elements and their distribution in plan cause overall stiffness irregularity

Animation Set 310

Three-dimensional modes of buildings Effect of Stiffness Irregularity in Plan



Building A	Building B	Building C
 <p>FIRST Mode First translational mode in Y-direction with Torsion</p>	 <p>FIRST Mode First translational mode in X-direction</p>	 <p>FIRST Mode First translational mode in Y-direction with Torsion</p>
<p>SECOND Mode First translational mode in X-direction</p>	<p>SECOND Mode First torsional mode about Z-axis</p>	<p>SECOND Mode First diagonal translational mode in X-Y plane</p>
<p>THIRD Mode First torsional mode about Z-axis</p>	<p>THIRD Mode Second translational mode in X-direction</p>	<p>THIRD Mode First torsional mode about Z-axis</p>
<p>Click on the 9 items above to see the animation of the mode shapes Best when viewed using Windows Media Player</p>		

Staircase in buildings also causes the secondary effect of *short columns*, in addition to causing twist of the building due to stiffness irregularity in plan. *Short column effect* is caused by the intermediate landings (e.g., mid-landing in dog-legged stairs) which divide the adjoining columns into shorter segments. This result in enhanced shear demand in these short columns with additional stiffness introduced at intermediate levels (Figure 3.91). Axial load increases in these columns due to increased rigidity of the particular bay. This increase in axial force and shear force together can cause brittle failure of these short columns.

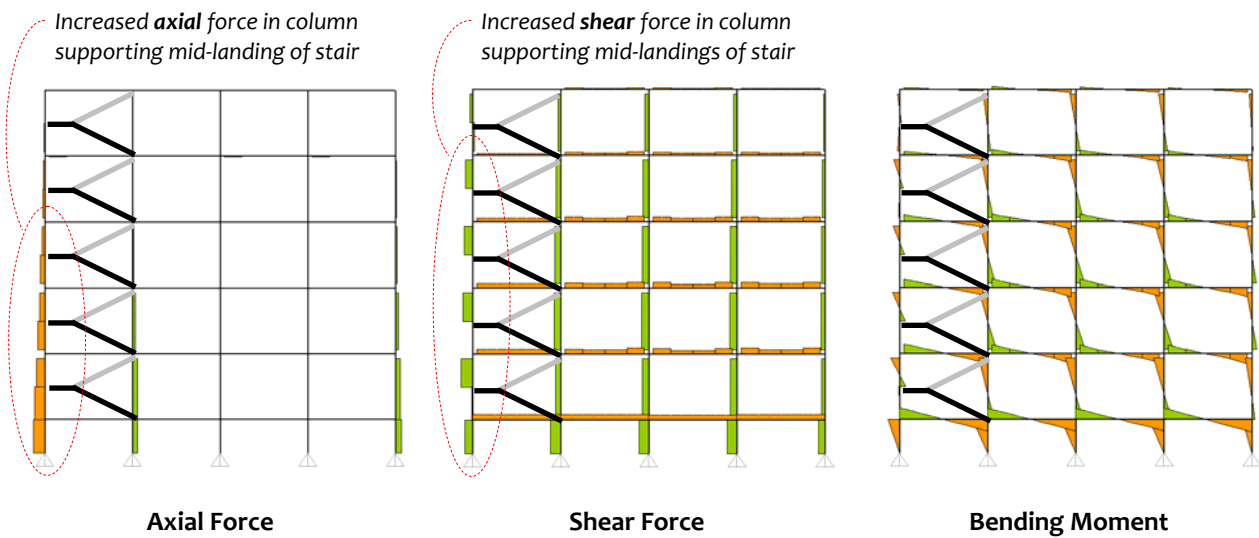
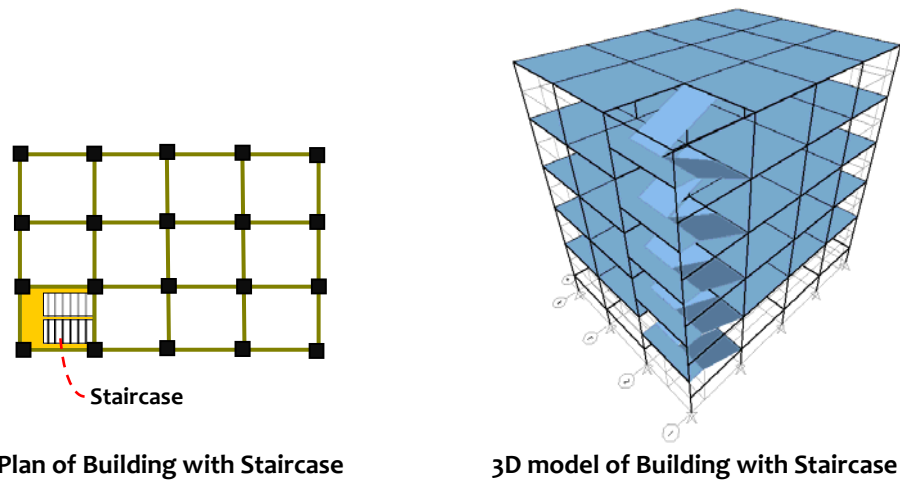
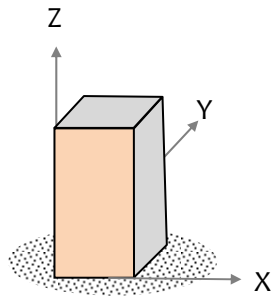


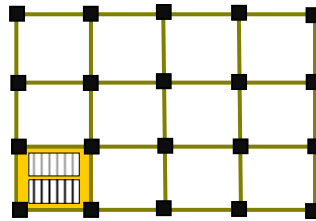
Figure 3.91: Building with staircase: Stair slabs provide intermediate restraints leading to short-column effect

Animation Set 311

Three-dimensional modes of buildings **Effect of Stiffness Irregularity in Plan**



Building with Staircase



FIRST Mode

First translational mode in Y-direction with Torsion

SECOND Mode

First translational mode in X-direction

THIRD Mode

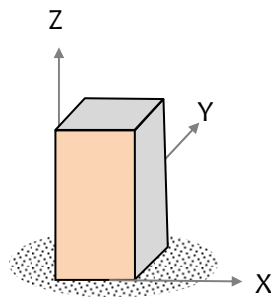
First torsional mode about Z-axis

Click on the 3 items above to see the animation of the mode shapes

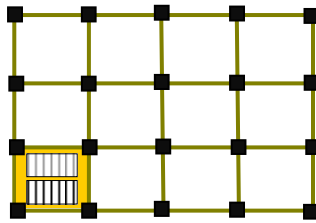
Best when viewed using Windows Media Player

Animation Set 312

Load Transfer Mechanism Presence of Staircase



Building with Staircase



Axial Force Diagram

Shear Force Diagram

Bending Moment Diagram

Click on the 3 items above to see the animation of the Force Distribution
Best when viewed using Windows Media Player

3.4.2 Stiffness Irregularity in Elevation

Irregularity in stiffness along the height of buildings arises from both architectural and structural choices. Often, the former is a more formidable choice to ensure safety, since it is driven by considerations other than safety. On the other hand, the latter is more a subtle choice made by structural designers, sometime inadvertently. In both cases, the consequence is severe. This section explains some of these choices.

(a) Open or Flexible Storey in Buildings

Lateral stiffness irregularity occurs in elevation when (a) sizes of lateral load resisting elements are varied along the height of buildings, and (b) additional elements are added or existing elements are removed (Figure 3.92). In building C (in Figure 3.92), the column sizes are reduced to 230mm×230mm from 400mm×400mm, while buildings A and B have additional masonry infill except at one storey. Buildings A and B represent moment frames with masonry (brick) infill walls. Masonry has good strength in compression. Thus, under lateral loads, the load transfer takes place through compressive strut action in the infilled masonry portion – this action is somewhat similar to that seen when diagonal compression braces are present in frames (Figure 3.93). Hence, modeling of unreinforced masonry infilled frame buildings for structural analysis should include masonry infills as diagonal *compression-only* strut members. Stiffness irregularity in elevation causes unwarranted change in demands on the structural elements (Figure 3.94). Also, reduction of lateral stiffness causes increase in displacement demand in storeys with less stiffness, called *soft storey* (Figure 3.95).

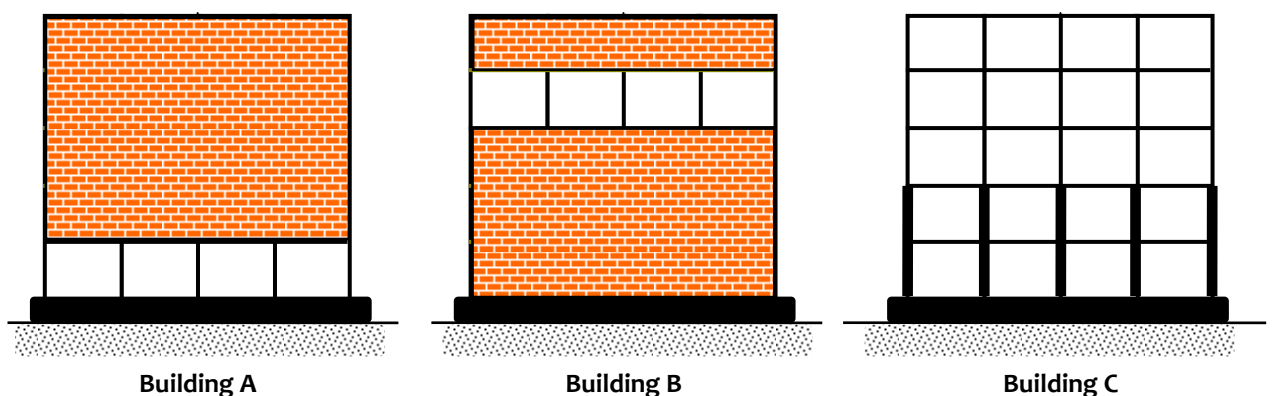


Figure 3.92: *Stiffness irregularity in elevation:* Variation of element size and presence of additional or absence of elements in elevation cause overall stiffness irregularity

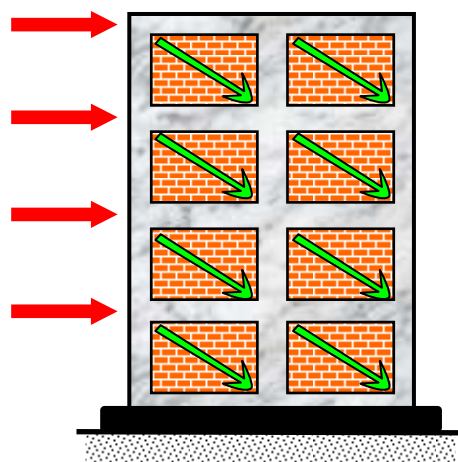


Figure 3.93: *Masonry infilled frame:* Infill helps transfer lateral loads through diagonal strut action and reduces demand on columns

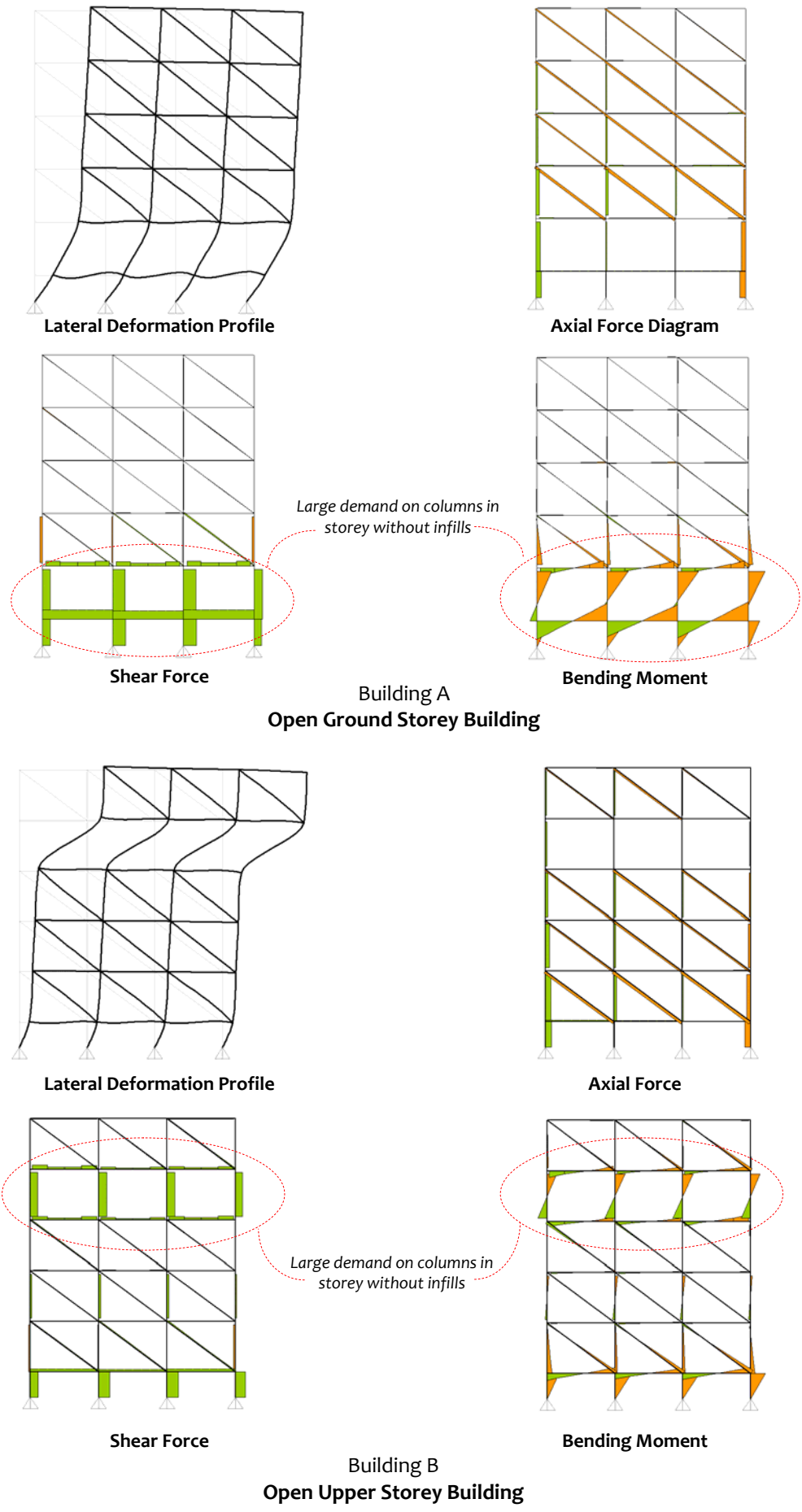


Figure 3.94: *Masonry infilled frame:* Discontinuity of infill in one storey cause significant demand on the columns in the storey

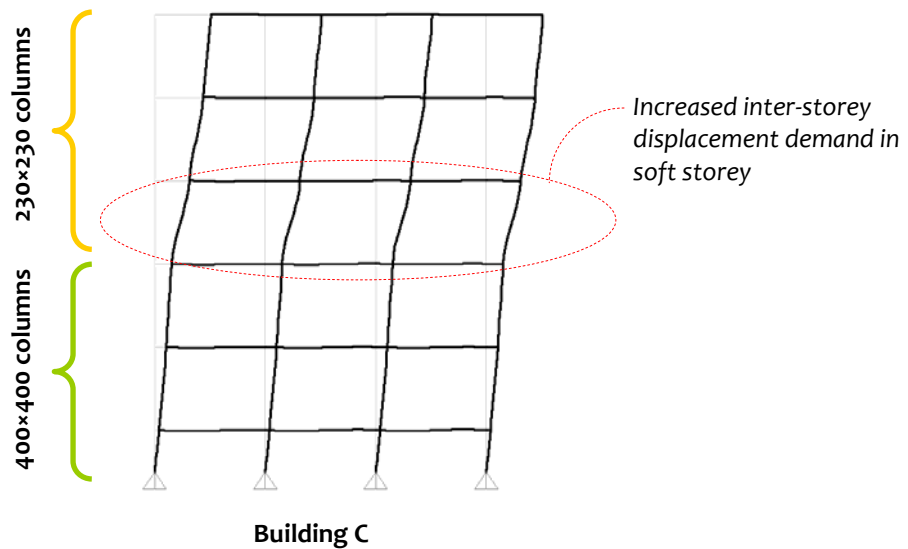


Figure 3.95: *Stiffness irregularity in elevation:* Stiffness irregularity in elevation increase deformation demand in storeys with less stiffness

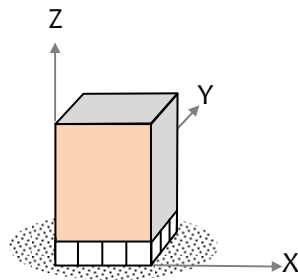
Stiffness irregularity owing to the presence of unreinforced masonry infills can be captured at the design stage itself by modeling the infills using compression-only struts, with properties of the strut guided by literature (*e.g.*, IITK-GSDMA, 2005). When the stiffness irregularity is noticed in the structural analysis of the building subjected to equivalent static lateral loads, designers may choose one of following options, namely

- (a) Designing all members of the frame according to the irregular forces,
- (b) Strengthening the columns and beams in the vicinity of the irregularity for higher forces than those received from structural analysis, and
- (c) Reducing the stiffness irregularity by adding a *new* stiff lateral load resisting system in the building, whose lateral stiffness is much larger than that of the original system of the building that has irregularity, *e.g.*, RC structural wall in a RC moment frame building with unreinforced masonry infills.

But, the first two choices are not rational. The poor performance of the structure due to stiffness irregularity cannot be avoided either by designing the members in that storey or even with strengthening the columns and beams at the location of irregularity. Hence, the only option available is to ensure that the stiffness irregularity is mitigated by improving the stiffness of the whole building with a new system.

Animation Set 313

Three-dimensional modes of buildings
Effect of Stiffness Irregularity in Elevation



<p>First Mode <u>Translational mode in Y-direction</u></p>	<p>First Mode <u>Translational mode in Y-direction</u></p>
<p>Second Mode <u>Translational mode in X-direction</u></p>	<p>Second Mode <u>Translational mode in X-direction</u></p>
<p>Third Mode <u>Torsional mode about Z-axis</u></p>	<p>Third Mode <u>Torsional mode about Z-axis</u></p>
<p><i>Click on the 6 items above to see the animation of the mode shapes</i> Best when viewed using Windows Media Player</p>	

(b) Plinth and Lintel Beams in Buildings

Bands (e.g., Plinth and Lintel) are primarily associated with load bearing masonry structure. These bands are provided often in reinforced concrete buildings without considering their effect on the behaviour of the buildings. Failure observed during the past earthquake has illustrated the importance of considering these bands during the analysis and design stage. The effect is presented separately of each of these on the behaviour of buildings.

Plinth beams are structural members (beams) and reduce the effective length of ground storey column which are generally longer than those in the upper storeys. As a result, the stiffness of the ground storey columns is altered by the addition of plinth beams. Deformation and shear force demand imposed on the benchmark building with and without plinth beam is shown in Figure 3.96. The deformation demand on the building without plinth beam is largely concentrated at the ground storey level because of low lateral stiffness of the longer columns; this is reduced significantly by the addition of plinth beam. But, shear force increases with addition of plinth beam, particularly in the ground storey columns due to the short column effect. A more practical solution is to use larger size ground storey column such that the stiffness of the ground storey is close to the stiffness of the upper storey. In such case, both lateral deformation and shear force demands are well distributed along the building height.

Lintel beams introduce local deformation restraint at locations, when they frame into columns. The level of restraint depends on the relative stiffness of the lintel beam and the column. With increase in lintel size, deformation restraint offered increases, and the column region between the lintel and roof beam exhibits short column effect. Comparison of shear demand imposed, due to same lateral load, on the columns of the benchmark building without and with lintel of various sizes (100, 200 and 300mm) are as shown in Figure 3.97. The shear demand imposed on columns increases with increase in size of lintel. Amplification of shear demand on columns due to presence of large lintels may lead to brittle shear failure of columns.

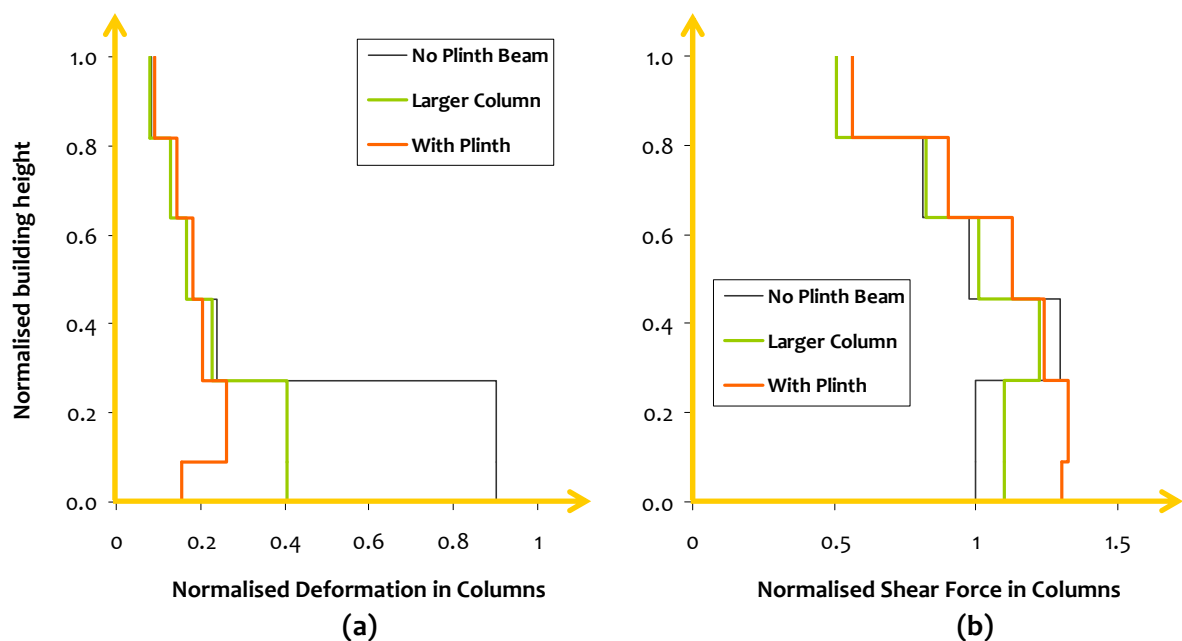


Figure 3.96: *Building with Plinth Beam:* Plinth beams reduces lateral deformation but increases shear force demand on ground storey columns

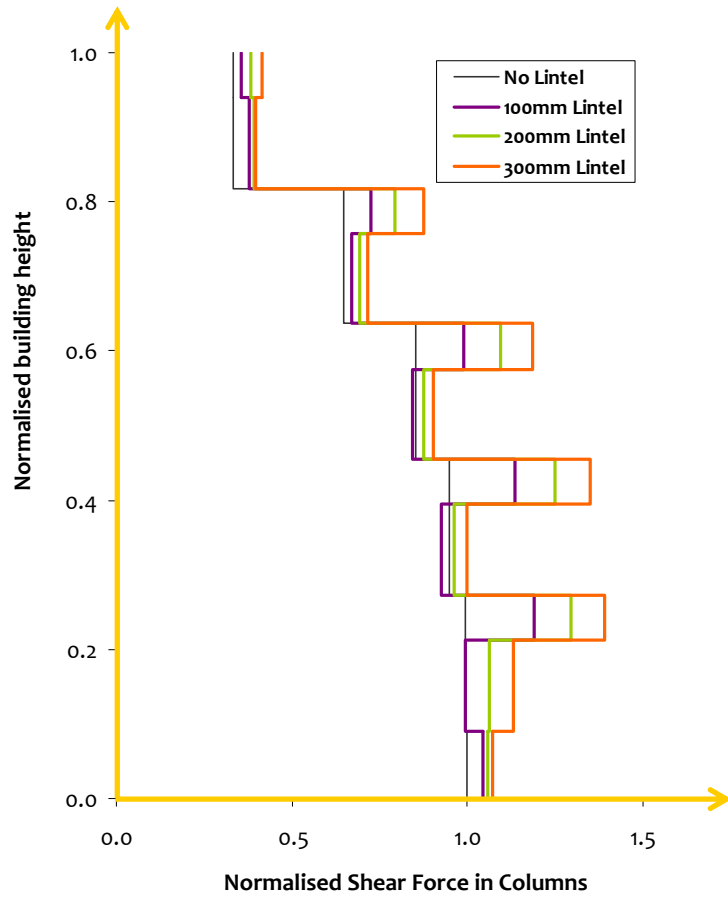
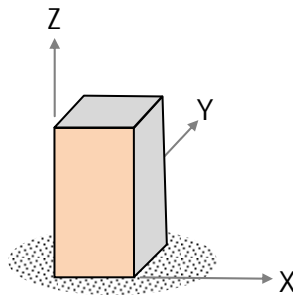
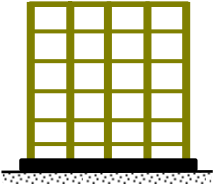
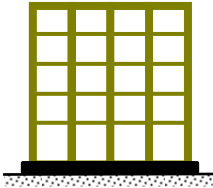


Figure 3.97: *Building with Lintel Beam: Deeper lintel beams induce more short column effect*

Animation Set 314

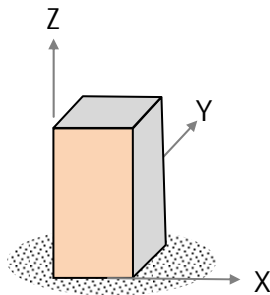
Lateral Deformation of Building Effect of Plinth Beam

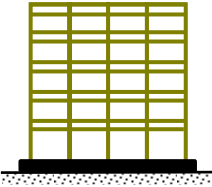
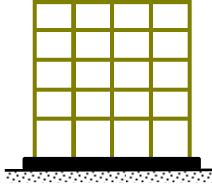


<i>Building with Plinth Beam</i>	<i>Building without Plinth Beam</i>
	
<u>Uniform Inter-storey Drift</u>	<u>Inter-storey Drift Concentrated at Ground Floor level</u>
<p><i>Click on the 2 items above to see the animation of the load transfer mechanism</i> Best when viewed using Windows Media Player</p>	

Animation Set 315

Force Flow Effect of Lintel Beam



Building with Lintel Beam	Building without Lintel Beam
 <p><u>Shear Force</u></p>	 <p><u>Shear Force</u></p>
<p>Click on the 2 items above to see the animation of the load transfer mechanism Best when viewed using Windows Media Player</p>	

(c) Buildings on Slope

Buildings are constructed on slopes in hill regions. Typical features of these buildings include *columns of unequal lengths along the slope*, and *lack of proper foundation well embedded into the soil underneath* to provide adequate translational fixity under lateral earthquake shaking. Two basic types of fixity conditions are achieved depending on construction type and local soil/rock strata; one that provides full translational and rotational restraints, and the other that do not provide the same. Lack of translational and rotational fixity occurs due to slope subsidence particularly during strong earthquake shaking. Actual degree of fixity (translational and rotational) varies.

Consider two buildings with three storeys above and four storeys below ground level, but with different restraints at base of columns (Figure 3.98); Building A has fixed column bases, and Building B has roller column base (to capture effects of sliding along the slope during strong earthquake shaking) except underneath the tallest valley-side column. Buildings rested on hard rock strata behave more like *Building A* during low intensity of ground shaking, wherein the lateral frictional resistance under the columns is more than the horizontal shear induced in the building by the lateral shaking. Once the inertia force exceeds the frictional resistance during strong ground shaking, these buildings behave more like *Building B*, wherein except the last column on the valley side, all other column bases start sliding from the ground in the lateral direction.

Comparison is shown in Figure 3.99 of deformed shapes of the two buildings, and axial forces, shear forces and bending moments in members of these two possible building conditions under lateral force. Under small intensity of shaking, the lateral deformation is concentrated only in the portion of the building *ABOVE the uppermost support* (as in Building A), and cause predominantly axial force in the valley-side columns below the ground level. This additional axial force, along with the existing gravity load, may cause compression failure of these columns, as observed in some recent earthquakes, like the 2011 Sikkim Earthquake. Under strong shaking, most column bases loose contact with the soil and cause large axial force, shear force and bending moment in columns, particularly in those *BELOW the uppermost support* (as in Building B), and is likely to cause catastrophic collapse of buildings under combined action of axial force, shear force and bending moment. Further, stability of such buildings is jeopardized by slope instability that can be triggered by ground shaking of strong intensity.

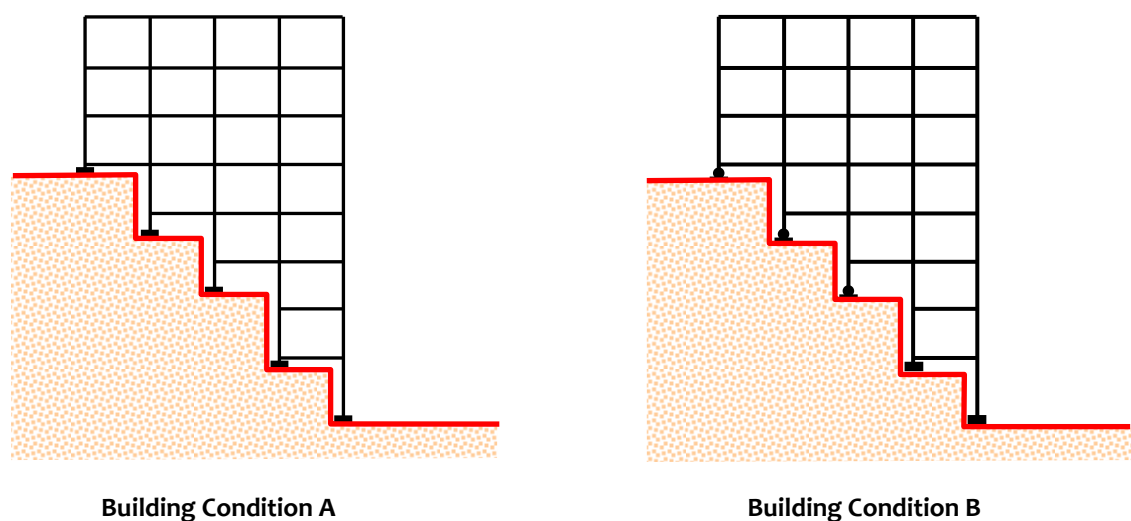


Figure 3.98: *Buildings on slope:* Stiffness irregularity in elevation due to unequal length of columns and degree of fixity at column base

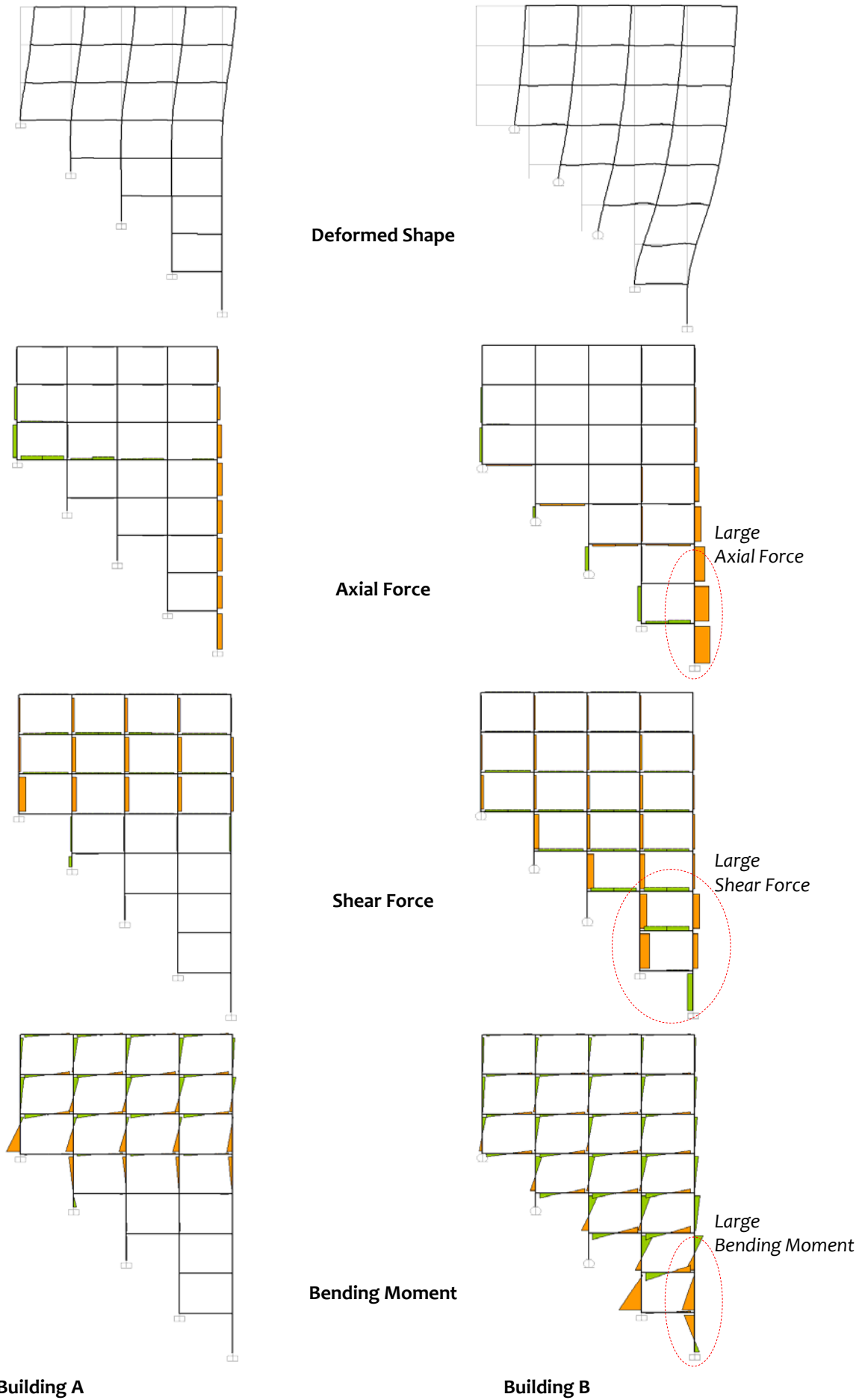
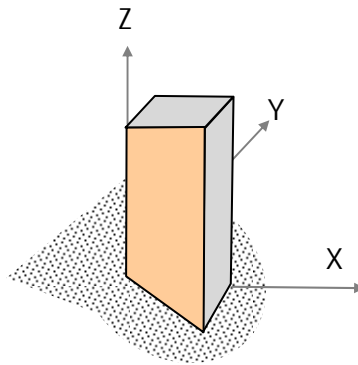
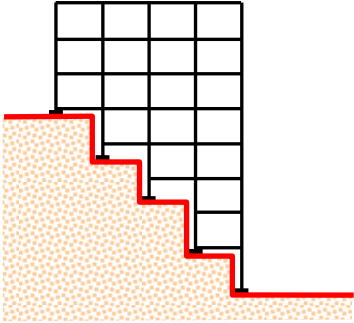
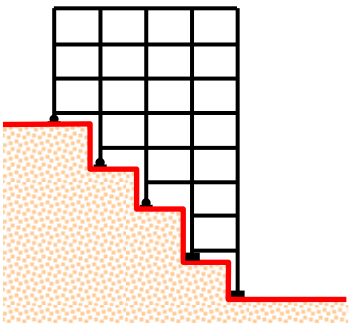


Figure 3.99: Buildings on slope: Deformation and force distribution

Animation Set 316

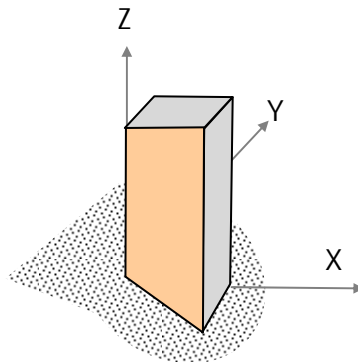
Three-dimensional modes shapes of buildings Building on Slopes

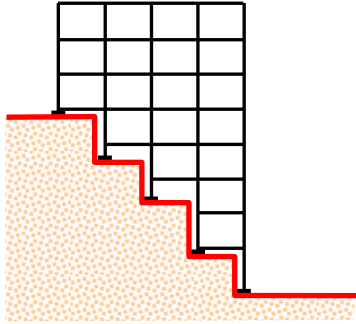
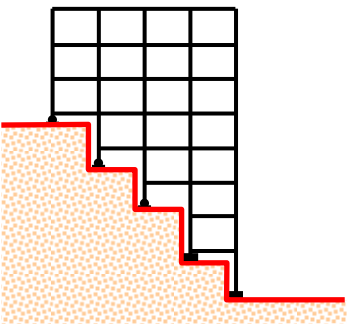


<p>Building on Slope with Fixed Base</p> 	<p>Building on Slope with Roller Base</p> 
<p>First Mode <u>Translational in X-direction with Torsion</u></p>	<p>First Mode <u>Translational in X-direction with Torsion</u></p>
<p>Second Mode <u>Translational in Y-direction</u></p>	<p>Second Mode <u>Translational in Y-direction</u></p>
<p>Third Mode <u>Torsional Mode about Z axis</u></p>	<p>Third Mode <u>Torsional Mode about Z axis</u></p>
<p>Click on the 3 items above to see the animation of the load transfer mechanism Best when viewed using Windows Media Player</p>	

Animation Set 317

Force Flow and Deformation
Building on Slopes



<p><i>Building on Slope with Fixed Base</i></p> 	<p><i>Building on Slope with Roller Base</i></p> 
<p><u>Axial Force</u></p>	<p><u>Axial Force</u></p>
<p><u>Shear Force</u></p>	<p><u>Shear Force</u></p>
<p><u>Bending Moment</u></p>	<p><u>Bending Moment</u></p>
<p><u>Lateral Deformation</u></p>	<p><u>Lateral Deformation</u></p>
<p><i>Click on the 8 items above to see the animation of the load transfer mechanism</i> Best when viewed using Windows Media Player</p>	

(d) Set-back and Step-back Buildings

Irregularity in overall geometry of the building in elevation also is detrimental to good earthquake behaviour of buildings. The common types of overall geometric irregularities include *set-back buildings* and *step-back buildings* (Figure 3.100). These geometric forms arise largely from architectural extravaganzas, and result in concave geometries that have a number of re-entrant corners at which load paths are disturbed requiring sharp bends.

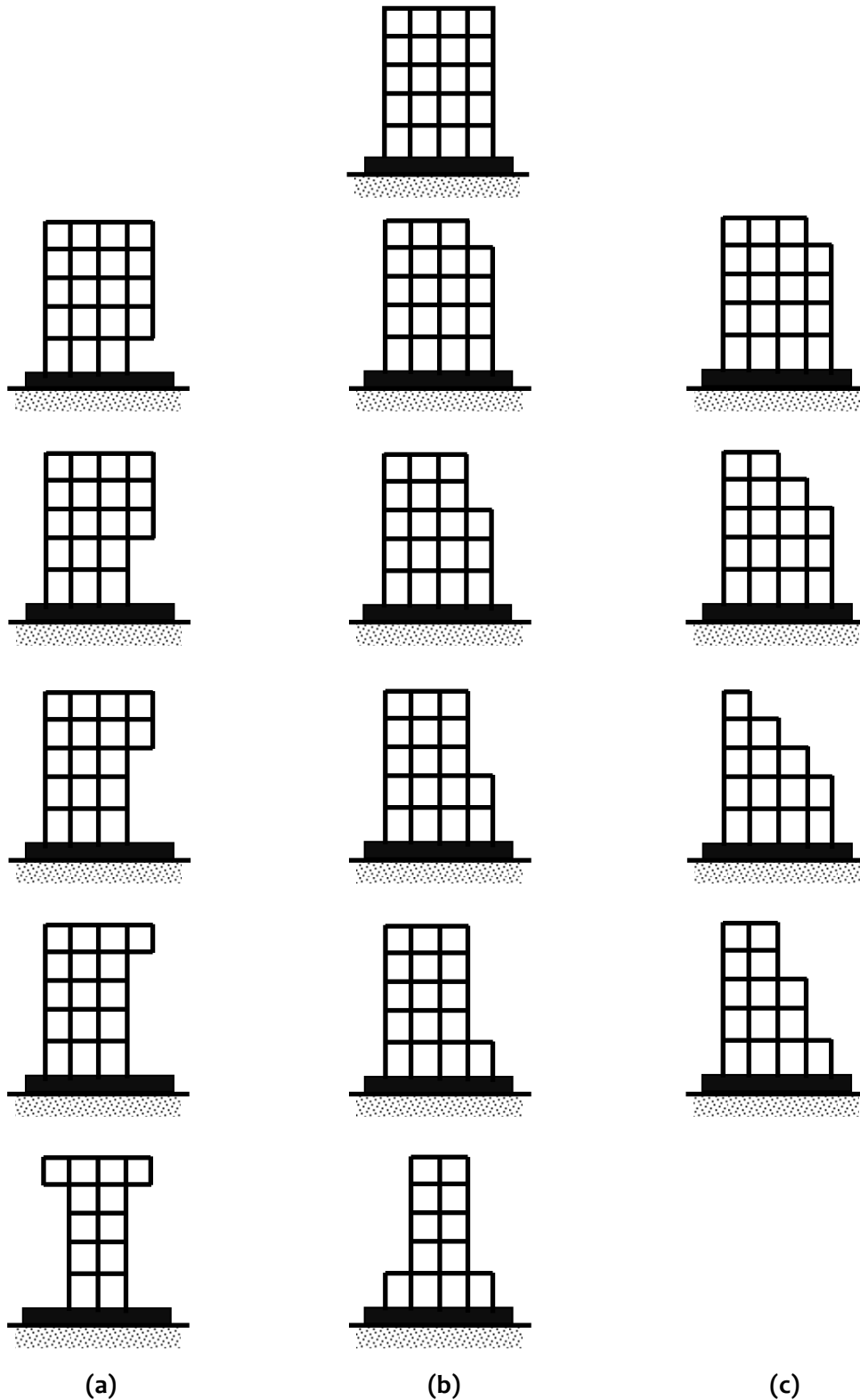


Figure 3.100: Buildings with vertical irregularity in overall geometry: (a) Set-back buildings, and (b) & (c) Step-back buildings

Stepped buildings have frames of different height (Figure 3.101). Thus, both mass and stiffness distribution changes along the height; the center of mass and center of stiffness of different storeys do not lie along the same vertical line, as is the case in buildings with regular overall geometry. This results in twisting of buildings. The natural periods of these buildings are shown in Table 3.15 along with associated fundamental mode shapes in Figures 3.102 and 3.103.

Comparison of deformed shape, axial force, shear force and bending moment of periphery frames (Frame AA and Frame BB in Figure 3.101) when subjected to lateral force indicates (Figure 3.104):

- (a) Deformation of taller (flexible) frame is larger than that of shorter (stiff) frame; and
- (b) Force demand imposed on taller frame is higher than that on shorter stiffer frame, because the mass imposed on former is higher than that on the latter.

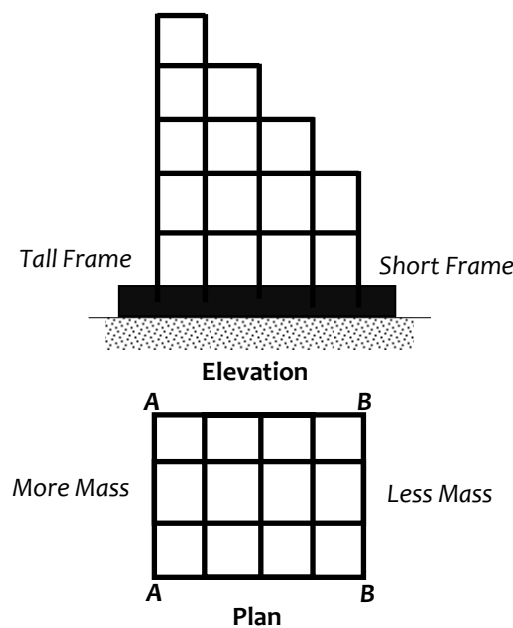















Figure 3.101: Characteristics of buildings with vertical irregularity in overall geometry: Step-back buildings have frames of different heights, leading to unsymmetrical stiffness and mass distributions in plan

Table 3.15: Buildings with vertical irregularity in overall geometry: Natural periods and associated mode shapes

<i>Type of Building</i>	<i>Mode 1</i>	<i>Mode 2</i>	<i>Mode 3</i>
	Y-translation (0.89 s)	X translation (0.87 s)	Torsion (0.79 s)
	Y-translation with torsion (0.87 s)	X translation (0.84 s)	Torsion (0.74 s)
	Y-translation with torsion (0.84 s)	X translation (0.78 s)	Torsion (0.65 s)
	Y-translation with torsion (0.78 s)	X translation (0.70 s)	Torsion (0.54 s)
	Y-translation with torsion (0.86 s)	X translation (0.81 s)	Torsion (0.67 s)
	Y-translation with torsion (0.82 s)	X translation (0.75 s)	Torsion (0.58 s)
	Y-translation with torsion (0.86 s)	X translation (0.83 s)	Torsion (0.69 s)
	Y-translation (0.73 s)	X translation (0.72 s)	Torsion (0.56 s)
	Y-translation with torsion (0.99 s)	X translation (0.96 s)	Torsion (0.82 s)
	Y-translation with torsion (1.03 s)	X translation (0.96 s)	Torsion (0.82 s)
	Y-translation with torsion (1.03s)	X translation (0.94 s)	Torsion (0.82 s)
	Y-translation with torsion (0.99 s)	X translation (0.92 s)	Torsion (0.82 s)
	Torsion (1.06 s)	Y translation (1.05 s)	X-translation (1.00 s)

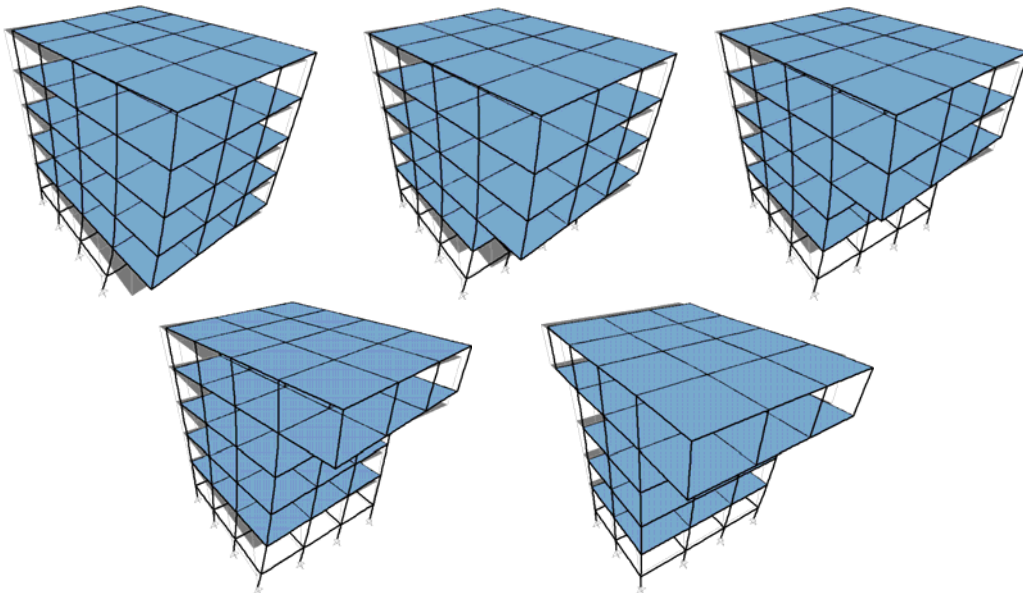


Figure 3.102: *Fundamental modes shapes of buildings with vertical irregularity in overall geometry:
Twisting in Set-back buildings*

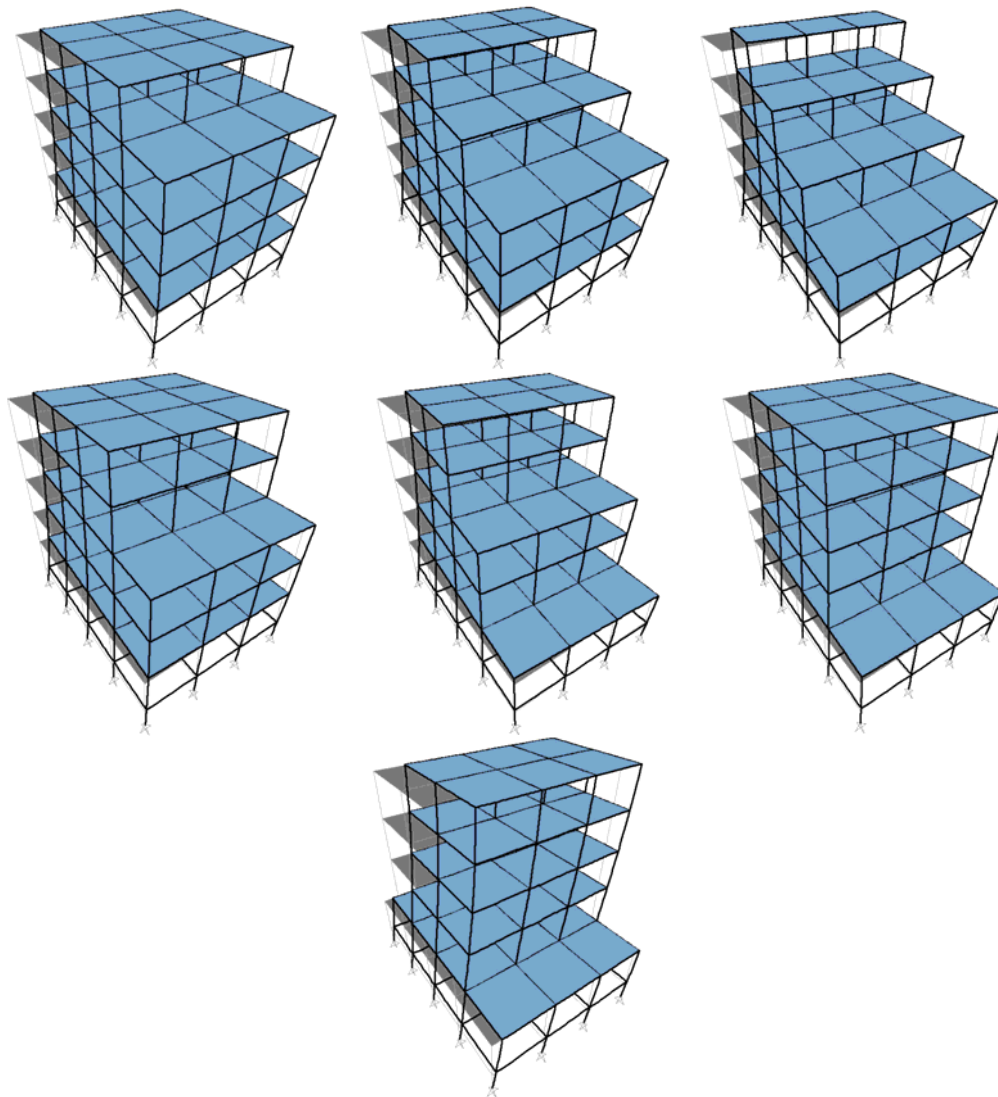


Figure 3.103: *Fundamental modes shapes of buildings with vertical irregularity in overall geometry:
Twisting in Step-back buildings*

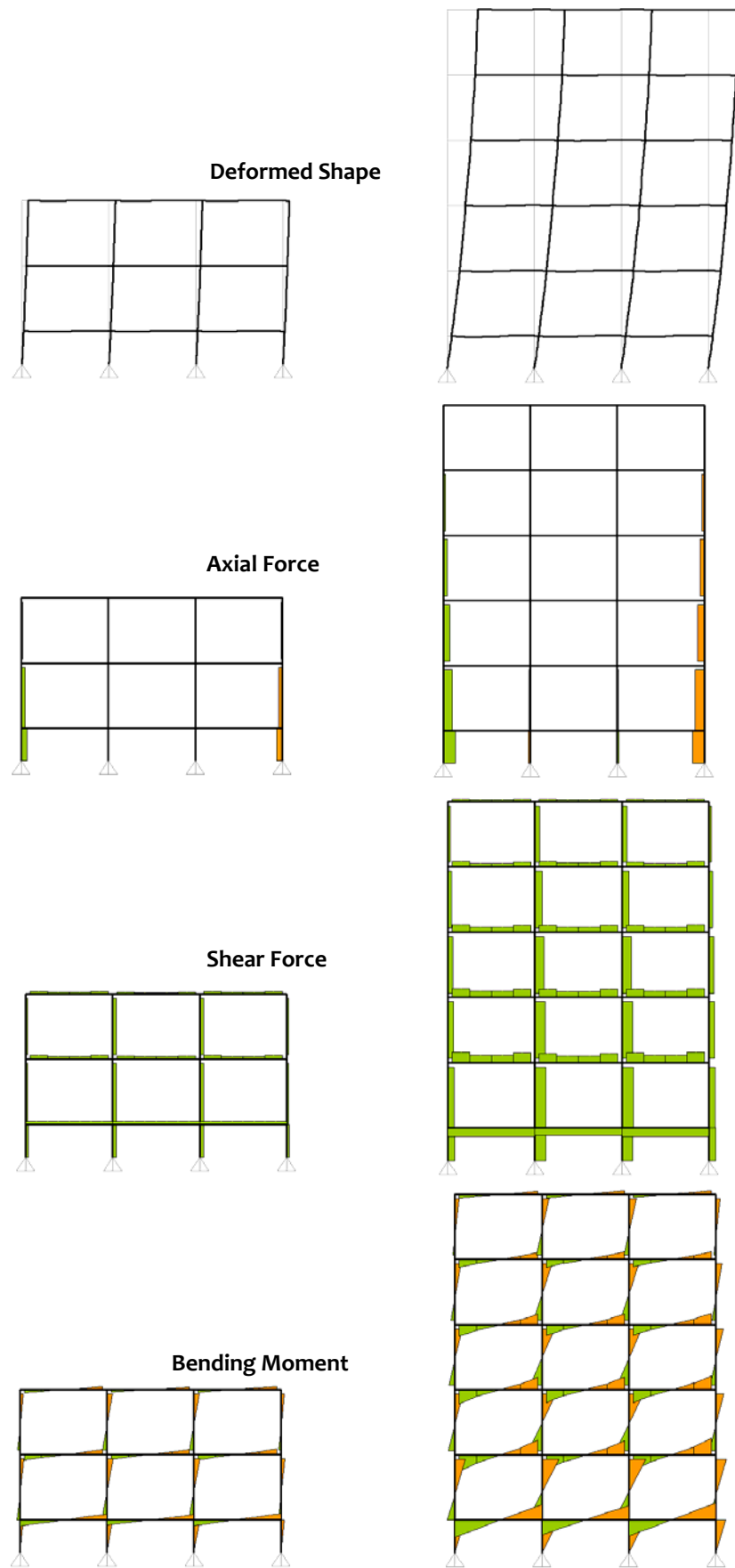
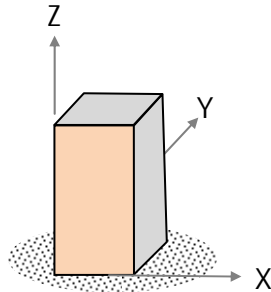
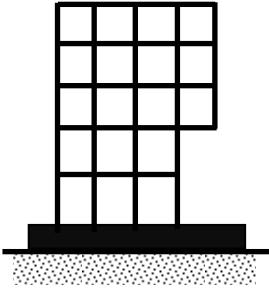
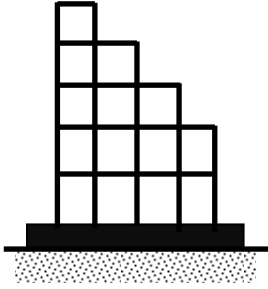


Figure 3.104: Buildings with *Step-back*: Deformation and force distribution

Animation Set 318

Three-dimensional modes shapes of buildings
Effect of Set-back and Step-back in Frame Buildings



<p><i>Building with Set-back</i></p> 	<p><i>Building with Step-back</i></p> 
<p>First Mode <u>Translational in Y-direction with Torsion</u></p>	<p>First Mode <u>Translational in Y-direction with Torsion</u></p>
<p>Second Mode <u>Translational in X-direction</u></p>	<p>Second Mode <u>Translational in X-direction</u></p>
<p>Third Mode <u>Torsional Mode about Z axis</u></p>	<p>Third Mode <u>Torsional Mode about Z axis</u></p>
<p><i>Click on the 6 items above to see the animation of Three-dimensional modes shapes</i> Best when viewed using Windows Media Player</p>	

3.4.3 Adjacency

Lateral stiffness controls lateral displacement in buildings. Often, two parts of the same building or two different buildings are built close to each other, without recognizing the implications of such adjacency during earthquake shaking. In the first case in particular, the two parts of the same building are separated only by small *Separation Joints* (Figure 3.105). Understandably, the gap to be provided between them should be such that the two units do not pound on each other. Usually, 30-40mm is gap provided, without actually calculating the separation required from seismic considerations.

In four cases, two adjacent buildings or parts of a building should be separated with this designed gap. These cases are when:

- (1) Buildings have alphabetic plan shapes; they could be separated at the junctions of the different wings that meet each other from different directions,
- (2) Two parts of a building are of different heights; the two parts tend to swing differentially,
- (3) Buildings rest on two different soil masses that differ in their flexibility; the different soil strata make the two parts oscillate differentially under the same shaking, and
- (4) Buildings have two different masses within it; they need to be separated at the junction.

But, it is possible that the adjacent buildings or parts may collide with each other during earthquake shaking. Hence, at least a minimum design separation distance needs to be provided to avoid pounding of two adjacent buildings or parts of a building during earthquake shaking. Thus, when a designer is compelled to build close to an adjacent building or make a building in two parts, there is a need to recognize the actual lateral displacement of each building or part of the building, and provide calculated amount of gap that they need between them. When this is done, the junction of the two buildings or two parts of the same building is called a *Seismic Joints*, as against the *Expansion Joints* that are made from thermal considerations.

The use of separation joints is common practice in India - building is constructed with a joint in between, even though the foundation may be the same (Figure 3.106a). This practice is motivated by thermal considerations of expansion and contraction of parts of the building; hence, this is also called *Expansion Joint*. It uses only nominal separation (of about 30 mm) between two adjoining constituent units of a building - only to allow thermal expansion of the two parts of the building. Also, there is a practice of row construction, especially in older developments, where different buildings are built touching each other (Figure 3.106b). Further, there is a third category of such construction, where a designer is required to make buildings with alphabetic shapes in plan from functional and other considerations; it is decided to split the different wings of the building into independent rectangular parts (Figure 3.106c). But, during earthquake shaking, these adjoining buildings or parts of the same building shake independently and even pound on each other.

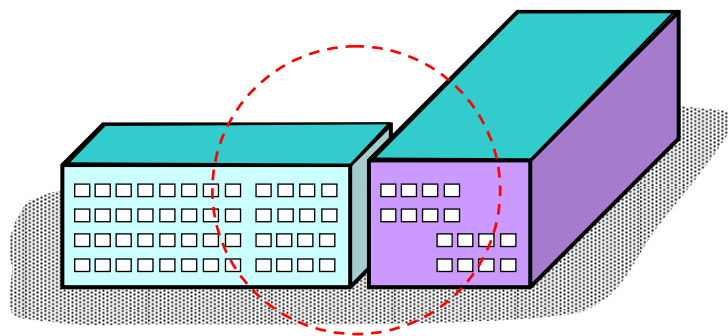


Figure 3.105: *Separation joints:* Separation between two parts of the same building or two adjoining buildings

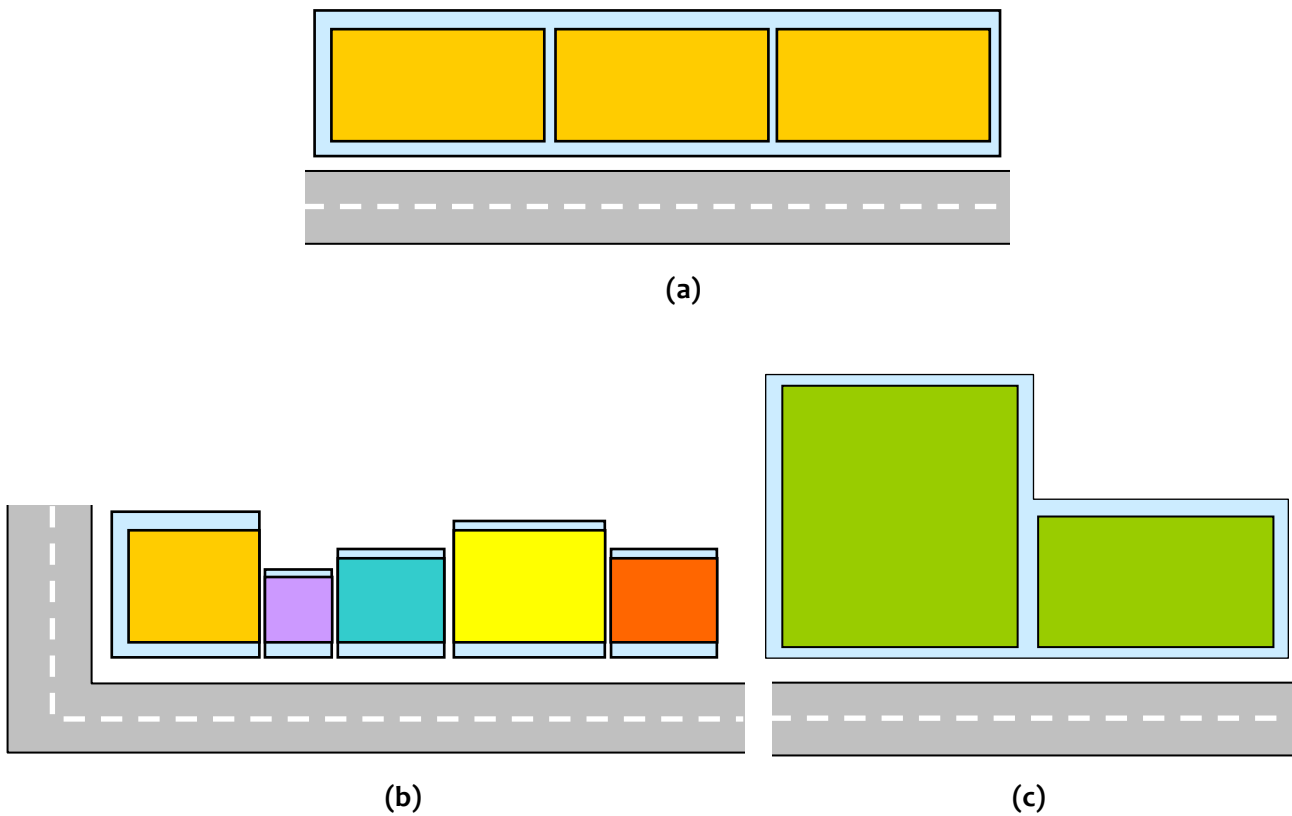


Figure 3.106: Building plan configurations that lead to two buildings / parts of building that pound on each other: (a) long building split in parts, (b) row construction, and (c) L-shaped building made in two parts

There are four possible configurations of such buildings or part of the same building along the height (Figure 3.107), namely (a) two parts with same overall height and same floor heights, (b) two parts with same overall height and different floor heights, (c) two parts with different overall height and same floor heights, and (d) two parts with different overall height and different floor heights. Of the four possible configurations, the case with different floor heights is most serious (Figures 3.107b and d); the floor of one building comes and pounds on the column of the adjoining part of the building at a location in between its ends (Figure 3.107e). This case should be avoided at any cost. In buildings with the configurations shown in Figures 3.107a and c, if adequate separation cannot be provided, the only option is to stitch the buildings together (Figure 3.108) at all floor levels. Here, care is required to ensure that the integrated building has mode shapes and deformation shapes that do not have any detrimental effects on the safety of the building.

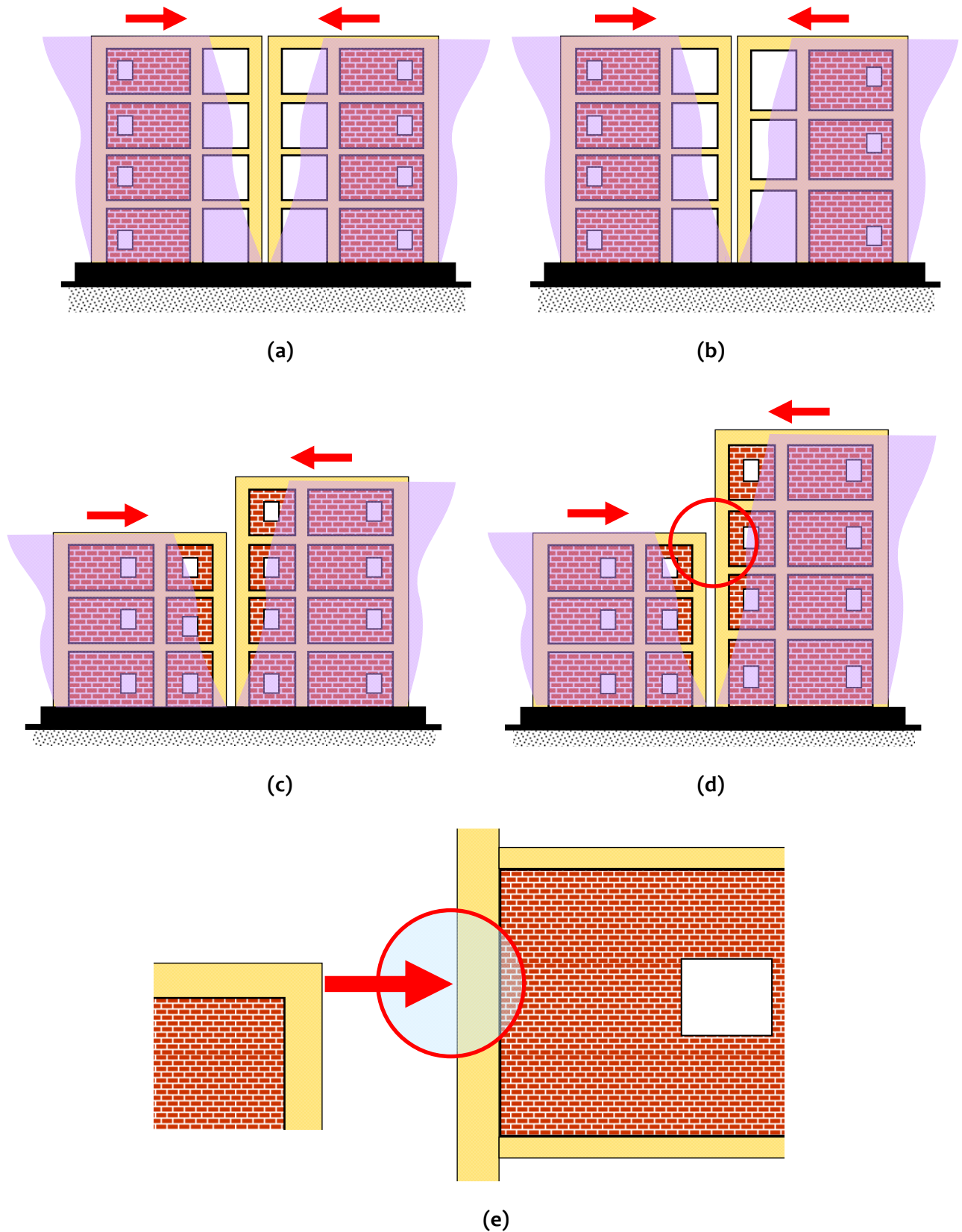


Figure 3.107: *Pounding within a building with expansion joints:* Four possible configurations of buildings - (a) two parts with same overall height and same floor heights, (b) two parts with same overall height and different floor heights, (c) two parts with different overall height and same floor heights, (d) two parts with different overall height and different floor heights, and (e) local action of a floor on the column of the adjoining (part of the) building

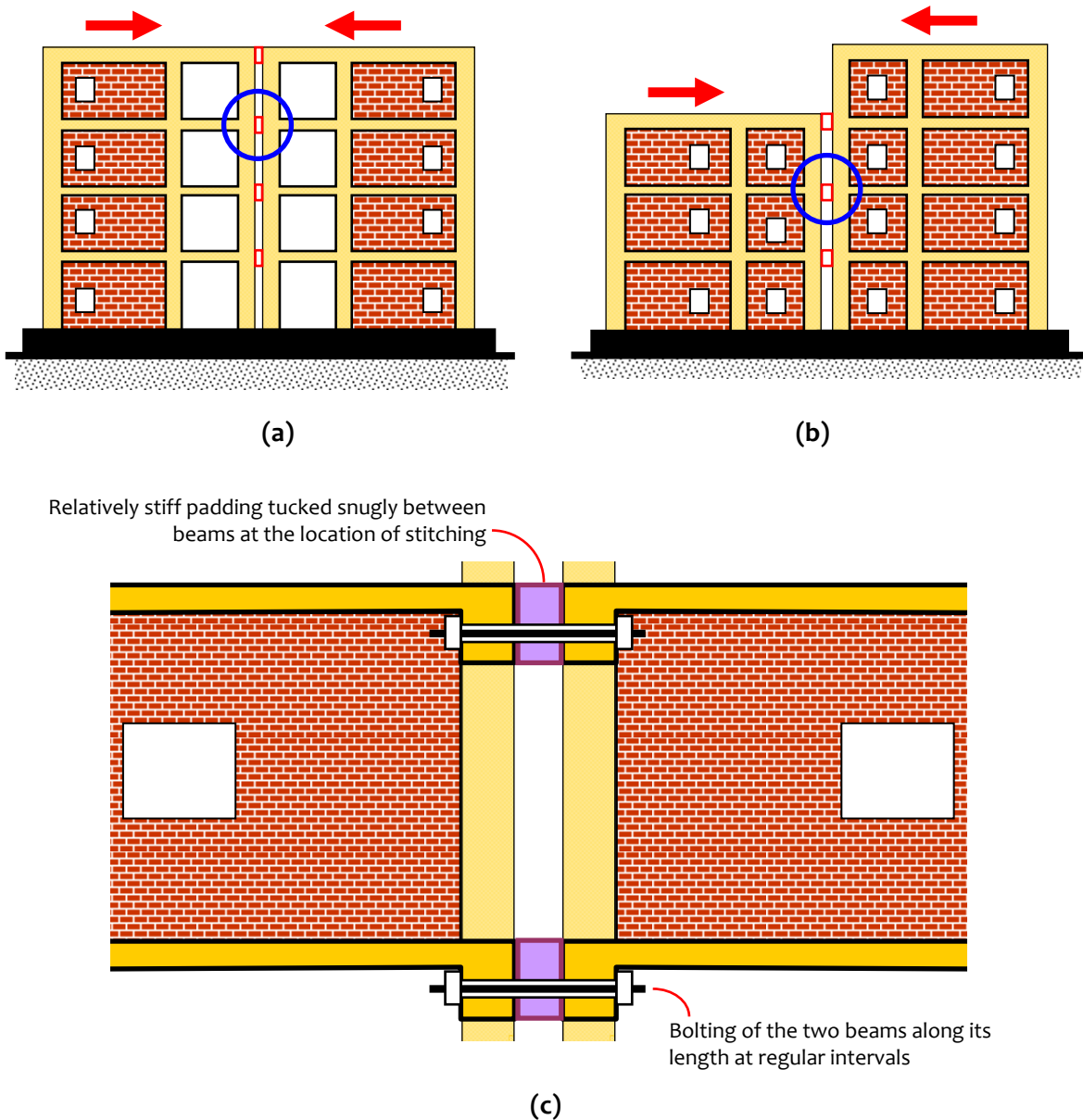


Figure 3.108: Addressing pounding when adequate separation joints cannot be provided: Beams needs to stitched of adjoining units

Consider three buildings shown in Figure 3.109. In the first case, two identical five-storey building parts with different mass (one could be finished and occupied, while the other unfinished and unoccupied) are separated by an expansion joint of 25mm. In the second case, two buildings of different height (one five-storey and another ten-storey building) with storeys at same level are close to each other. In the third case, two five storey buildings with different storey heights (and hence overall height) are one next to another. All the buildings are designed for gravity and lateral loads, and elastic dynamic analyses are done for a representative earthquake ground motion (1940 El Centro earthquake; S00E component). During the oscillation history, the buildings cross over each other implying pounding against each other (Figure 3.110). Further, out of the three cases, the case with buildings of different storey height is of most concern, because here the floors of one building hit the columns of the other and can cause failure of those columns.

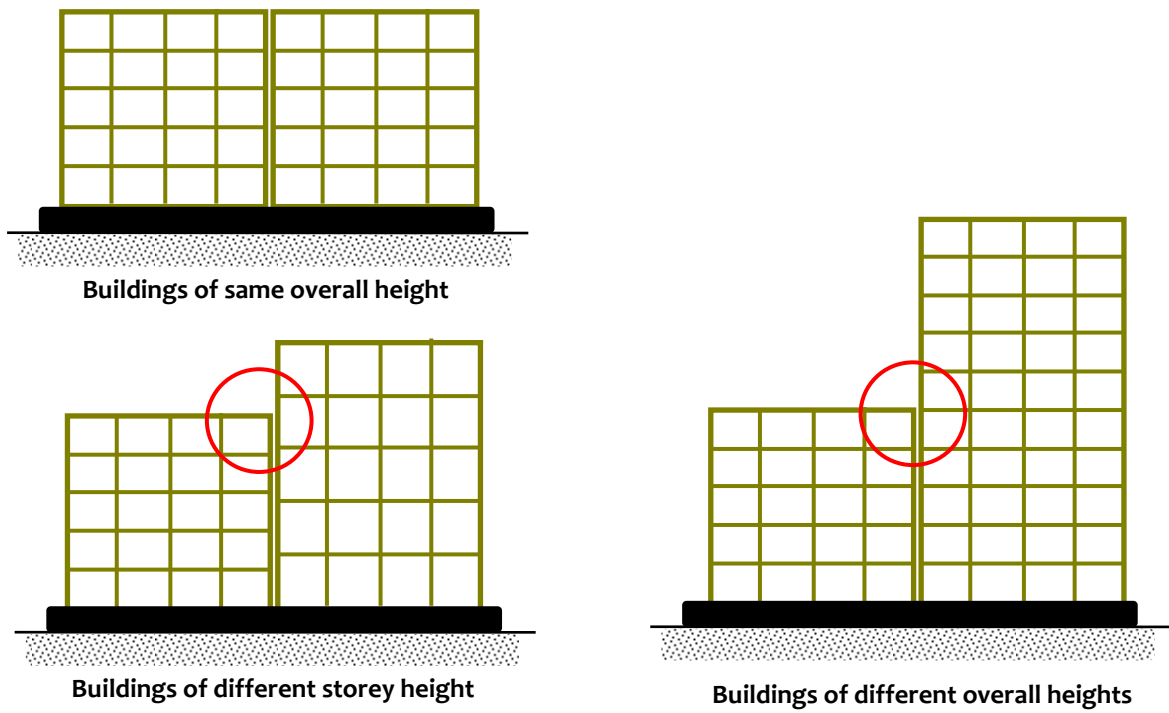


Figure 3.109: *Adjacency:* Three possibilities when adjacency of buildings can be fatal

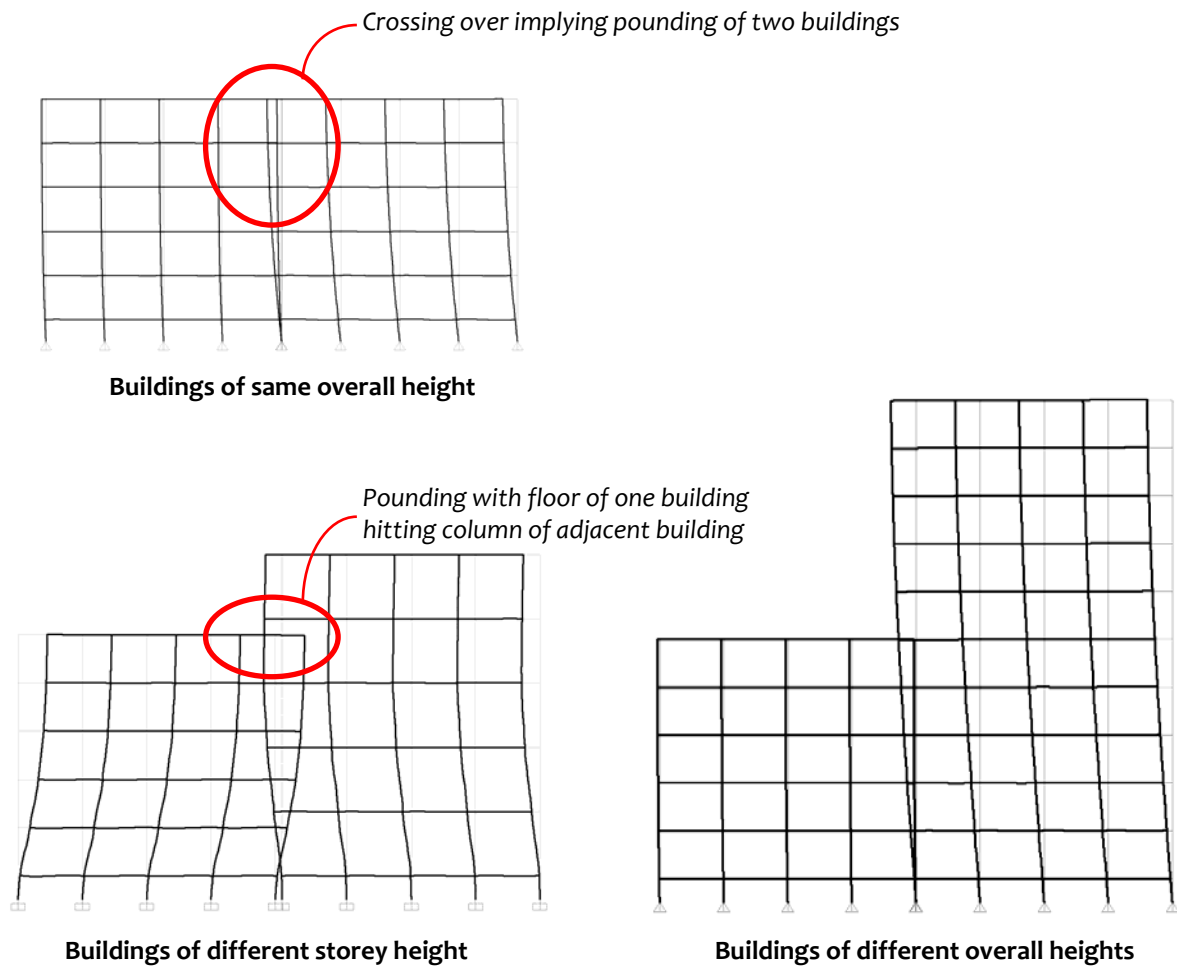
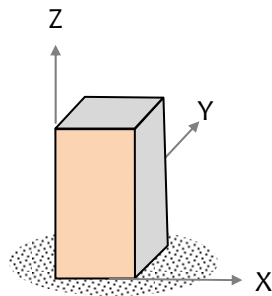
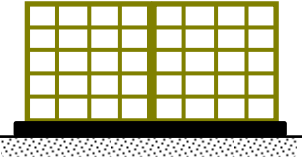
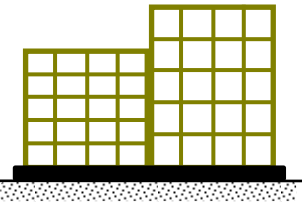
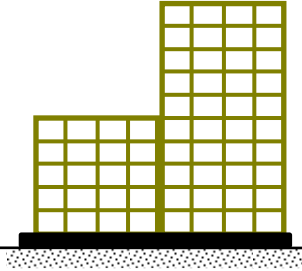


Figure 3.110: *Adjacency:* Pounding of adjacent buildings or parts should be avoided by providing adequate separation

Animation Set 319

Three-dimensional modes of buildings **Effect of Adjacency**



		
Time History Analysis	Time History Analysis	Time History Analysis
<p>Click on the 3 items above to see the deformation histories Best when viewed using Windows Media Player</p>		

3.4.4 Soil Flexibility

Flexibility of soil on which buildings are founded greatly affects earthquake behaviour of buildings. Besides, the choice of foundation system also contributes to overall response of buildings. For understanding effect of soil flexibility on earthquake behaviour of buildings, the following are considered:

- (a) Three types of soil (flexible, medium and stiff): Soil is considered to behave elastically, and its flexibility is incorporated through the *Modulus of Sub-Grade Reaction*; typical values used are listed in Table 3.16; and
- (b) Three types of foundations (isolated footings, pile and raft) (Figure 3.111): Soil is modeled as elastic springs along the length of the pile (Figure 3.112) and below the raft and footings.

The buildings considered, with the types of foundations supported on the above types of soils, have 10-stories with 4 bays in X-direction and 3 in Y-direction, each of 4m span. The member sizes are those of the benchmark building discussed in Chapter 2. When combined footings are used, the columns are constrained to deflect vertically by themselves; in such cases, the combined footing has large area over which rests on the soil. This makes the columns that are combined to behave the way they would when they are placed on a single raft. Of course, as more columns are combined, the behaviour of the building moves closer to that of a building completely rested on a raft.

Results of the analyses of these nine building-soil systems indicate that:

- (1) Buildings with isolated footings perform poorly when rested on flexible soil systems, especially in high seismic zones, and hence, should be avoided. Preferably, such buildings should be rested on raft foundations;
- (2) Columns, and the building, are close to being hinged in flexible soils at the base (Figure 3.113);
- (3) Large stresses are generated in soils at the windward and leeward edges of the building, when buildings are subjected to large lateral forces, especially when the soil is stiffer (Figure 3.114).

Table 3.16: *Soil types: Modulus of Sub-grade Reaction of different types of soil considered*

<i>Soil Type</i>	<i>Modulus of Sub-grade Reaction (kN/m³)</i>
Soft Soil	100
Medium Soil	10,000
Hard Rock	400,000

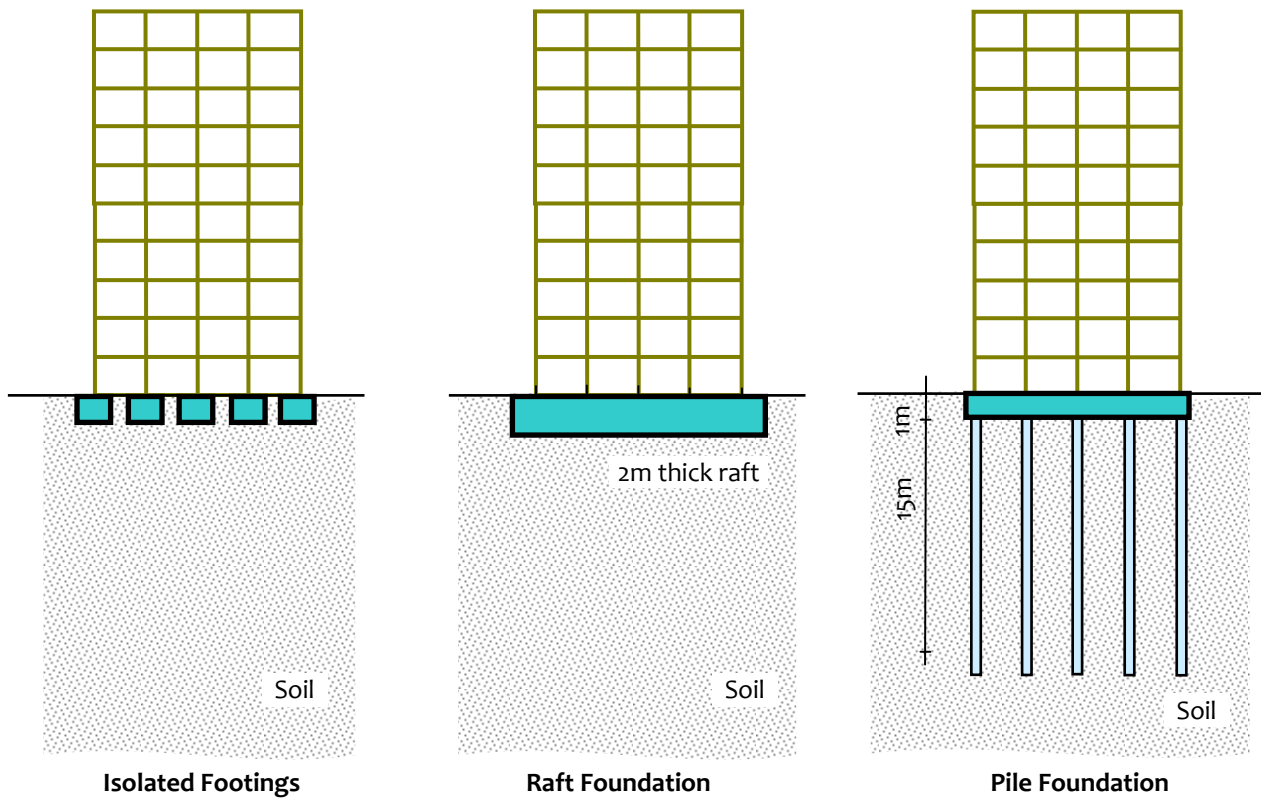


Figure 3.111: Foundation systems of buildings: Three basic types of foundations commonly used

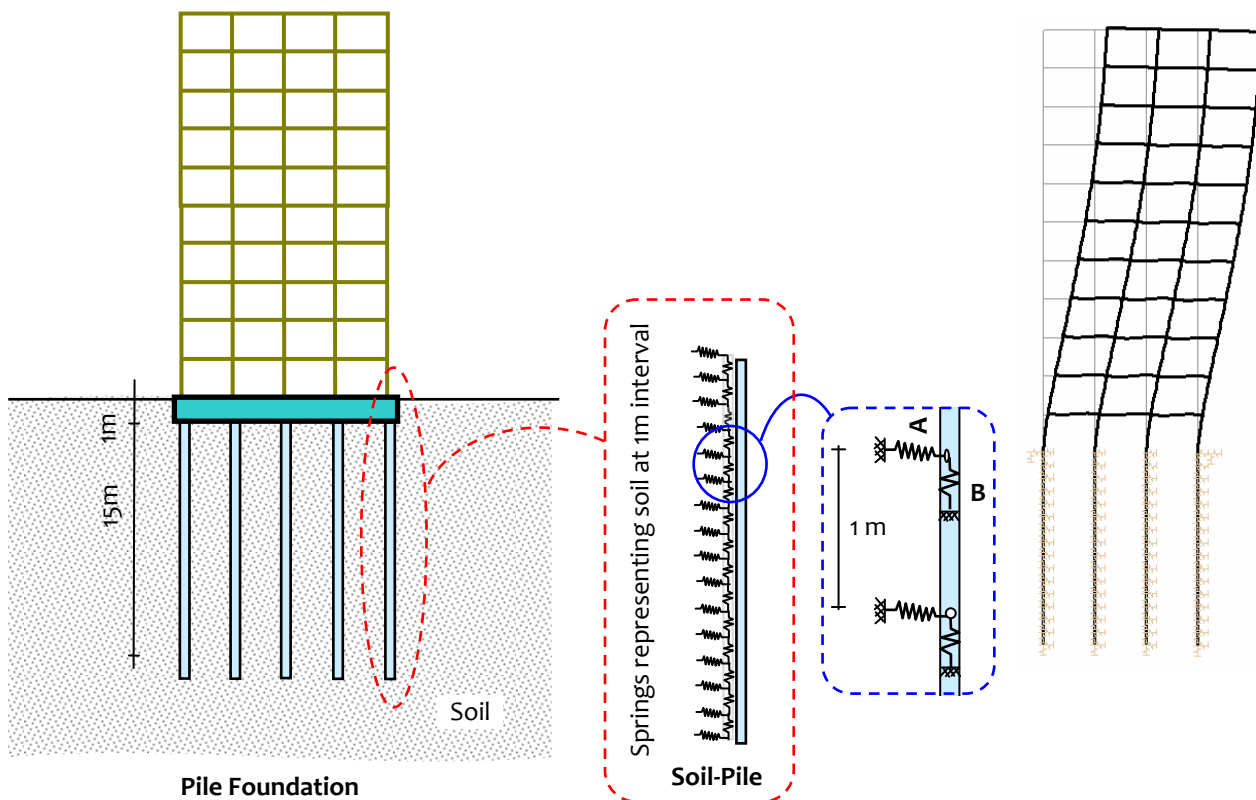


Figure 3.112: Soil-pile system in foundation of buildings: Vertical and horizontal springs are used to represent flexibility of soil in lateral and vertical directions

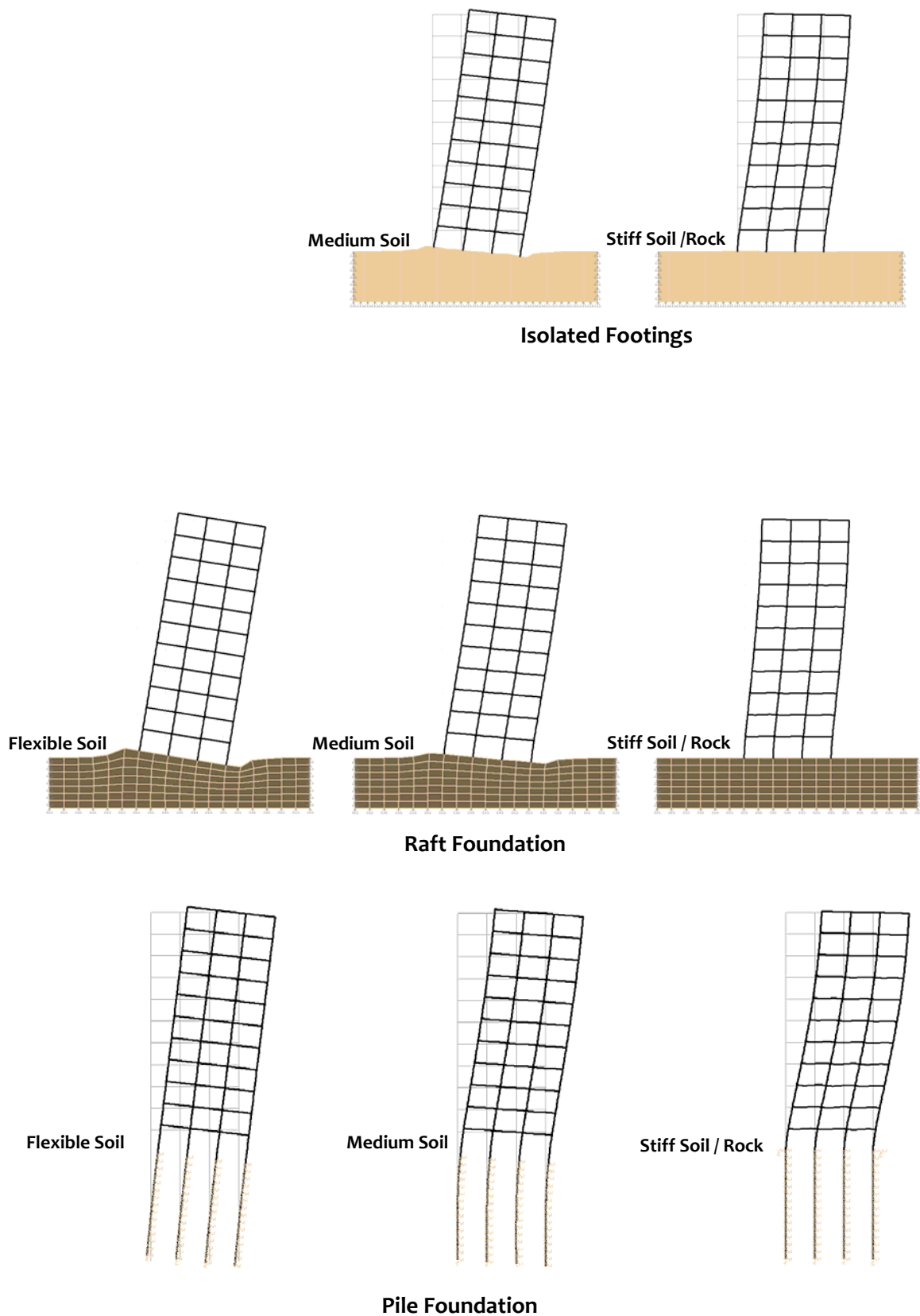
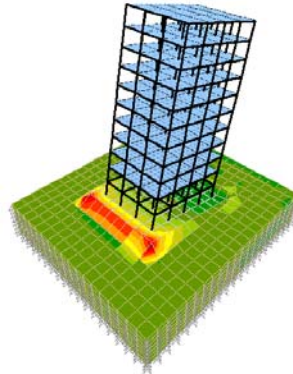
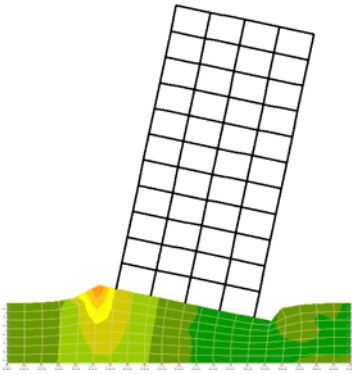
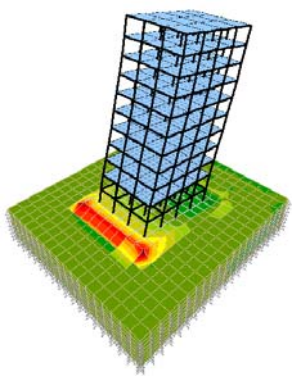
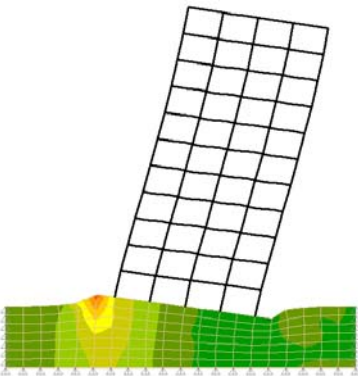


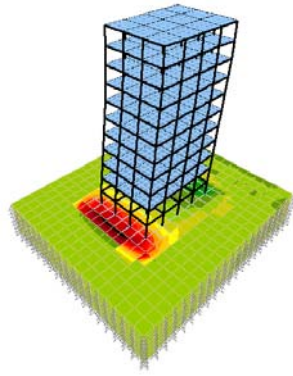
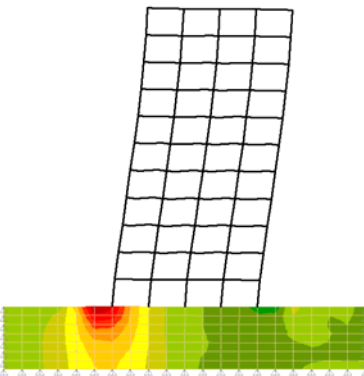
Figure 3.113: *Fundamental lateral translational mode of vibration of buildings:* Influence of soil flexibility is considerable in all three cases



Flexible Soil



Medium Soil

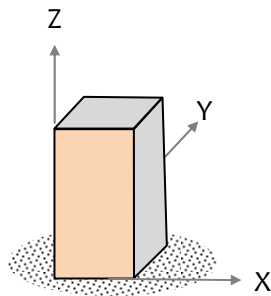


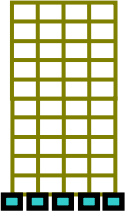
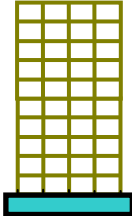
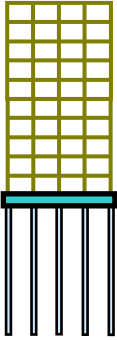
Stiff Soil / Rock

Figure 3.114: *Stress contours in Soil when building on raft loaded laterally: As soil becomes stiffer, the stresses in it increase; the deformed shape of the building changes at the base – it changes from hinged to fixed condition*

Animation Set 320

Three-dimensional modes of buildings Effect of Soil Flexibility



<p><i>Individual Footing</i></p> 	<p><i>Combined Foundation</i></p> 	<p><i>Pile Foundation</i></p> 
-	<p>FIRST Mode <u>Building on Flexible Soil</u></p>	<p>FIRST Mode <u>Building on Flexible Soil</u></p>
<p>FIRST Mode <u>Building on Medium Soil</u></p>	<p>FIRST Mode <u>Building on Medium Soil</u></p>	<p>FIRST Mode <u>Building on Medium Soil</u></p>
<p>FIRST Mode <u>Building on Stiff Soil</u></p>	<p>FIRST Mode <u>Building on Stiff Soil</u></p>	<p>FIRST Mode <u>Building on Stiff Soil</u></p>
<p><i>Click on the 8 items above to see the animation of the mode shapes</i> Best when viewed using Windows Media Player</p>		

...

Chapter 4

Earthquake Capacity of Buildings – Inelastic Behaviour

4.1 INELASTIC BEHAVIOUR

Some structural damage is allowed during strong earthquake shaking in normal buildings, even though *no collapse* must be ensured. This implies that nonlinearity will arise in the overall response of buildings, which originates from the material response being nonlinear. This nonlinearity arising from the material stress-strain curve is called *material nonlinearity*. But, sometimes, the stress-strain curve may be nonlinear and *also* elastic, whereby on unloading, the material retraces the loading path. Structural steel has definite yield behaviour and does not retrace its loading path when unloaded after yielding. Such a response is more commonly referred to as *inelastic response*. When an inelastic material is subjected to reversed cyclic loading (of displacement-type) which takes the material beyond yield, *hysteresis* takes place, *i.e.*, the material under the applied loading absorbs/dissipates energy. Reinforced concrete and structural steel are candidate materials for inelastic behaviour. Under strong earthquake shaking, normal reinforced concrete and steel buildings experience inelastic behaviour.

Inelasticity is the basis for the second two of the four virtues of earthquake-resistant buildings, namely *strength* and *ductility*. In this chapter, these are discussed to present the basic concepts related to the inelastic behaviour of buildings. It is not possible to discuss *strength* only without discussing *ductility*, and *vice-versa*. Hence, the reference of one does appear when the other is being discussed.

4.2 STRENGTH

Lateral strength of an RC building depends on many factors, including structural configuration adopted, material strengths and ductilities, relative sizes of structural members, amounts of reinforcement used in members, and strength and stiffness of joints between members. There is a complex relation between these parameters, which determines the final strength and ductility realized in the building during earthquake shaking (Figure 4.1). RC moment frames are used as the reference structural system in all discussions in this chapter also, as in Chapter 3.

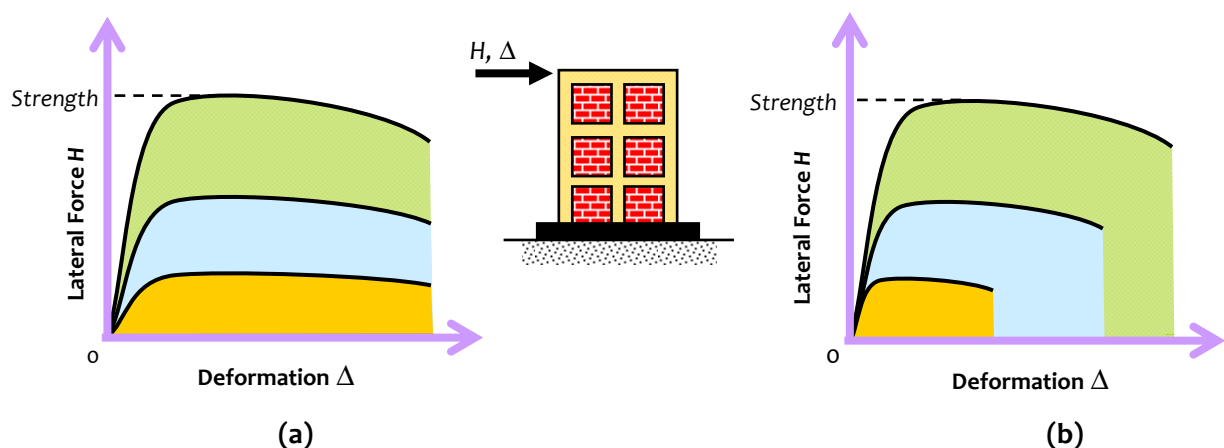


Figure 4.1: *Lateral strength of buildings:* Maximum internal resistance offered by buildings under increased displacement loading (a) Buildings having different strengths, but same ductility, and (b) Buildings having different strengths and different ductility

4.2.1 Strength Hierarchy

The load path in a moment frame building starts from the slabs, and goes along beams, beam-column joints, columns and foundations to the soil underneath. Strength hierarchy is essential along the load path, and follows the load path. Structural elements that are supporting (other structural elements and items of the buildings) are required to be stronger than those that are being supported by them. The only exceptions are the connections, especially the *beam-column joints*. Connections should be made stronger than the column members below it. This is a special situation, because in the aftermath of an earthquake, it is not easy to strengthen the beam-column joint; especially reaching its interiors is particularly difficult. And, often the damage accrued in such connections is of brittle type no matter what the material of construction is. Hence, the items to be checked in an earthquake resistant building are :

- (1) Beams stronger than adjoining braces, if any;
- (2) Beam-column joints stronger than the adjoining beams;
- (3) Columns stronger than adjoining beams;
- (4) Beam-column joint stronger than the adjoining columns;
- (5) Foundations stronger than adjoining columns; and
- (6) Soil strata underneath stronger than foundations.

The following discussion is intended to raise necessary factors that contribute to strength hierarchy.

When a multi-storey RC building is made of moment frames that are open in the ground storey to accommodate parking and infilled with masonry walls in the storeys above, all the earthquake damage occurs in the ground storey when it is not designed to resist earthquake effects (Figure 4.2a); in such cases, the ground becomes *flexible* (from point of view of stiffness) and *weak* (from point of view of strength). Most of the earthquake damage is forced into the columns of that single storey. The circles at top and bottom of columns indicate damage zones. Research has shown that the presence of compression load in columns limits their ductility. Such a building is not ductile, with damage localized in the ground storey columns alone. Such buildings should not be built in the above form. The stiffness and strength irregularity should be eliminated by choosing a structural system that does not make the irregularity so prominent. For instance, by using suitable RC structural walls that run through the full height of the building, this irregularity can be made marginal.

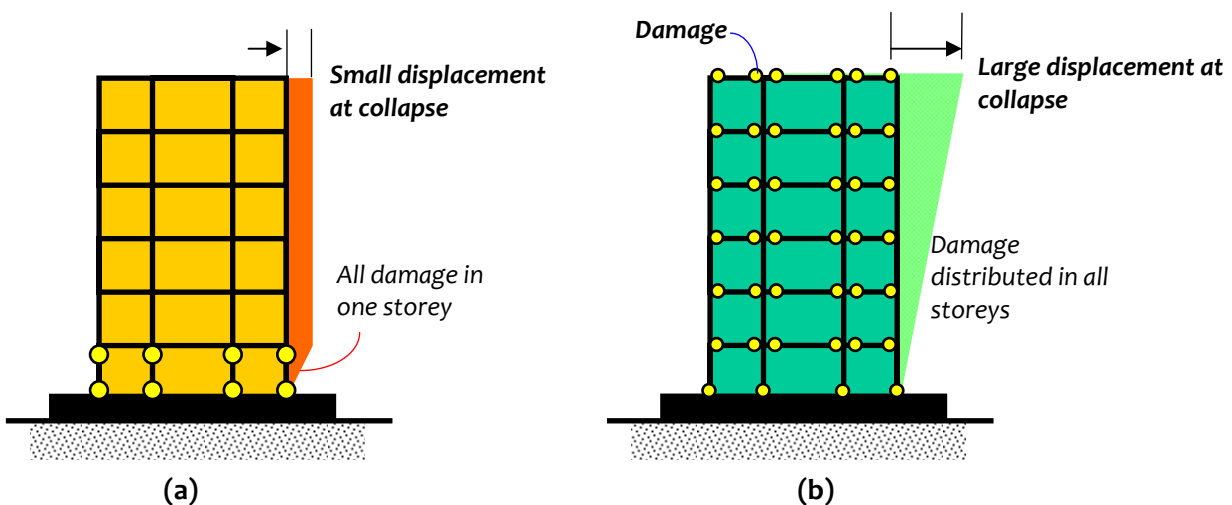


Figure 4.2: Overall collapse mechanisms of frame building: (a) Undesirable behaviour with plastic hinges only in one storey, and (b) Desirable behaviour with ductile plastic hinges in all beams

On the other hand, the ideal situation is when damage occurs at the ends of the beams and that too distributed throughout the building height (Figure 4.2b). If a beam end accrues ductile flexural damage, the beam can still carry its gravity loads easily because shear capacity is not hampered. The only damage occurring in columns is in the ground storey columns just above the foundations; there is no choice, but to accept this as an exception to the pre-requisite that no columns should sustain any damage, but after formation of ductile flexural plastic hinges at the ends of the beams distributed throughout the building height. Here, the bases of columns can be specially provided with closely spaced transverse ties to confine the concrete. The earthquake energy is dissipated now quite uniformly *throughout* the entire building rather than being *concentrated* in one floor. The building has damage of the ductile type distributed at many locations; each of these locations absorbs good amount of energy out of the input energy received from the ground. Thus, the total energy absorbed by the whole building becomes large (and of ductile type), and the building is saved from brittle collapse. Also, now energy is absorbed primarily by the beams and not the columns. This is the ideal situation because beams, with no/relatively less compression loads on them, inherently can be designed and detailed to be more ductile than columns, and absorb large amounts of energy through inelastic actions.

The combination of inelastic hinges at the ends of beams and columns, which when formed in a building eventually makes it unstable and causes its collapse, is called the *collapse mechanism*. Good ductility is achieved in a building when the collapse mechanism is of the desirable type shown in Figure 4.2b. In such a case, the hysteretic loops of its load-deformation curve are stable and full (Figure 4.3a). These type of hysteretic loops imply good energy dissipation in the building through each of the inelastic hinges at the beam ends. Such a behaviour is observed in buildings that fail in *Sway Mechanism*, which ensures that beams yield before columns, and ductile flexural damages occur at beam-ends; this happens when the building has *strong column - weak beam (SC-WB)* design (in which beams are made to be weaker in bending moment capacity and ductile links, and columns stronger in bending moment capacity) (Figure 4.4a). On the other hand, in buildings that fail in *Storey Mechanism* (Figure 4.3b), damages are concentrated in the *columns* and that too of a single storey. Here, the ductility demand on the columns is large. This situation arises when the building has *weak column - strong beam (WC-SB)* design (in which columns are weaker in bending moment capacity and beams stronger in bending moment capacity) (Figure 4.4b). This collapse mechanism dissipates less energy in the building and that too all of that energy in one storey (Figure 4.3b).

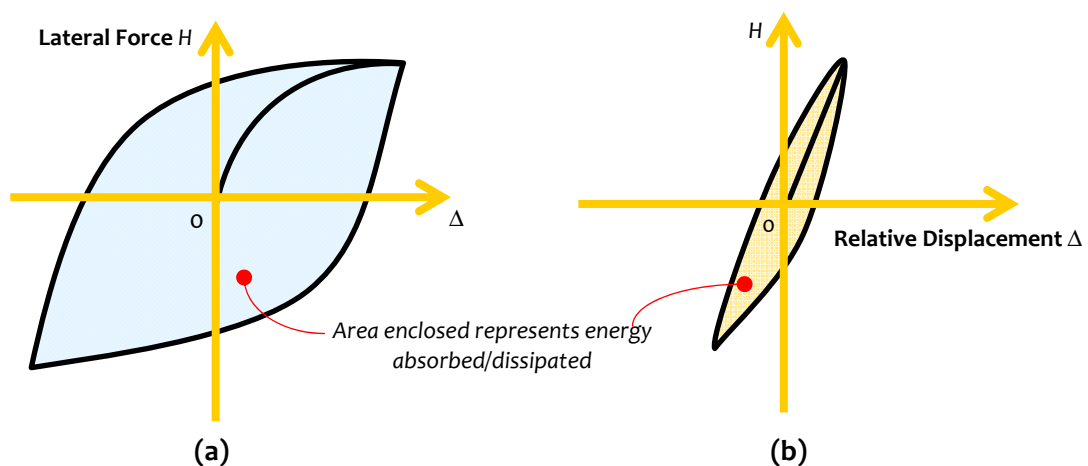


Figure 4.3: Hysteresis loop of a building: Depends on type of collapse mechanism - (a) Storey Sway Mechanism, and (b) Building Sway Mechanism

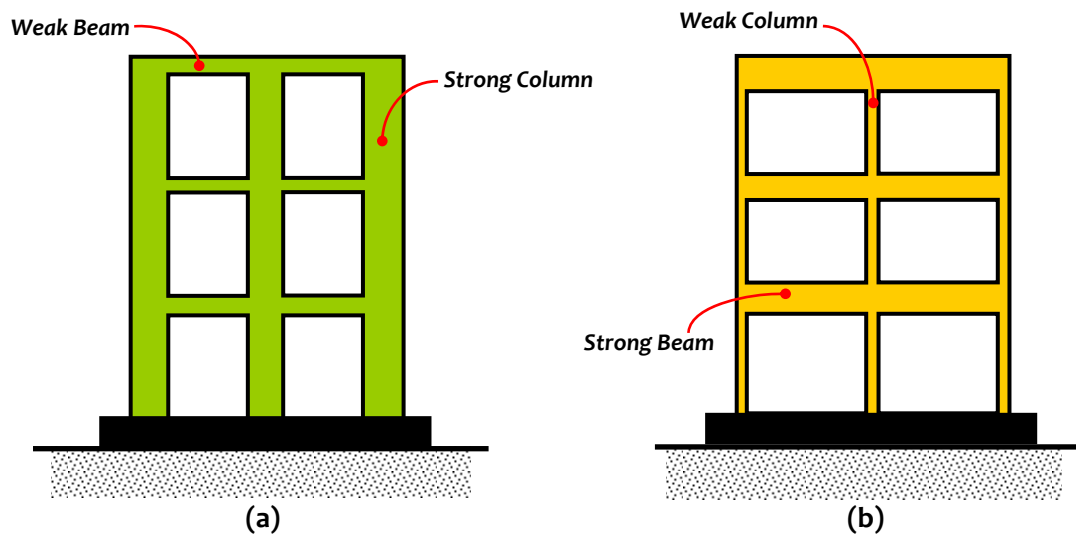


Figure 4.4: Relative proportioning of strengths of members: (a) Strong-Column Weak-Beam Design, and (b) Weak-Column Strong-Beam Design

Columns that carry large axial load normally fail in compression, by crushing of concrete under the combined action of axial force and bending moment. Thus, they undergo brittle failure. For columns to behave in a ductile manner, they need to have large axial area and their axial stress should be way below the balanced point in the P - M interaction diagram under the combined action of dead, live and earthquake loads. If such a situation cannot be ensured, collapse mechanisms of a building should be avoided which include brittle failure of columns. In normal moment frames with relatively compact column cross-sections, it becomes necessary to ensure that columns are stronger than beams (from standpoint of bending moment capacity) and no shear failure occurs either in beams or in columns, to achieve the desired ductile action in the frame (Figure 4.4). This can be achieved by (a) appropriately sizing members and providing correct amount of steel reinforcement in them, and (b) adopting capacity design principles for design of shear in both beams and columns. Such a structural configuration allows beams to dissipate large earthquake energy well before columns are damaged.

Two buildings are considered for a comparison, namely:

- (1) the benchmark 5-storey building with SC-WB design (Figure 4.5a); and
- (2) the benchmark 5-storey building with WC-SB design (Figure 4.5b).

Pushover analysis is performed of these buildings. The lateral load deformation curves of the two buildings (Figure 4.6) show that both strength and ductility of the building with SC-WB design are higher than those of the building with WC-SB design. Also, the collapse mechanism of the latter is not acceptable with columns sustaining large inelastic actions (Figure 4.7).

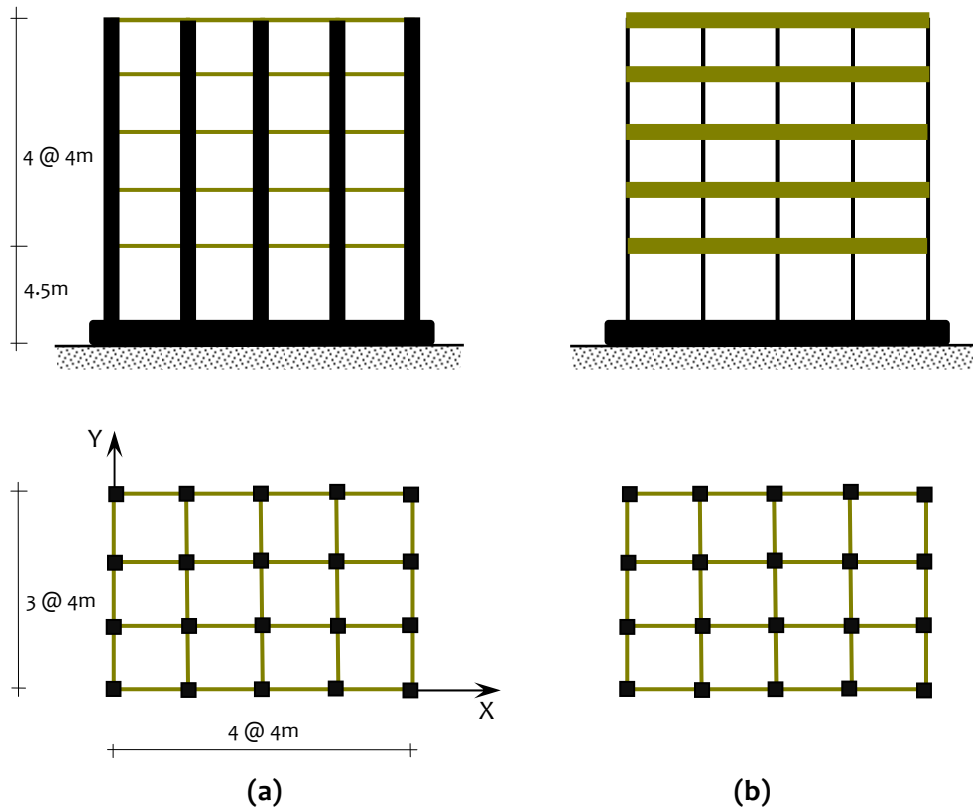


Figure 4.5: Strength hierarchy of frame members: (a) benchmark 5-storey building with SC-WB design, and (b) 5-storey building with WC-SB design

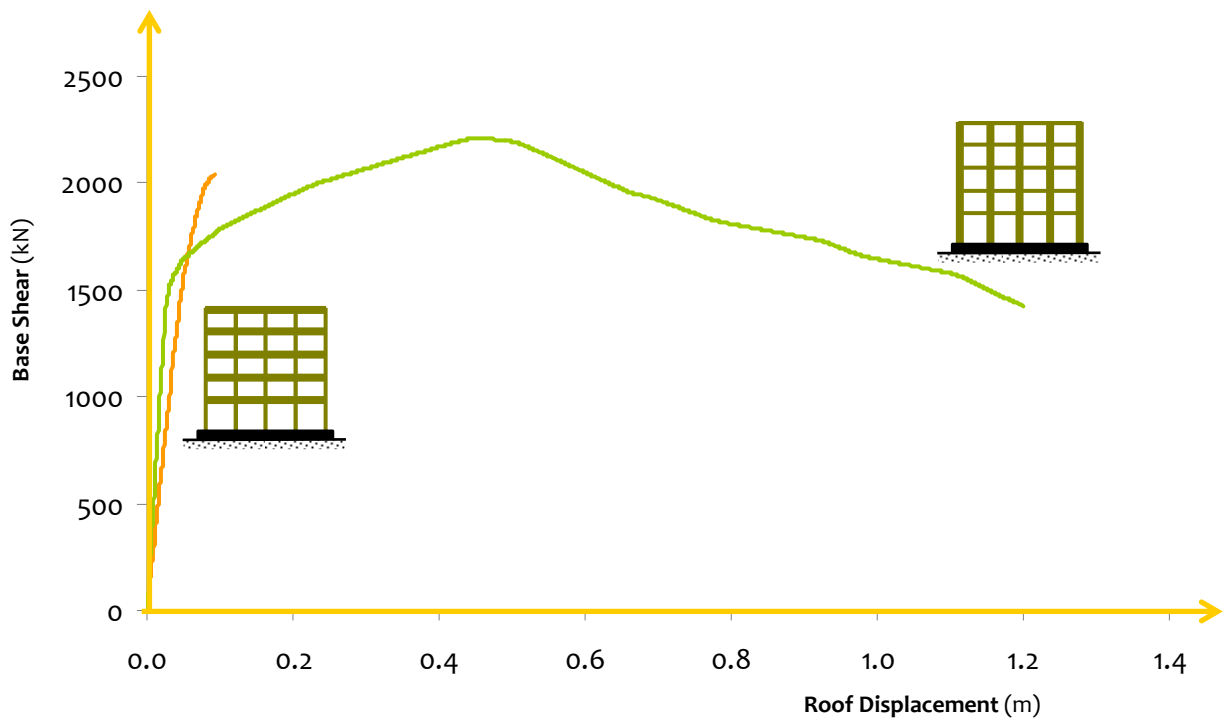


Figure 4.6: Strength hierarchy of frame members: Influence of relative strengths on overall load-deformation behaviour

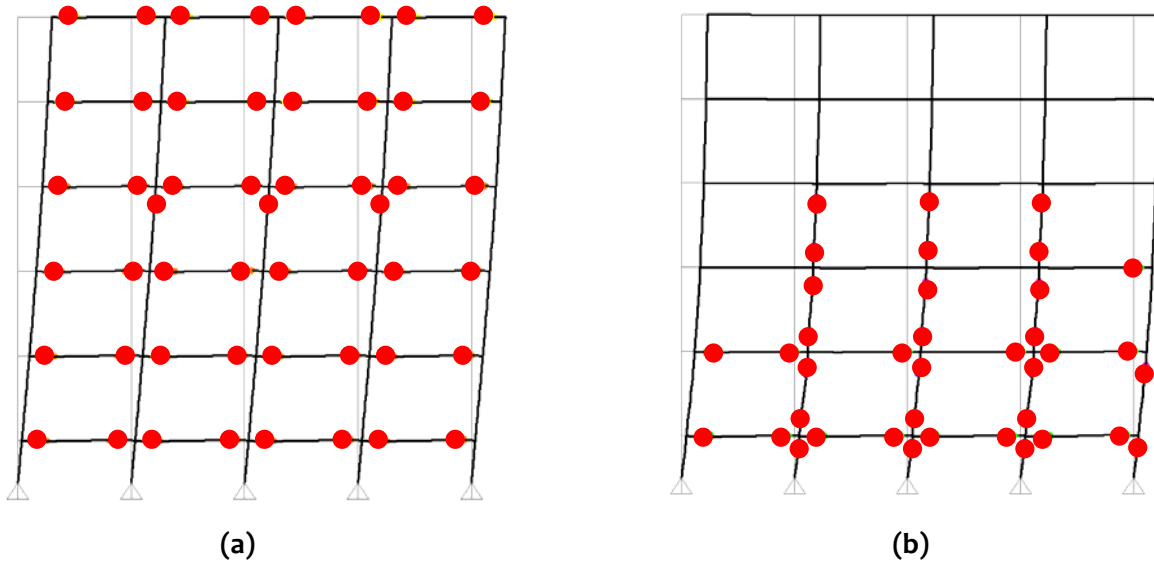
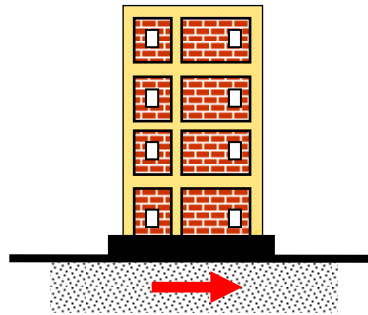
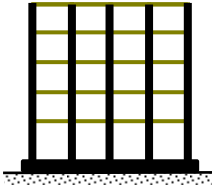
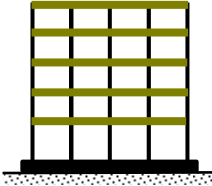


Figure 4.7: *Strength hierarchy of frame members:* Columns sustain large plastic actions when design of building follows WC-SB concept - (a) Strong column - weak beam (SC-WB) design, and (b) Weak column - strong beam (WC-SB) design

Pushover Analysis of Buildings
Effect of Strength Hierarchy



<p>Strong-column weak-beam design</p> 	<p>Weak-column strong-beam design</p> 
<p>SCWB <u>Inelasticity distributed in beams</u></p>	<p>WCSB <u>Inelasticity concentrated in columns</u></p>
<p>Click on the 2 items above to see the sequence of hinge formation Best when viewed using Windows Media Player</p>	

(a) Beam-Column Joints

Columns are critical members of buildings. Sometimes, it is not possible to eliminate damage in columns, even though of flexure under-reinforced type. In such cases, their cross-sections need to be liberally proportioned and designed, such that the combinations of design axial compressive force and bending moment sit in the lower third of their compression P - M interaction diagrams (Figure 4.8a). This is difficult to achieve, if columns have small cross-sectional areas; such columns only have marginal or no reserve moment capacities left in them beyond the capacity to resist the gravity loads safely, and hence collapse even during low intensity shaking (Figure 4.8b). Columns of narrow width have small cross-sectional areas and are under high axial stress. This results in large crack widths, which in turn results in faster ingress of moisture. Hence, the steel bars undergo corrosion at a faster pace.

Beam-column joints in moment frames are special. In RC buildings, these are portions of columns common to beams at their intersections (Figure 4.9), and are made of constituent materials that have limited strengths; hence, the joints have limited force carrying capacity. When forces larger than these are applied during earthquakes, joints are severely damaged. Repairing damaged joints is difficult, and so damage must be avoided; beam-column joints must be designed and detailed to resist earthquake effects.

Beams adjoining a joint are subjected to moments in the same (clockwise or counter-clockwise) direction under cyclic earthquake shaking (Figure 4.10). Under these moments, the top bars in the beam-column joint are pulled in one direction on one side and pushed in the same direction on the other side (Figure 4.10a). Similar is the situation in the bottom bars also with only the direction of force reversed. These forces are balanced by bond stress developed between concrete and steel in the joint region. If the column is not wide enough or if the strength of concrete in the joint is low, there is insufficient grip of concrete on the steel bars. In such circumstances, beam bars slip inside the joint region, and beams lose their capacity to carry load. Further, under the action of the above pull-push forces at top and bottom ends, joints undergo geometric distortion of the *shear-type*; one diagonal length of the joint elongates and the other compresses (Figure 4.10b). If the column cross-sectional size is insufficient, the concrete in the joint develops diagonal cracks.

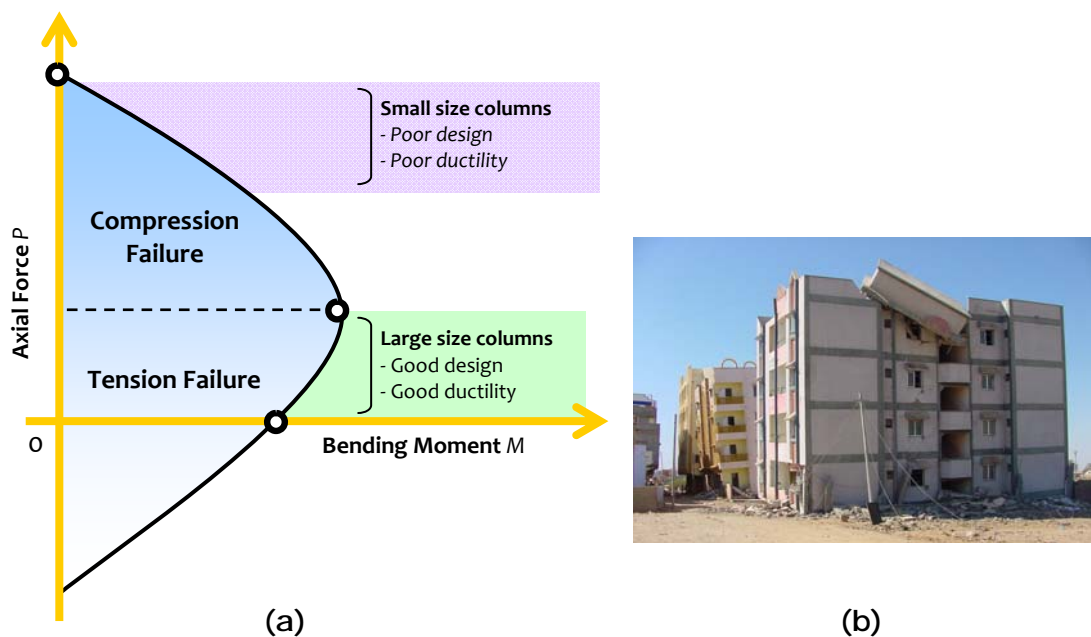


Figure 4.8: Sizing of columns in buildings: (a) Schematic of P - M Interaction diagram of RC columns, and (b) All buildings on a street lost their open ground storey during 2001 Bhuj Earthquake (India); they had small size columns (*i.e.*, 230 mm wide, 450 mm long)

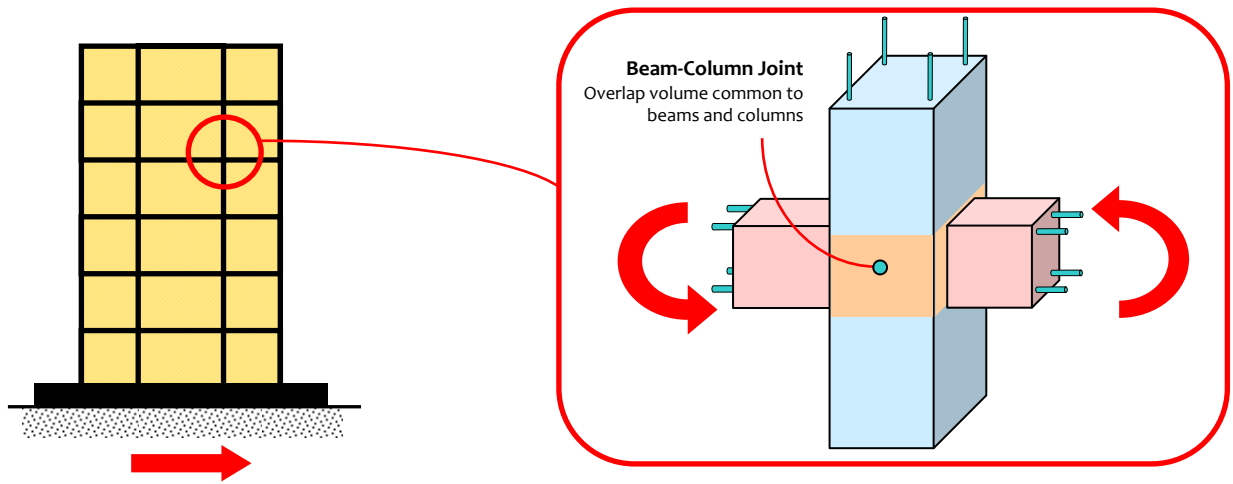


Figure 4.9: *Beam-Column Joints in Buildings:* Critical parts of a building and need to be designed

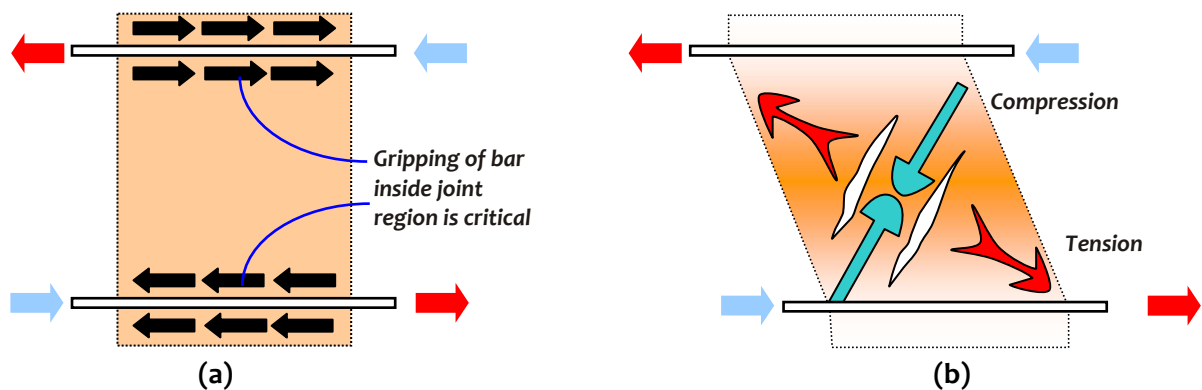


Figure 4.10: *Beam-Column Joints in Buildings:* (a) Loss of grip on beam bars in joint region; large column width and good concrete help in holding the beam bars, and (b) Distortion of joint: causes diagonal cracking and crushing of concrete

Diagonal cracking and crushing of concrete in joint region should be prevented to ensure good earthquake performance of RC frame buildings. Using large column sizes is the most effective way of achieving this. In addition, closely spaced closed-loop steel ties with 135° hooks are required around column bars (Figure 4.11) to hold together concrete in joint region and to resist shear forces. Intermediate column bars also are effective in confining the joint concrete and resisting horizontal shear forces. Providing closed-loop ties in the joint requires some extra effort. Seismic design codes recommend continuing the transverse loops around the column bars through the joint region. In practice, this can be achieved by preparing the cage of the reinforcement (both longitudinal bars and stirrups) of all beams at a floor level to be prepared on top of the beam formwork of that level and lowered into the cage (Figures 4.12a and 4.12b). Thus, the three steps are:

- (a) *Stage I:* Beam top bars are not placed, but horizontal ties in the joint region are stacked up;
- (b) *Stage II:* Top bars of the beam are inserted in the beam stirrups, and beam reinforcement cage is lowered into the formwork; and
- (c) *Stage III:* Ties in the joint region are raised to their final locations, tied with binding wire, and column ties are continued above. But, this may not always be possible, particularly when the beams are long and the entire reinforcement cage becomes heavy.

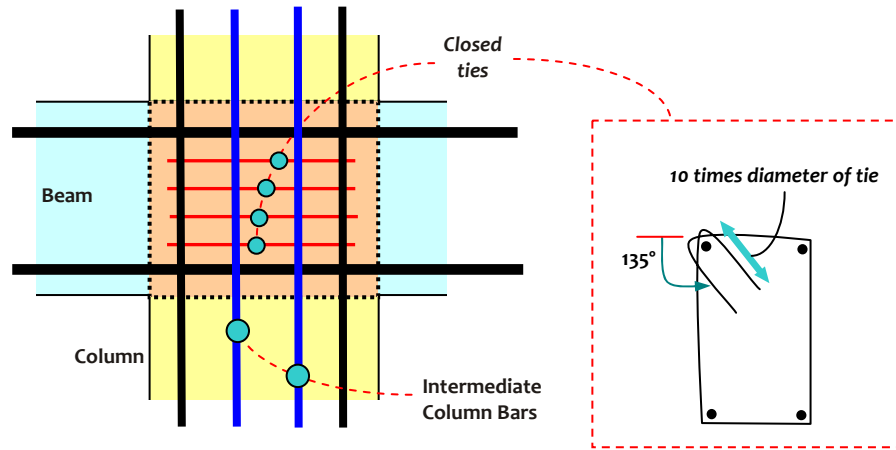


Figure 4.11: *Beam-Column Joints in Buildings:* Closed loop steel ties in beam-column joints - such ties with 135° hooks resist the ill effects of distortion of joints

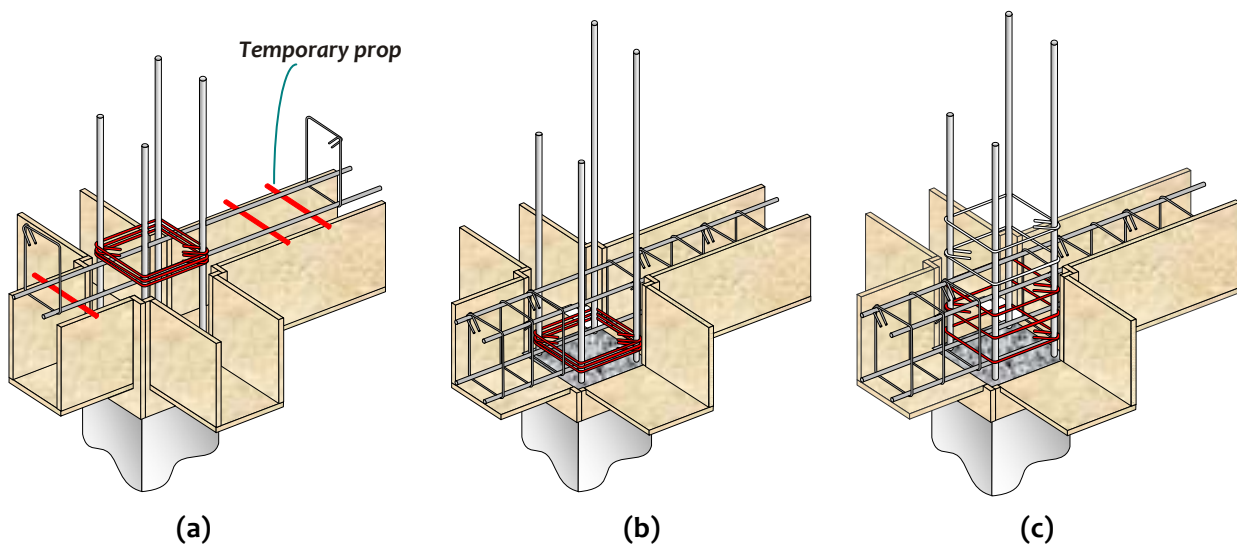


Figure 4.12: *Beam-Column Joints in Buildings:* Providing horizontal ties (a) Stage I; (b) Stage II, and (c) Stage III

Gripping of beam bars by concrete in joint region is improved first by using columns of reasonably large cross-sectional size. As explained before, some seismic design codes requires building columns in high seismic regions to be at least 300 mm wide in each direction of the cross-section when they support beams that are longer than 5 m, or when these columns are taller than 4 m between floors (or beams). ACI specifications recommend a column width of at least 20 times the diameter of largest longitudinal bar used in adjoining beam. In exterior joints, where beams terminate at columns (Figure 4.13), longitudinal beam bars need to be anchored into the column to ensure proper gripping of bar in joint. The length of anchorage for a steel bar made of grade Fe415 steel (characteristic tensile strength of 415MPa) is about 50 times its diameter; it is lower for higher grades of concrete. This length is measured from the face of the column to the end of the bar anchored in the column. In columns of small widths and when beam bars are of large diameter (Figure 4.13a), a portion of beam top bar is embedded in the column that is cast up to the soffit of the beam, and a part of it overhangs. It is difficult to hold such an overhanging beam top bar in position while casting the column up to the soffit of the beam. Moreover, the vertical distance beyond the 90° bend in beam bars is not very effective in providing anchorage. On the other hand, if column width is large, beam bars may not extend below soffit of the beam (Figure 4.13b). Thus, it is preferable to have columns with sufficient width. Such an approach is used in many codes. In interior joints, beam bars (both top and bottom) need to go through the joint without any cut in the joint region. Also, these bars must be placed within the column bars and with no bends (Figure 4.14).

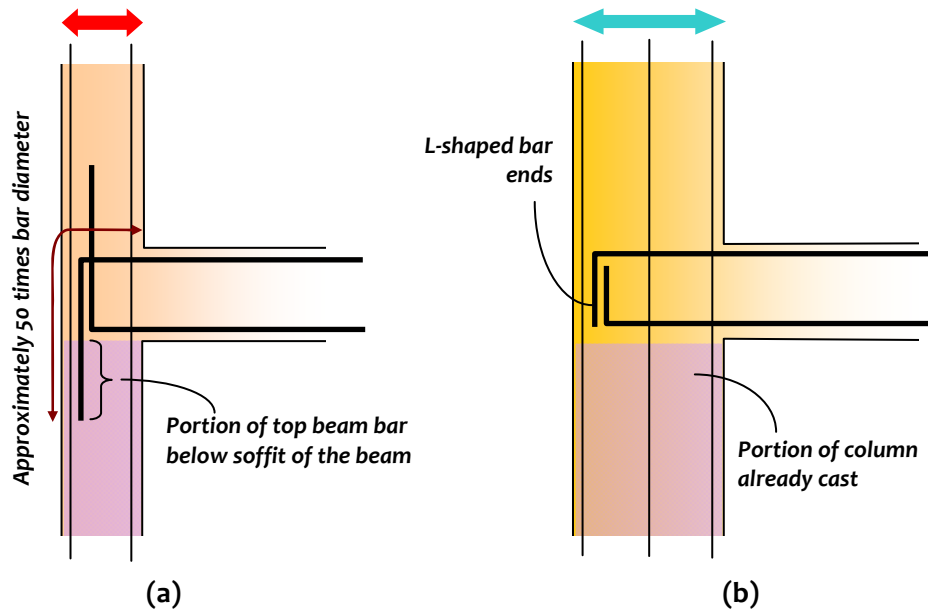


Figure 4.13: *Beam-Column Joints in Buildings:* Anchorage of beam bars in exterior joints: diagrams show elevation of joint region - (a) poor practice, and (b) good practice

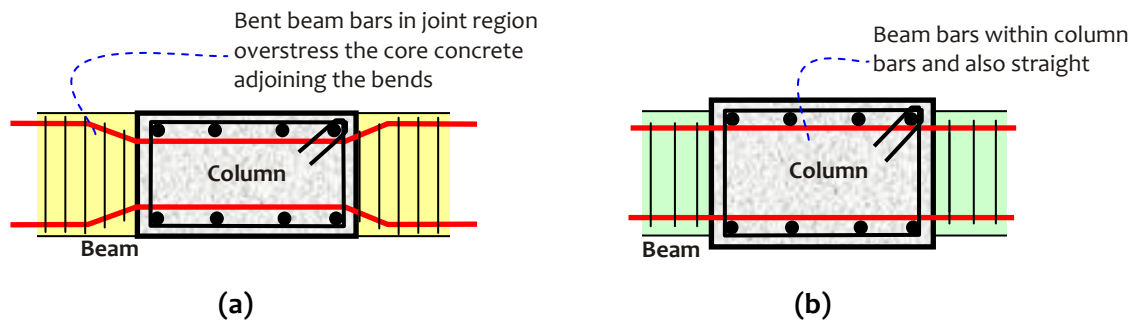


Figure 4.14: *Anchorage of beam bars in interior joints:* diagrams show cross-sectional views in plan of joint region - (a) poor practice to bend bars in the joint region, and (b) good practice to use wider column and not bend bars in the joint region

4.2.2 Structural Plan Density

The area of vertical members of a building has been reduced drastically from about 50-60% of the plinth area in historic masonry buildings to a meager 2-4% in modern RC frame buildings. This sharp reduction was possible by the advent of materials whose strength and stiffness properties are at least one order of magnitude higher. This ratio of the area of footprint of vertical elements resisting the lateral load and the plinth area of the building is called *Structural Plan Density* (SPD) of the building. SPD is low for *gravity only design* of buildings (usually around 2% or lesser) and increases for *gravity plus lateral load design* of buildings (to about 4% or more). SPD can be taken as a measure to reflect the overall earthquake performance of the building. Higher area of vertical members is necessary in buildings meant to be earthquake-resistant.

The current level of SPD in RC moment frame buildings being built in India is insufficient as demonstrated during many earthquakes in the past. Columns sizes have to be larger to be able to ensure that they do not fail in a brittle manner in compression and shear with no ductility in them. In RC moment frame buildings (Figure 4.15a), there are many beams and columns to rely on to develop ductility. Also, there are a number of joints between beams and columns, which can be inefficient in transferring the forces between them, if not designed, detailed and constructed properly. As discussed earlier, there are a number of fine details in the design and detailing of RC columns and beam-column joints.

One efficient alternative way of improving seismic performance of RC buildings is by introducing structural walls in them (Figure 4.15b). RC walls can be built in *select* bays but running through the full-height of the building; the other bays can be infilled with masonry walls or left open. Two advantages arise out of use of structural walls in RC buildings. Firstly, such buildings have large initial stiffness, which reduces the lateral deflection and hence damage under earthquake shaking of low intensity. Secondly, walls, being stiffer than moment frames, attract more earthquake force towards themselves. This facilitates moment frames to be lightly reinforced, which makes buildings with structural walls more economical and easy to construct, than buildings with only moment frames without structural walls. Mark Fintel, noted earthquake engineer in USA, once remarked that *there is no known collapse of buildings designed with structural walls meant to resist the effects of earthquakes*. This remark, though compelling, aptly summarises the effectiveness and role of structural walls in earthquake resistant RC buildings.

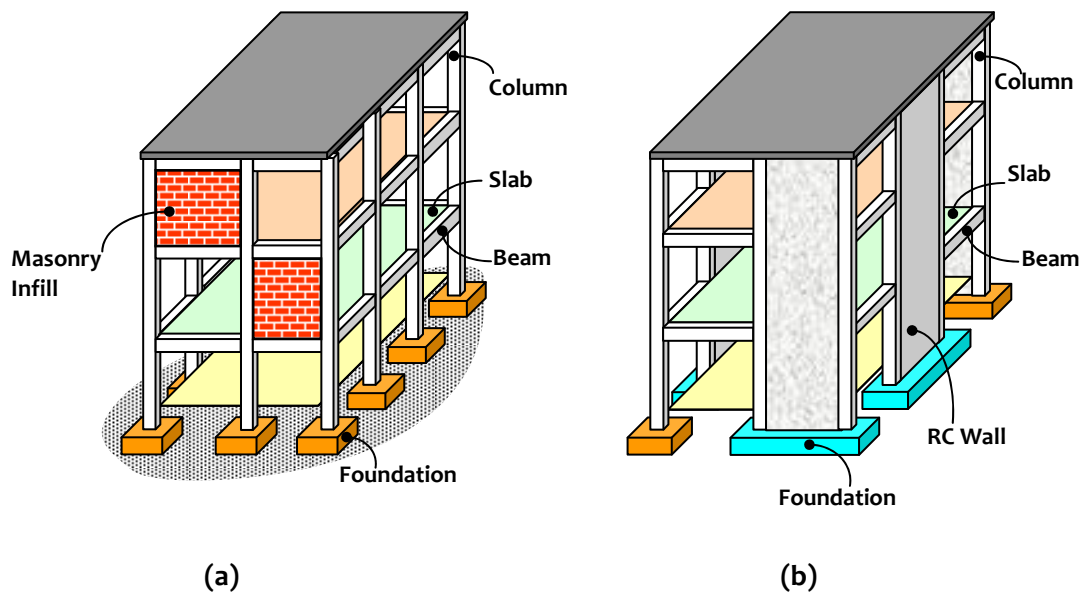


Figure 4.15: Use of Structural Walls in buildings: Walls of full-height provide a reasonably uniform stiffness and strength along the height: (a) Moment-frame building, and (b) Moment-frame building with Structural Walls

Six buildings are considered for comparison, namely:

- (1) The benchmark 5-storey building with columns of size 400mm×400mm (Figure 4.16a);
 - (2) Similar 5-storey building with columns of size 500mm×500mm (Figure 4.16b);
 - (3) Similar 5-storey building with columns of size 600mm×600mm (Figure 4.16c);
 - (4) Similar 5-storey building with structural walls introduced in 2 bays along X-direction (Figure 4.16d);
 - (5) Similar 5-storey building with structural walls introduced in 4 bays along X-direction (Figure 4.16e);
- and

(6) Similar 5-storey building with structural walls introduced in 8 bays along X-direction (Figure 4.16f). All walls are 250 mm thick and extend through the full-height of the building. Pushover analysis is performed of these six buildings. Monitoring the bending moments in an interior column of these buildings (Figure 4.17) suggests that strength demand on them reduces drastically when additional walls are provided; as cross-sectional area of walls increases, the moment demand drops. But, on the other hand, the moment demand increases when columns alone are used and their cross-sectional area is increased. In either case (*i.e.*, additional walls are used or larger columns are used), the SPD increases. Reducing the moment demand on columns by the use of structural walls implies lesser reinforcement in the frame columns and hence an overall economical design. Thus, increasing the SPD by the use of walls is definitely more beneficial.

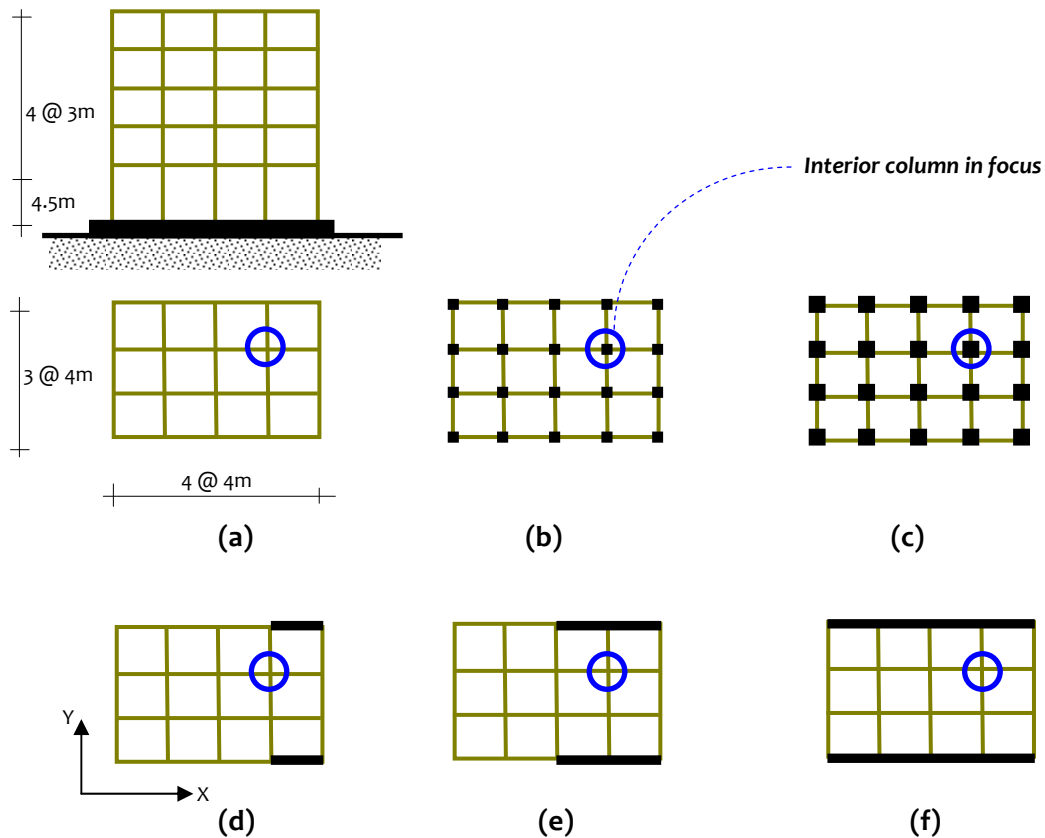


Figure 4.16: Strength hierarchy of frame members: (a) benchmark 5-storey building with 400mm×400mm columns; (b) similar 5-storey building with 500mm×500mm columns; (c) similar 5-storey building with 600mm×600mm columns; (d) similar 5-storey building with structural walls in 2 bays; (e) similar 5-storey building with structural walls in 4 bays; (f) similar 5-storey building with structural walls in 8 bays

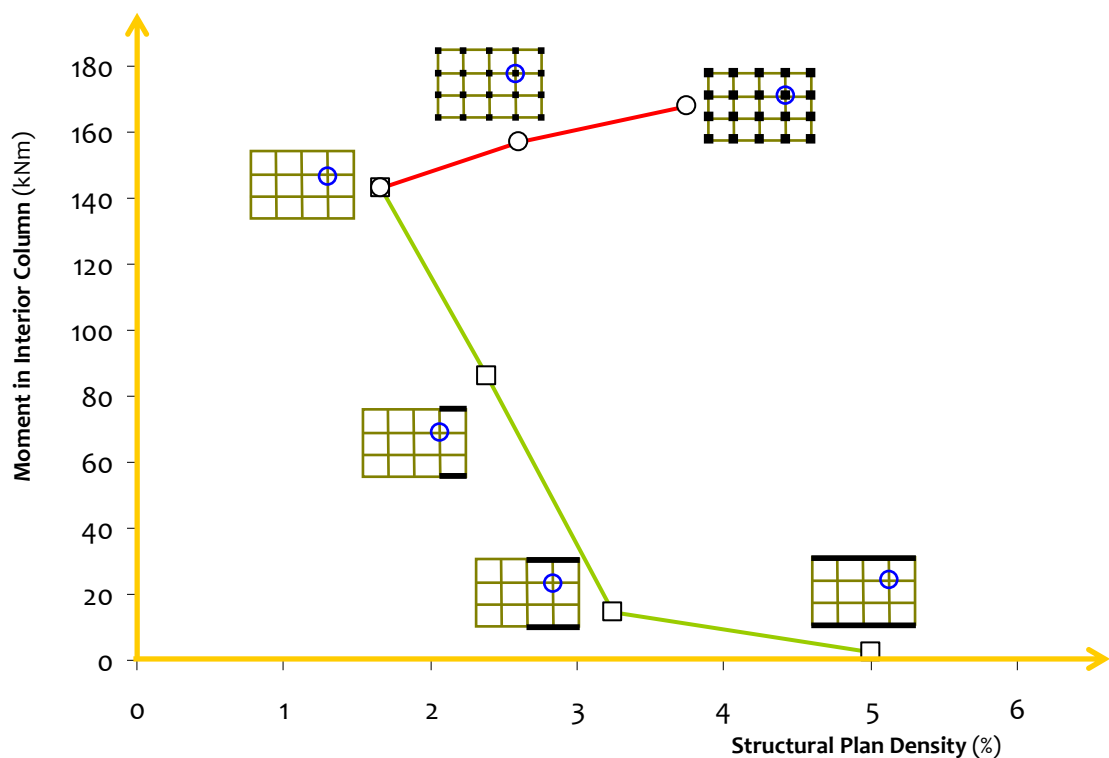


Figure 4.17: Structural Plan Density of vertical members in buildings: For the same area of vertical members (SPD), buildings tend to be more economic when structural walls are used, as against when columns of larger cross-sectional areas are used

4.2.3 Strength Asymmetry in Plan

When center of mass (CM) and center of stiffness (CS) of a building do not coincide in plan at any floor level, the building twists about an axis parallel to its vertical axis. This behaviour is observed under *elastic* conditions of the building. A similar aspect of inelastic behaviour is related to the *strength* of the building, but under *inelastic* conditions. Typically, in an elastically symmetric building, the stiffness and mass are symmetrically placed in plan. But, if the RC columns/vertical elements have unequal reinforcement, influence of this is felt only when columns reach their strength limits, especially the weaker columns. Here, once weaker columns reach their strength limit, stiffness deteriorates in those columns. This results in a stiffness asymmetry that did not exist before during elastic behaviour. Thus, CM and CS do not coincide once inelasticity begins.

There are two effects of this strength asymmetry (Figure 4.18), namely (a) onset of torsional response in the building, and (b) excessive deformation demand on few members, especially the weaker columns. This behaviour is prominent when shaking is strong and difference in strengths is large between vertical members on either side in plan. Moreover, the second effect of excessive deformation demand depends strongly on the ratio of the *fundamental torsional natural period* to *fundamental lateral natural period* of the building, and the type of shaking. These observations may not be so obvious, if the strength variation is randomly distributed in the plan of the building.

Two buildings are considered for comparison, namely:

- (1) the benchmark 5-storey building *with columns having uniform lateral strength* (Figure 4.19a); and
 - (2) the 5-storey building of same geometry and structural grid *with columns on in two frame lines having larger lateral strength*, but the average strength of columns along any frame line is the same as that of the columns along the same frame line in the benchmark building (Figure 4.19b);
- Pushover analysis is performed of these buildings. The lateral strengths of the two buildings is different; the overall lateral strength of the building with strength asymmetry is larger than that of the benchmark building (Figure 4.20). But, the inelastic deformed shape of the building shows that the building with strength asymmetry undergoes inelasticity in the columns of the stronger frames of the building (Figure 4.21c). The frames with weaker columns do not sustain this undesirable behaviour (Figure 4.21b).

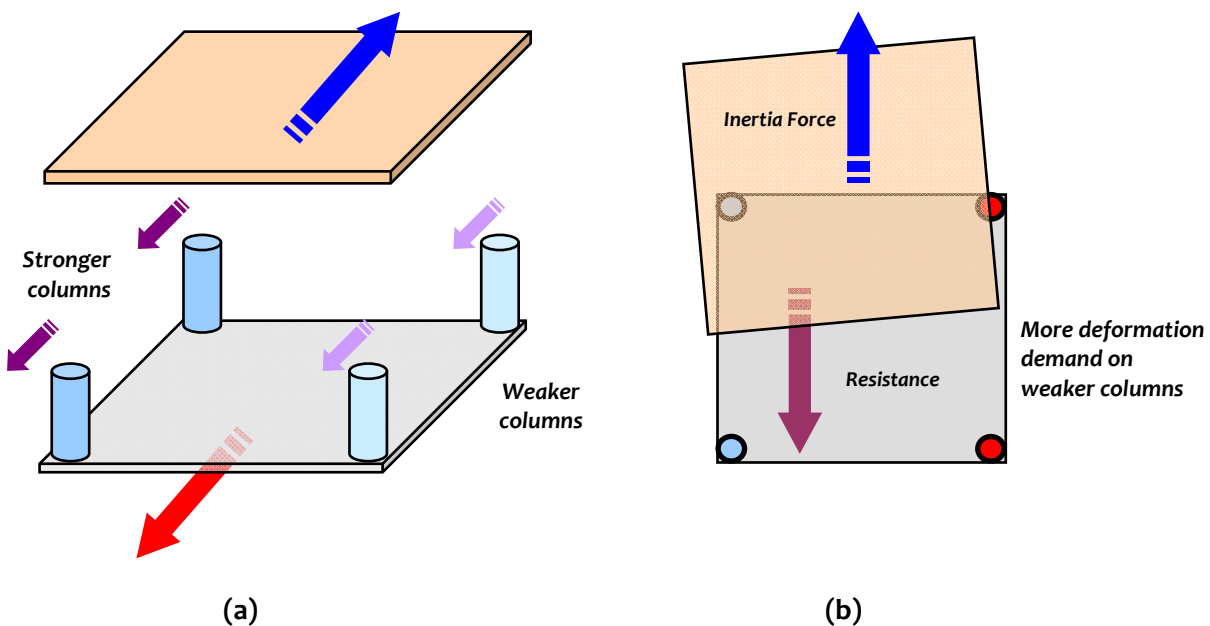


Figure 4.18: Lateral strength asymmetry in plan of a building: Lateral load resisting elements are critical in controlling earthquake behaviour of buildings – (a) four-column building has no stiffness and mass asymmetry so long as the behaviour is purely elastic, but (b) develops stiffness asymmetry at the onset of inelasticity in the weaker members

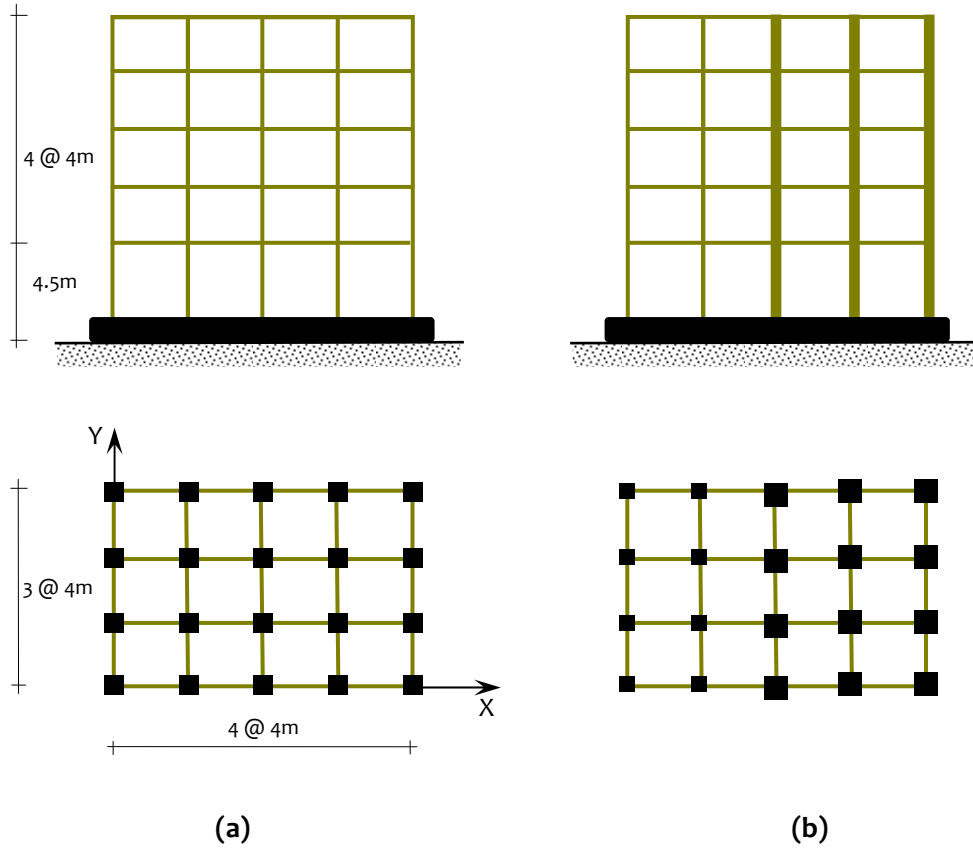


Figure 4.19: Lateral strength asymmetry in plan of building: (a) Benchmark 5-storey building with columns of uniform strength; and (b) Similar 5-storey building, but with asymmetry in column strengths in plan

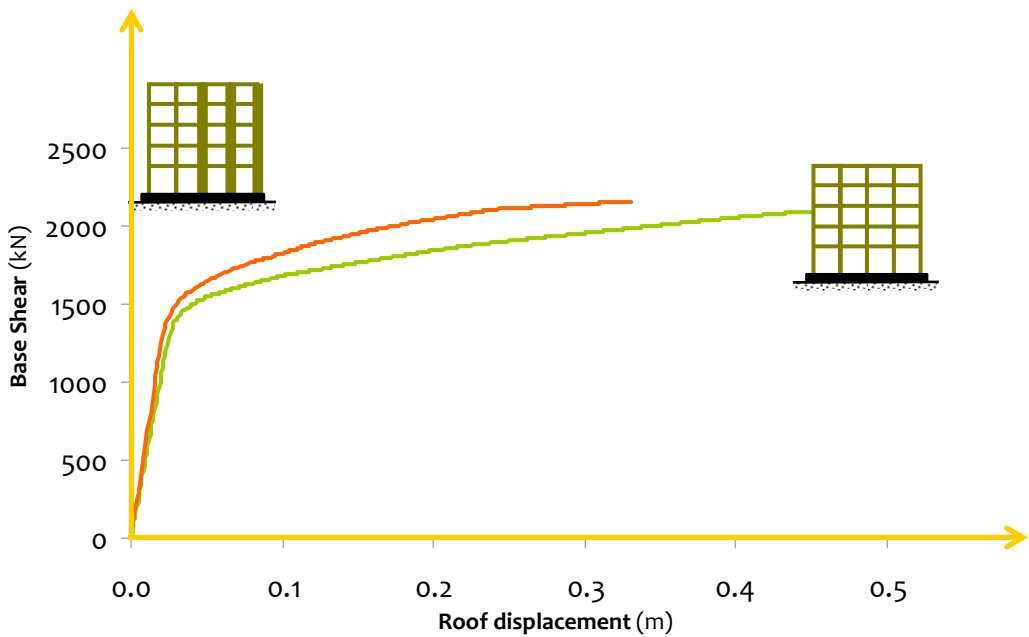


Figure 4.20: Lateral strength asymmetry in plan of building: Strength asymmetry has detrimental effect on building with lateral strength asymmetry

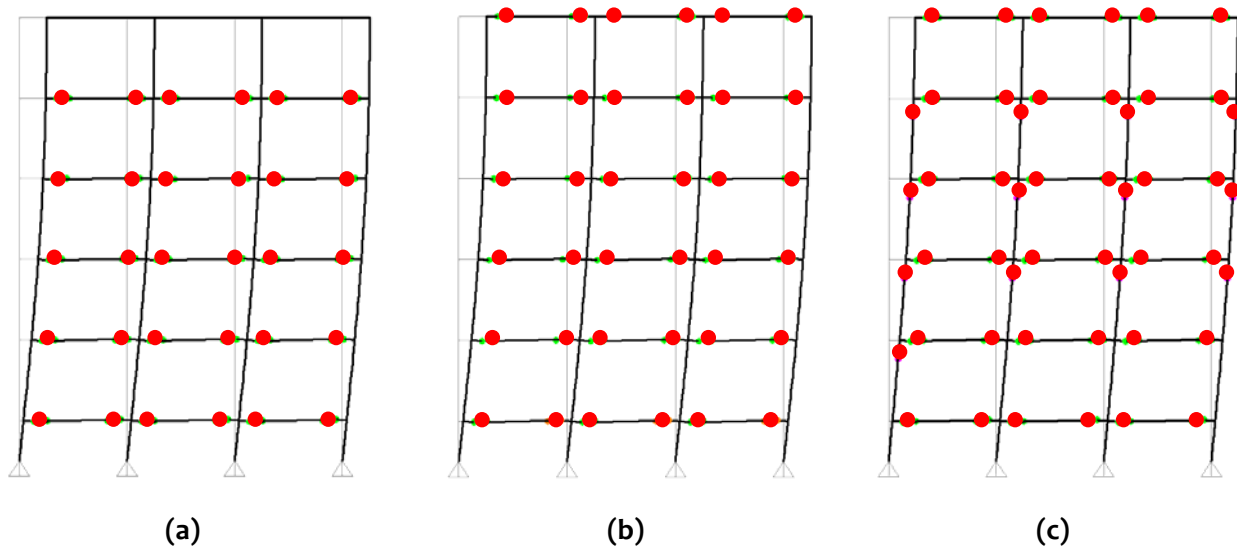
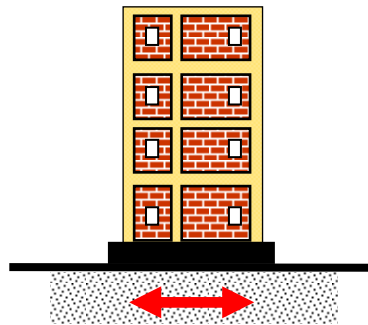
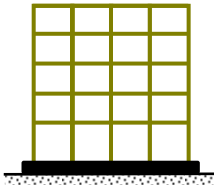
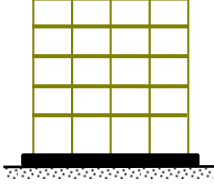
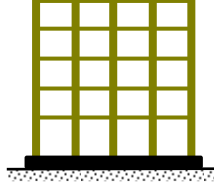


Figure 4.21: *Lateral strength asymmetry in plan of building:* Strength-asymmetric buildings attract more demand on stronger columns and undergo undesirable column inelasticity - (a) frame in benchmark building with damage in *beams*, (b) strength asymmetry building frames with weaker columns sustain damage in *beams*, and (c) strength asymmetry building frames with stronger columns sustain damage in *columns*

Pushover Analysis of Buildings
Effect of Strength Irregularity in Plan



<p><i>Regular Frame</i></p> 	<p><i>Frame with Weaker Columns</i></p> 	<p><i>Frame with Stronger Columns</i></p> 
<p><u>Inelasticity distributed in beams</u></p>	<p><u>Inelasticity distributed in beams</u></p>	<p><u>Inelasticity in columns</u></p>
<p>Click on the 3 items above to see the sequence of hinge formation Best when viewed using Windows Media Player</p>		

4.2.4 Strength Discontinuity in Elevation

Strength discontinuity or sudden reduction in lateral strength of the building is more serious when along the height of the building than in plan (also see Section 3.4.2). This discontinuity or reduction causes large inelastic demand at the junctions where this discontinuity or reduction is present. Performances during past earthquakes have shown *time and again* how sudden changes in configuration leads to concentration of damage and ductility demand in a few adjoining regions (Figure 4.22); in particular, locally flexible and weak regions suffer severe damage. Earthquake-resistant design avoids such situations of poor seismic structural configuration. One way of identifying this problem is by performing the inelastic pushover analysis of the building after designing it for the prescribed load combinations.

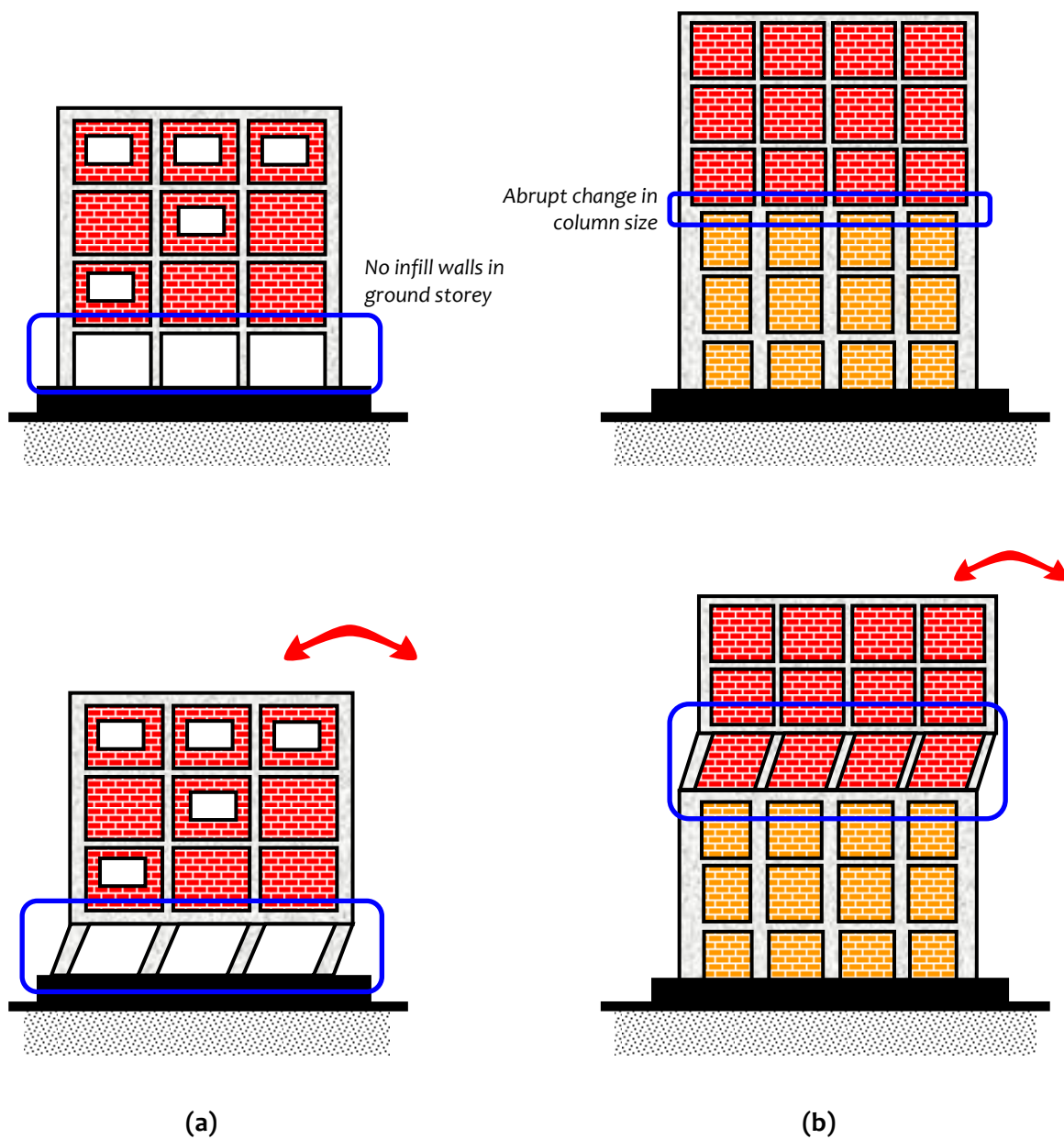


Figure 4.22: Lateral strength discontinuity or reduction of lateral strength along height of building: Strength reduction affects inertia force transfer – (a) open storey, and (b) change in member sizes

The first step is to assess storey stiffness and strength by performing inelastic pushover analysis of each storey in the building. This can be done sequentially, as shown in Figure 4.23 for a three storey building. Each floor is constrained from lateral translation and the floor above is subjected to displacement-controlled push in the lateral direction. Indian seismic code recommend that for a building to be deemed regular, lateral *stiffness* in any storey should not be less than 70 percent of that in the storey above, or less than 80 percent of the average lateral stiffness of three storeys above it, and lateral *strength* in any storey should not be less than 80 percent of that of the storey above. The distribution of lateral strength and stiffness along the building height needs to be determined to identify any irregularity in lateral strength or stiffness (Figure 4.24).

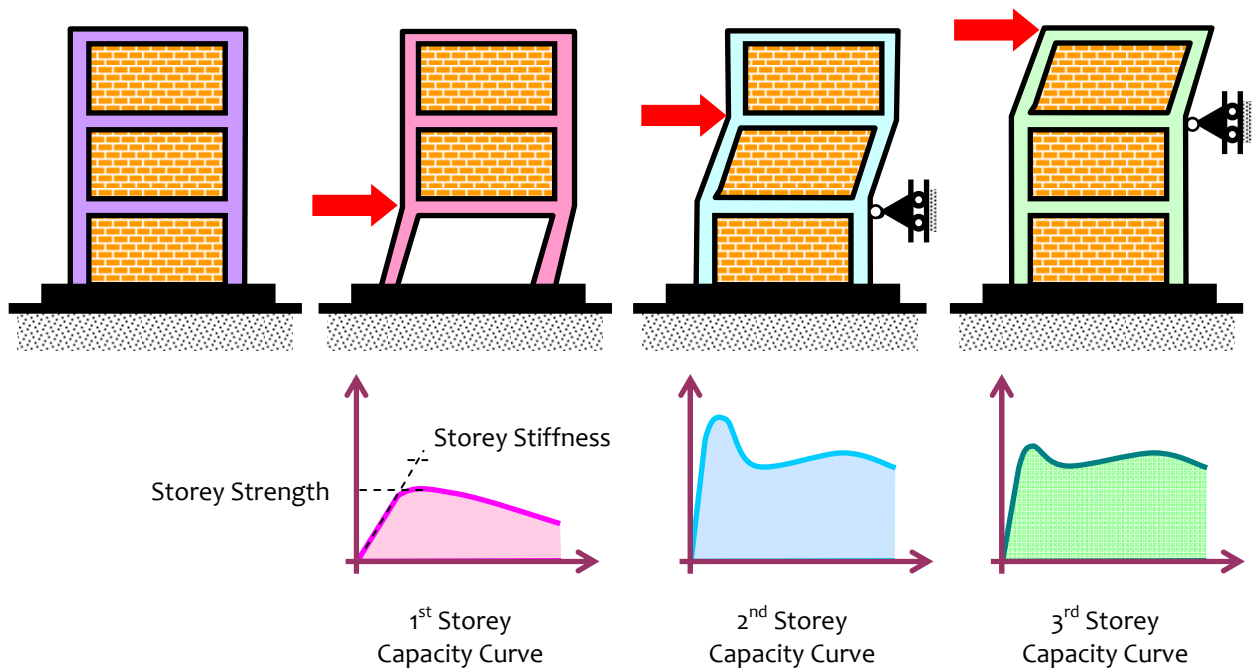


Figure 4.23: Method of estimating Storey Lateral Stiffness and Strength : Individual storey of building to be subjected to storey pushover analysis

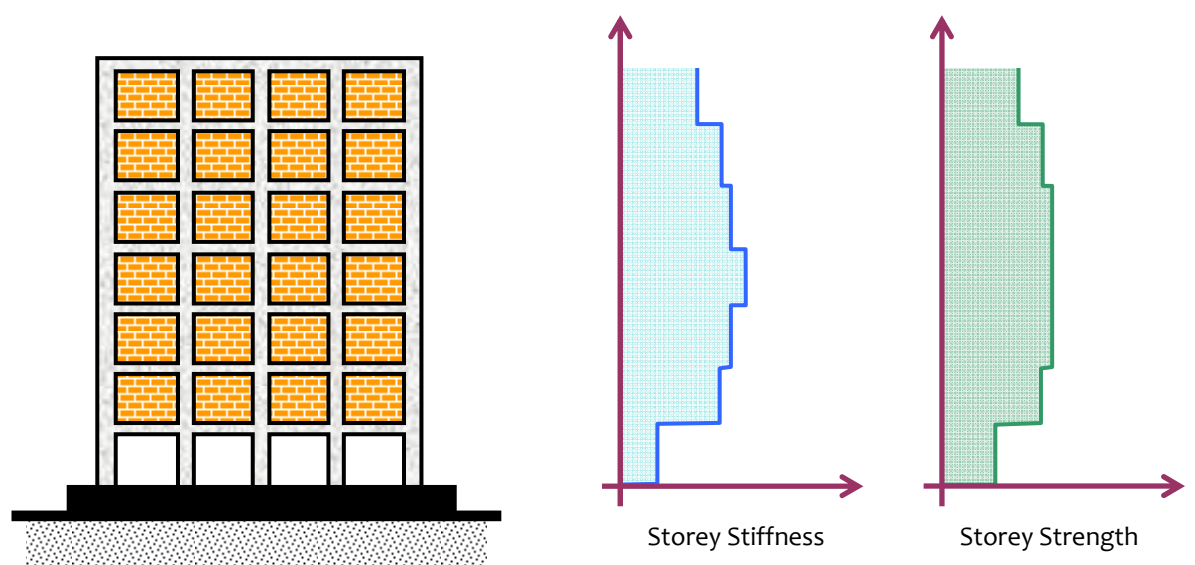


Figure 4.24: Variation of Lateral Stiffness and Strength of an OGS building: Large drop in both stiffness and strength at the open storey

(a) Open/ Flexible/ Weak Storeys in a Building

Open ground storey RC frame buildings are common in India; they are the dominant set of urban buildings today. But, poor performances of such buildings worldwide were known from almost a century ago. But, there must be compelling reasons (*e.g.*, *aesthetics* and *functionality*) other than *safety* that continues to push the construction of such buildings even today (Figure 4.25). When glass is used as infill material in the ground storey for aesthetics in place of brick masonry infills, the building becomes weak in that storey. This happens commonly in buildings housing shopping areas and restaurants in their ground storey. Also, when all unreinforced masonry (URM) infills are removed in the ground storey, the building is significantly weakened in the ground storey, but is strong in the upper storeys owing to large contribution to lateral stiffness by the URM infills. In other occasions of multi-storey buildings, the practice of reducing columns sizes at an intermediate storey results in sudden change in both stiffness and strength of the building.



Figure 4.25: *Weak storey in a building:* collapse of open storey in the five-storey residential building during 2001 Bhuj earthquake (India) in Bhuj town

Four buildings are considered for comparison, namely:

- (1) The benchmark 5-storey building *with URM infills in all storeys* (Figure 4.26a);
- (2) Bare-frame benchmark 5-storey building *with no URM infills in any storey* (Figure 4.26b);
- (3) Similar 5-storey building *with URM infills only in upper four storeys* (Figure 4.26c); and
- (4) Similar 5-storey building *with URM infills absent in third storey* (Figure 4.26d).

Pushover analysis is performed of these buildings. Infills are modeled as diagonal braces. The lateral strengths of the two buildings is different; the overall lateral strength of the building with open ground storey is smaller than that of the benchmark building (Figure 4.27). Also, the lateral deformed shape of the building shows that the upper portion of the building with infills in the upper storeys alone deforms like a stiff block in those four storeys (Figure 4.28).

Some efforts were made by some researchers to show that an open storey (which is both weak and flexible) at the top of the building can be used as a way of creating a tuned mass damper in the building. But, dynamic inelastic analysis of such buildings will suggest that the sudden collapse of the heavy top storey on the slab of the previous storey may result in progressive collapse of the building. Hence, such structural configurations should be avoided.

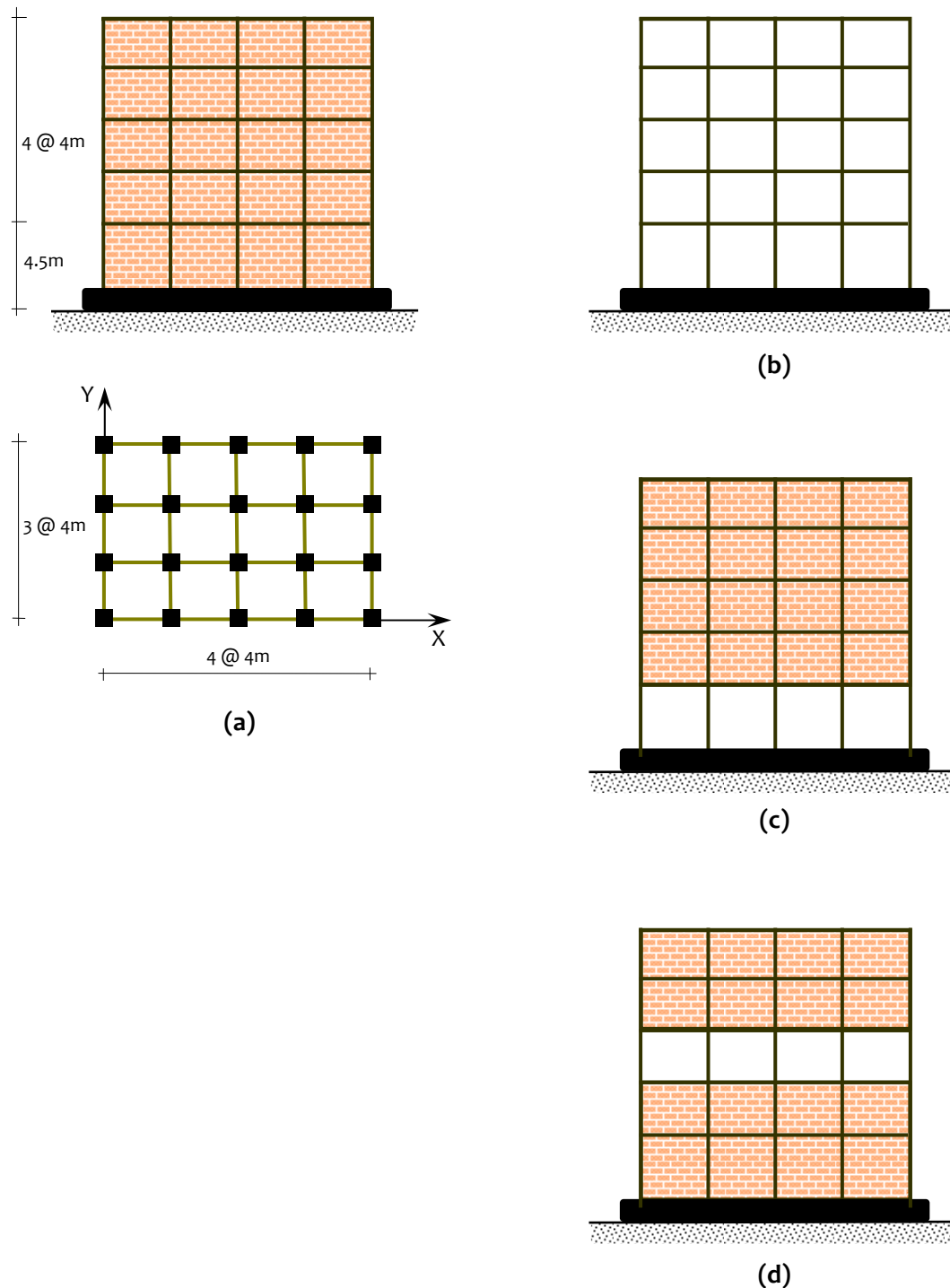


Figure 4.26: Open storey in a building: (a) Benchmark 5-storey building with URM infills in all storeys; (b) Bare-frame benchmark 5-storey building with no URM infills in any storey, (c) Similar 5-storey building with URM infills only in upper four storeys, and (d) Similar 5-storey building with URM infills absent in third storey

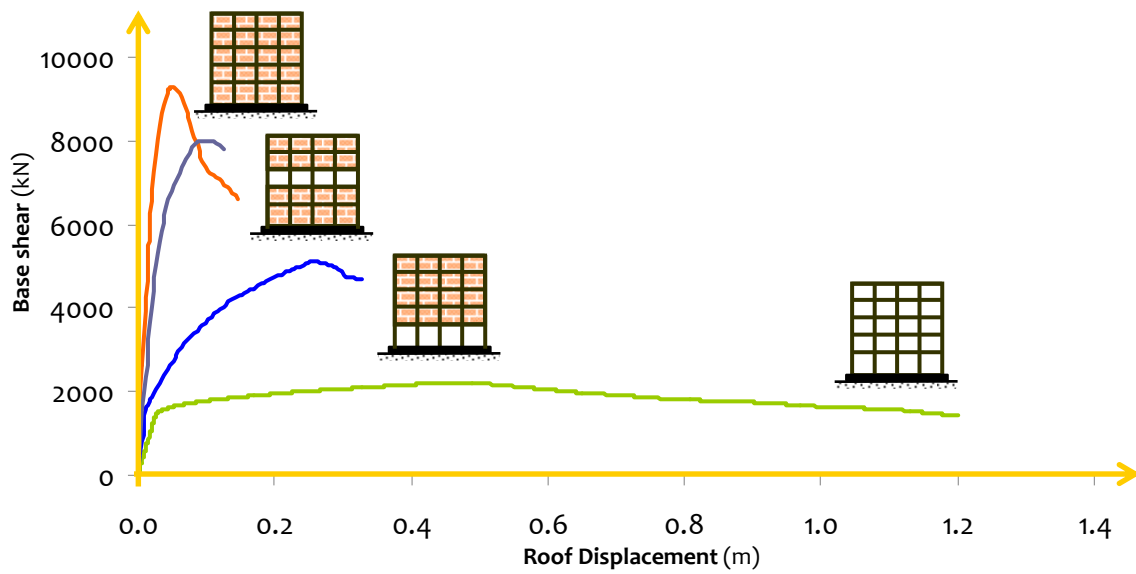


Figure 4.27: *Open storey in a building:* Building with infills only the upper four storeys has lesser overall strength and ductility

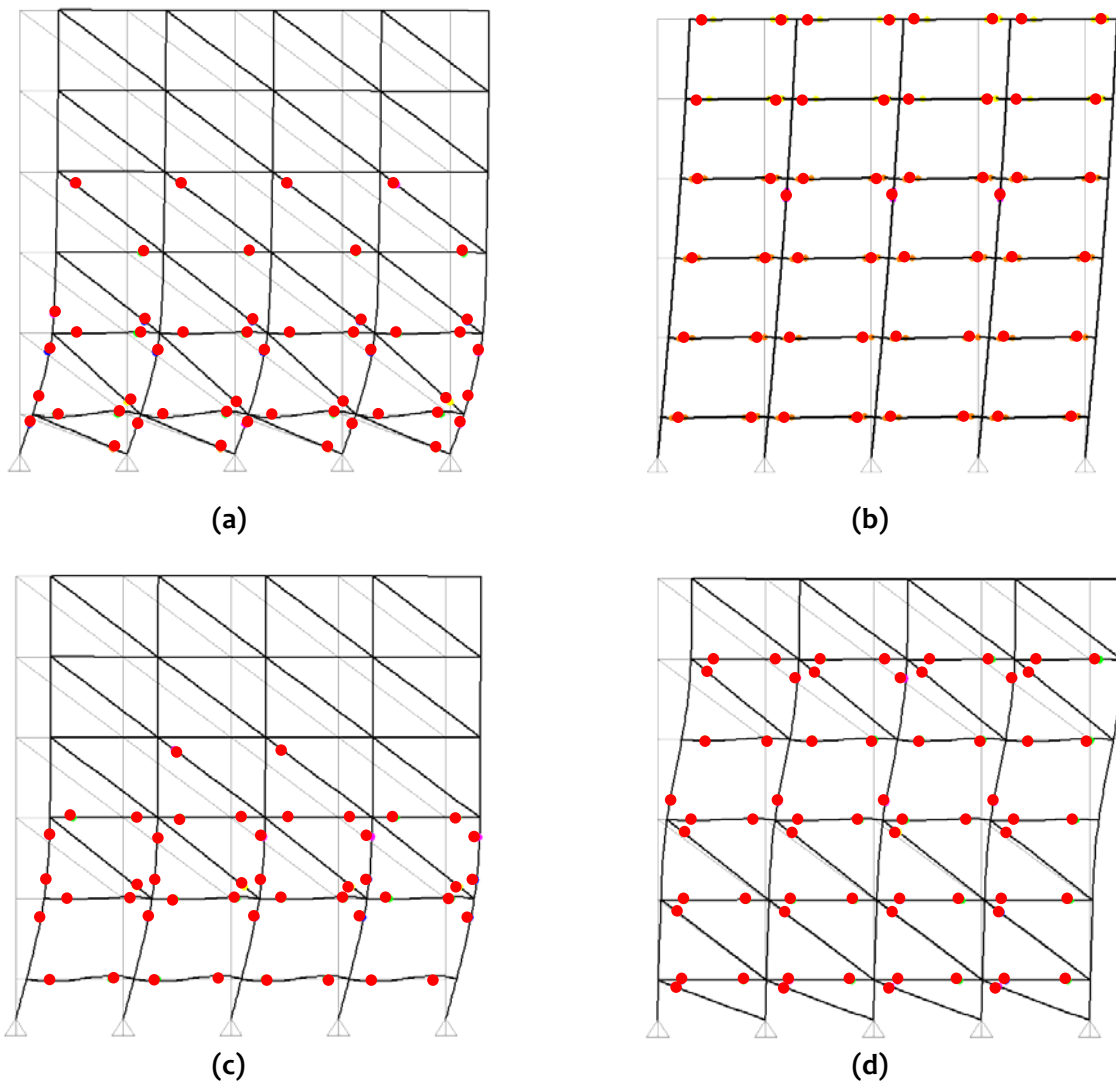
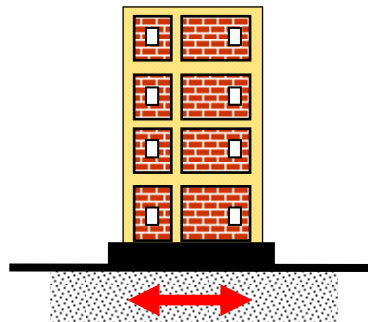
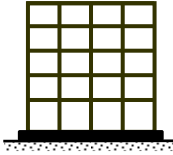
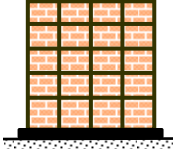
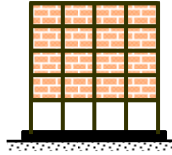
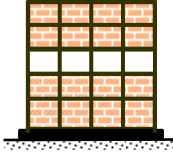


Figure 4.28: *Open storey in a building:* Deformation is uniform when the building has no sudden discontinuity (as in (a) and (b)), but all lateral deformation in building concentrated in open (flexible and weak) storey in building without infills (as in (c) and (d))

Animation Set 403

Pushover Analysis of Buildings Effect of Strength Discontinuity in Elevation



Bare Frame	Infilled Frame	Open Ground Storey	Weak Storey
 <p><u>Inelasticity distributed in beams</u></p>	 <p><u>No inelasticity in columns</u></p>	 <p><u>Inelasticity in columns in open ground storey</u></p>	 <p><u>Inelasticity in beams of open storey</u></p>
<p>Click on the 4 items above to see the sequence of hinge formation Best when viewed using Windows Media Player</p>			

(b) Discontinuous Structural Walls in a Building

The action is similar to that of the open ground storey in RC frame buildings. But, this discontinuity of the structural wall is more serious than the cases discussed in Section 3.2.3 (b), because the stiffness of the wall is orders of magnitude larger than that of the RC frame with URM infills. There is little to choose between the discontinuity of structural walls in the lower storeys and that in the upper storeys, but the former is the worst (Figure 4.29). Calculation of the stiffness and strength of the building will clearly identify the irregularity at the design stage itself in the storey with the structural wall discontinued. Unlike some other irregularity, there is no way out but to avoid this type of irregularity. The ideal option is to run the structural walls through the full height of the building. This irregularity is not permitted by most codes, and should not be adopted under *any* compelling circumstances. Some seismic design codes require the stiffness of any storey to be not less than a fraction of that in the storey above; for example, IS:1893 (Part 1) - 2007 suggests that the strength of any storey should not be less than 80 percent of that in the storey above.

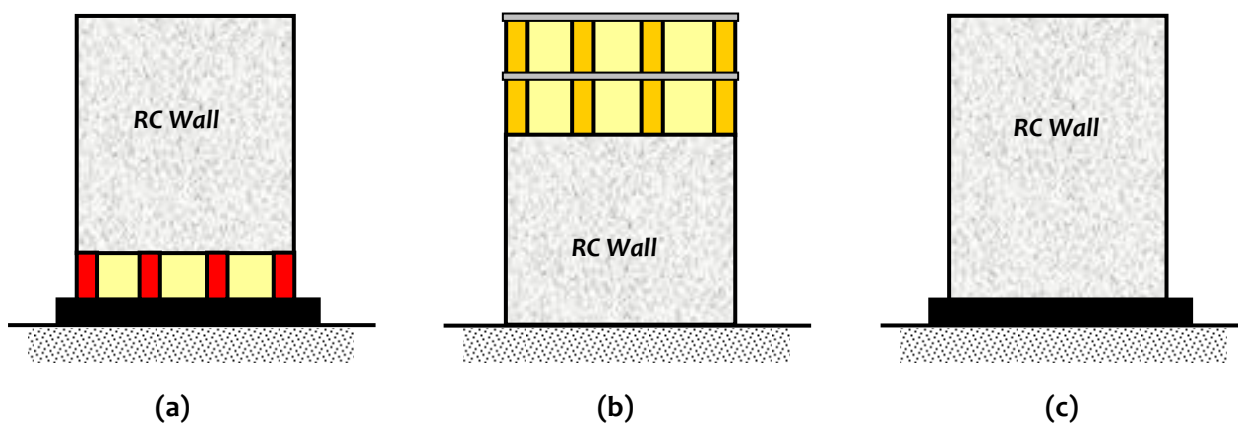


Figure 4.29: *Discontinuing Structural Walls in a building:* (a) Structural wall discontinued in ground storey, the worst choice, (b) Structural wall discontinued in upper storeys, also an unacceptable choice, and (c) Structural wall not discontinued, the best and *only* option

Three buildings are considered for comparison, namely:

- (1) The benchmark 5-storey building *with Structural Walls in all storeys* (Figure 4.30a);
- (2) Similar 5-storey building *with Structural Walls discontinued in the ground storey* (Figure 4.30b); and
- (3) Similar 5-storey building *with Structural Walls discontinued in the third storey* (Figure 4.30c).

Pushover analysis is performed of these buildings. The lateral strengths of the two buildings is different; the overall lateral strength of the buildings with wall discontinued (in the first/third storey) is far less than that of the benchmark building (Figure 4.31). Also, the lateral deformed shape of the building shows that the open storey of the building attracts all the deformation, irrespective of its location (Figure 4.32).

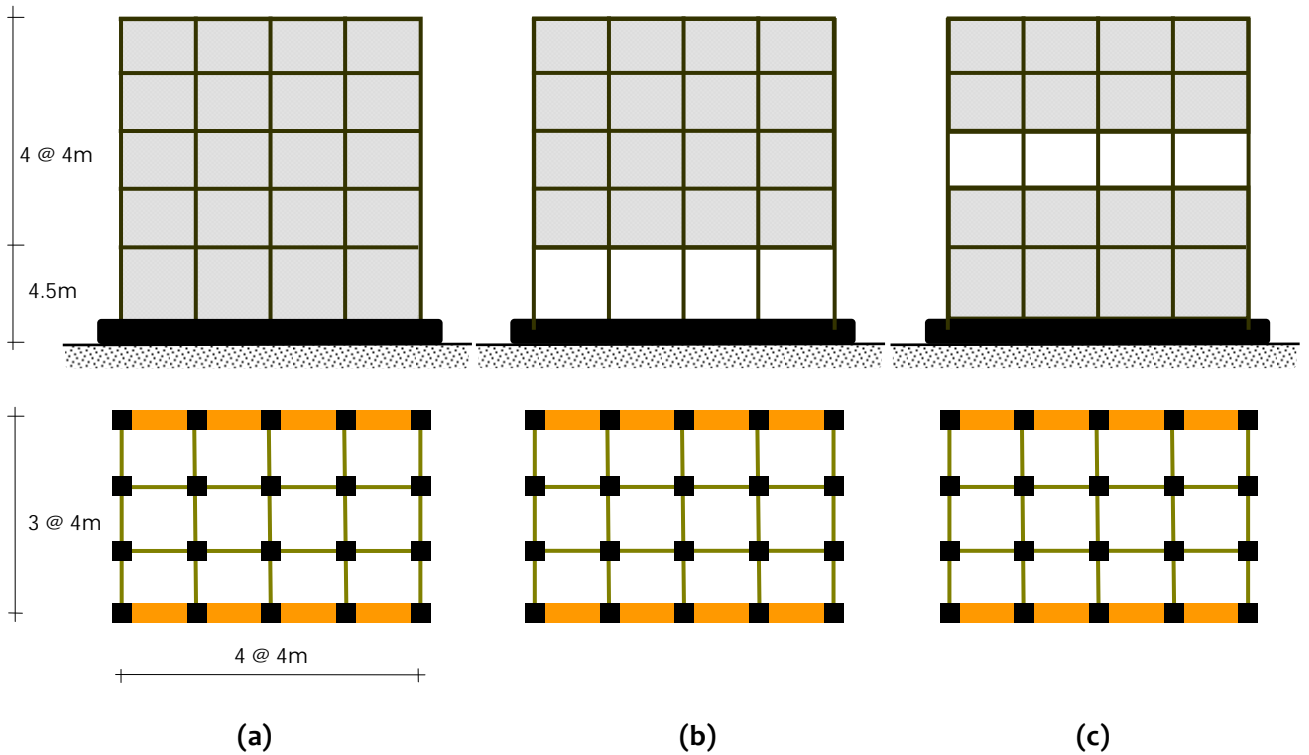


Figure 4.30: *Discontinuing Structural Walls in a building: (a) benchmark 5-storey building with Structural Walls in all storeys, (b) similar 5-storey building with Structural Walls discontinued in ground storey; and (c) similar 5-storey building with Structural Walls discontinued in third storey*

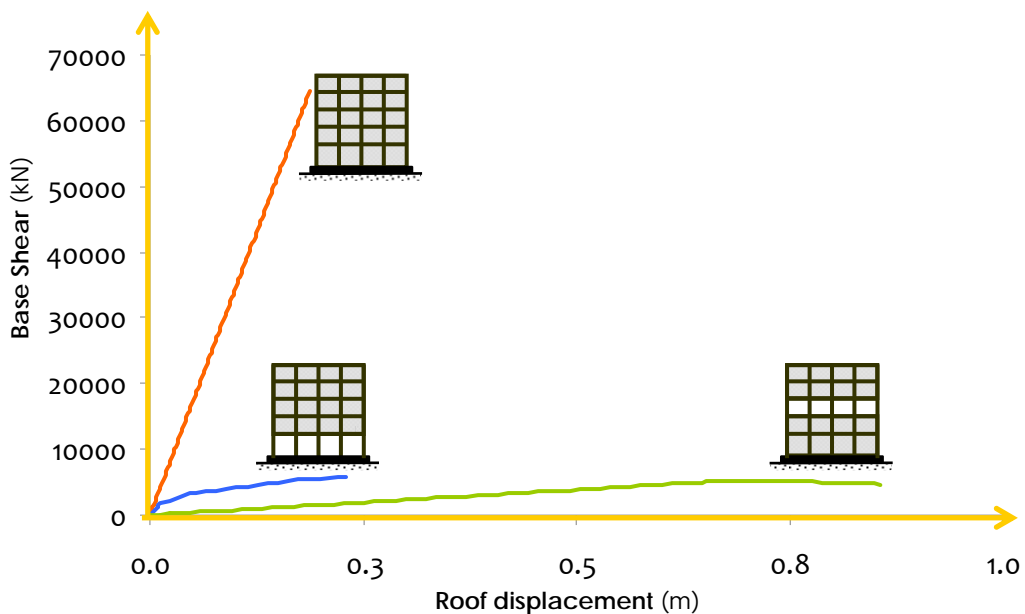


Figure 4.31: *Discontinuing Structural Walls in a building: It creates a weak link in the building's lateral load resisting system, and severely incapacitates the building from resisting the lateral shaking in spite of the presence of Structural Walls in the other storeys*

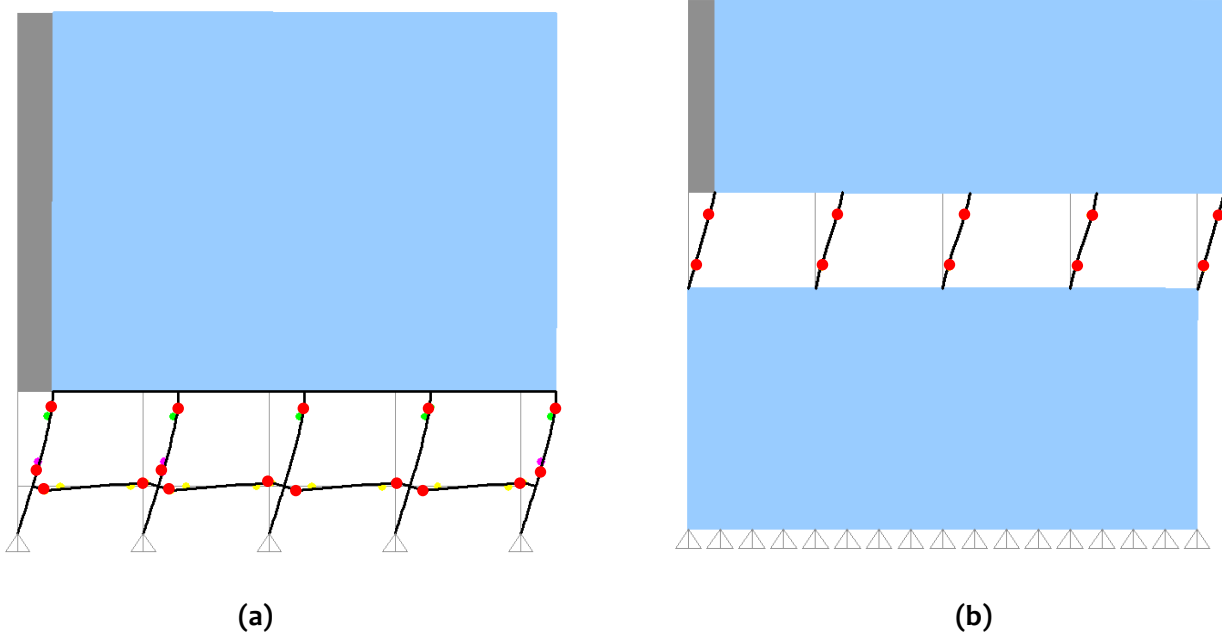
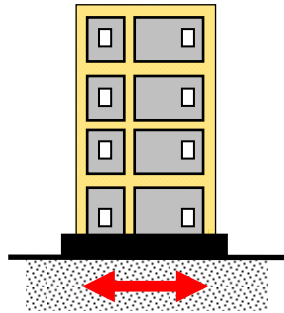
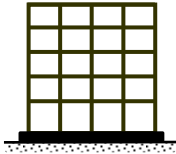
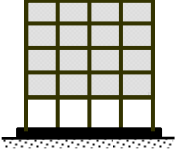
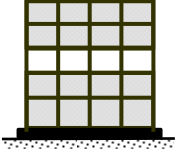


Figure 4.32: *Discontinuing Structural Walls in a building:* Open storey attracts the lateral deformation and hence large ductility demand in columns present at that storey, irrespective of the location of the open storey along the height

Animation Set 404

Pushover Analysis of Buildings Effect of Strength Discontinuity in Elevation



<i>Bare Frame</i>	<i>Open Ground Storey</i>	<i>Weak Storey</i>
 <i>Inelasticity distributed in beams</i>	 <i>Inelasticity in columns in open ground storey</i>	 <i>Inelasticity in columns in open storey</i>
<p>Click on the 3 items above to see the sequence of hinge formation Best when viewed using Windows Media Player</p>		

(c) Short Column Effect

Short column effect arises when a column in a RC frame building is restricted from moving owing to any obstruction. The obstruction can be:

- (1) Presence of unreinforced masonry infills of partial height of adjoining RC column (Figure 4.33);
- (2) Conditions arising from sloping ground, when some basement columns are shorter than others,
- (3) Presence of a mezzanine slab (which meets the columns at an intermediate height between the usual beam-slab system of the floors in RC buildings);
- (4) Presence of a staircase beam/slab or K-braces on building columns (which meets the columns at an intermediate height between the usual beam-slab system of the floors in RC buildings) (Figure 4.34); and
- (5) Presence of a plinth beam making the height of the column below it to be shorter than that of the column above.

Effective height of column over which it can bend is restricted by adjoining items mentioned above. Since lateral stiffness of a columns is inversely proportional to the cube of its height, this short-column effect is more severe when heights over which the columns are prevented from moving is large (or the unrestricted height of columns is small).

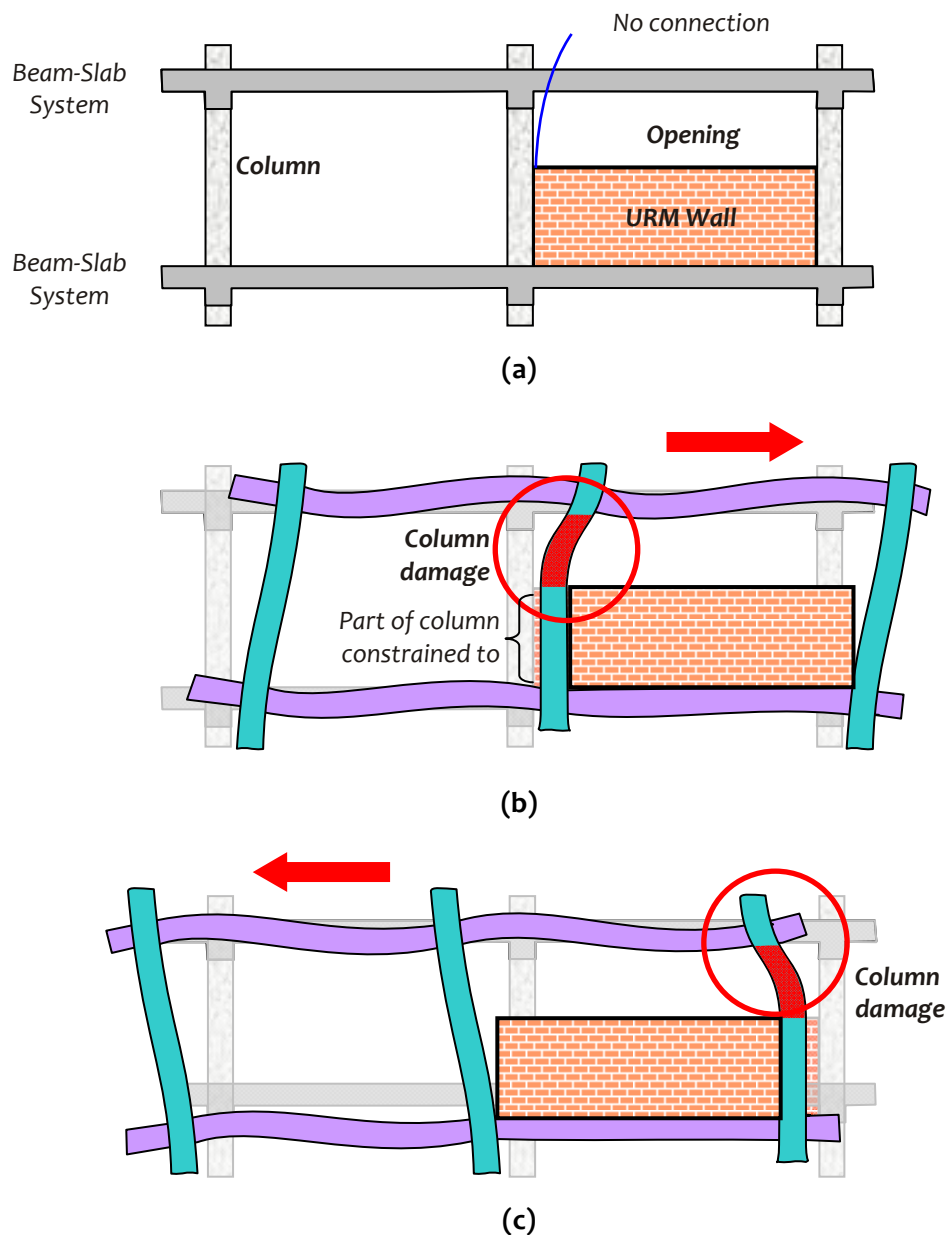


Figure 4.33: Short column effect owing to masonry infills adjoining the RC columns in buildings: Effective height of column over which it can bend is restricted by adjacent walls; this short-column effect is more severe when opening heights are small

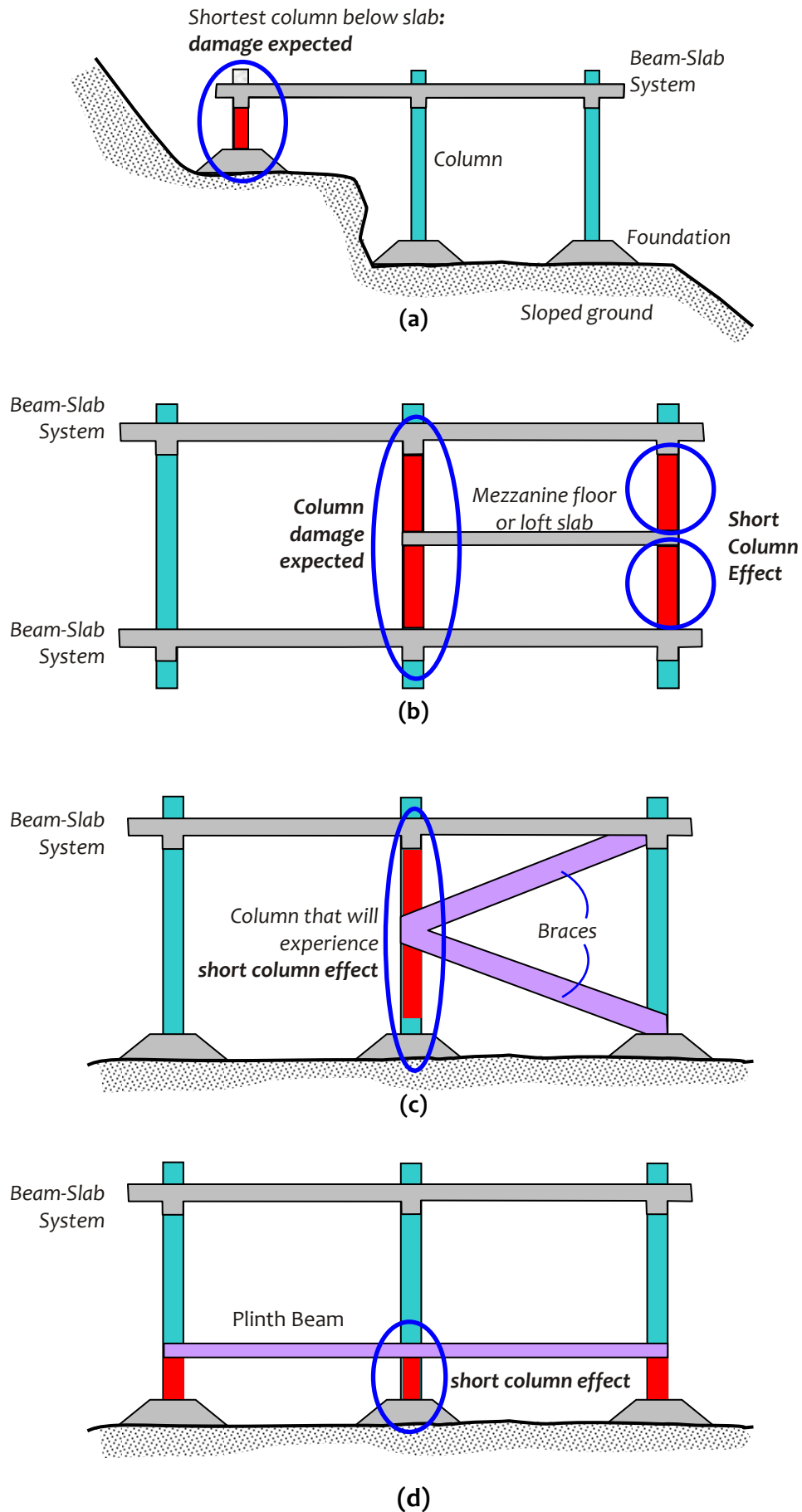


Figure 4.34: Short column effect owing to other causes in RC columns in buildings: Damages in restricted areas in columns (a) sloping ground, (b) mezzanine slab, (c) staircase beam/slab or K-braces on building columns, and (d) use of plinth beams in ground storey

Three buildings are considered for comparison, namely:

- (1) The benchmark 5-storey building *with not short column effect* (Figure 4.35a);
- (2) Similar 5-storey building *with sloping ground* (Figure 4.35b); and
- (3) Similar 5-storey building *with sloping ground but the sloped portion filled with an RC wall in the inclined portion only* (Figure 4.35c).

The deformation demand on the short columns is amplified as expected (Figure 4.36) under lateral loading on the building. Also, the lateral strength of the buildings is reduced (though only marginally), but the overall deformability is reduced (Figure 4.37). With the shear wall placed in the inclined portion of the foundation of the building, the short column effect is eliminated, but the fixity of the columns over the strong walls results in some restraint to the building.

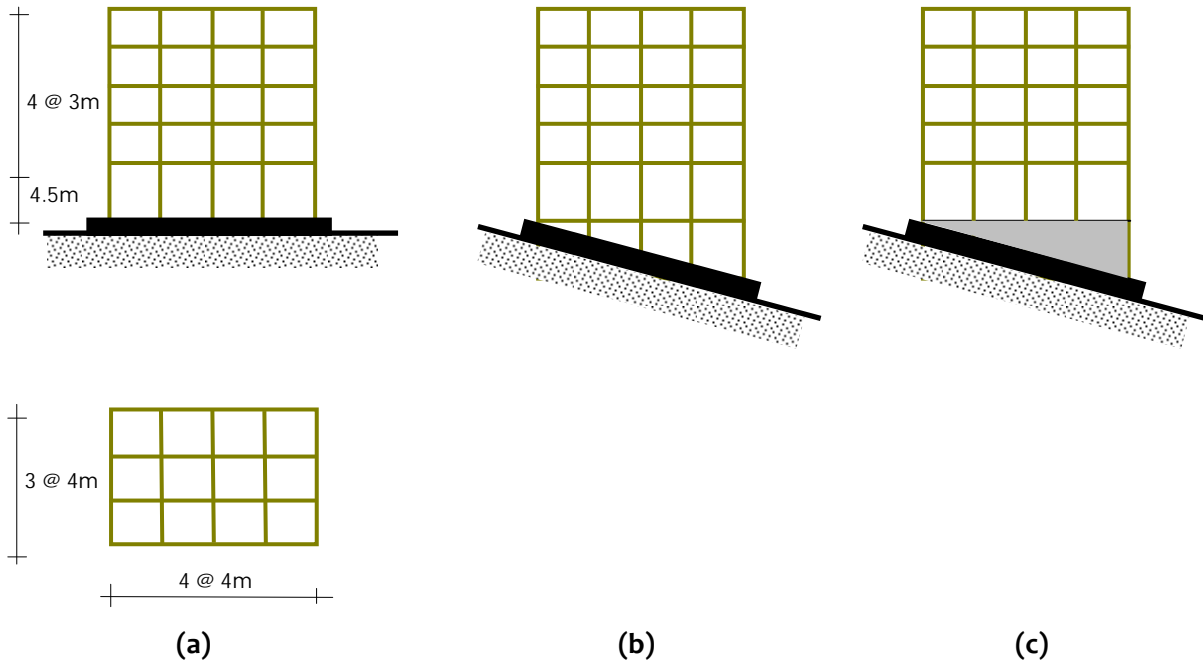


Figure 4.35: Short columns effect in a building: (a) Benchmark 5-storey building *with no short columns*, (b) Similar 5-storey building *with sloping ground*; and (c) Similar 5-storey building *with sloping ground but the sloped portion filled with an RC wall in the inclined portion only*

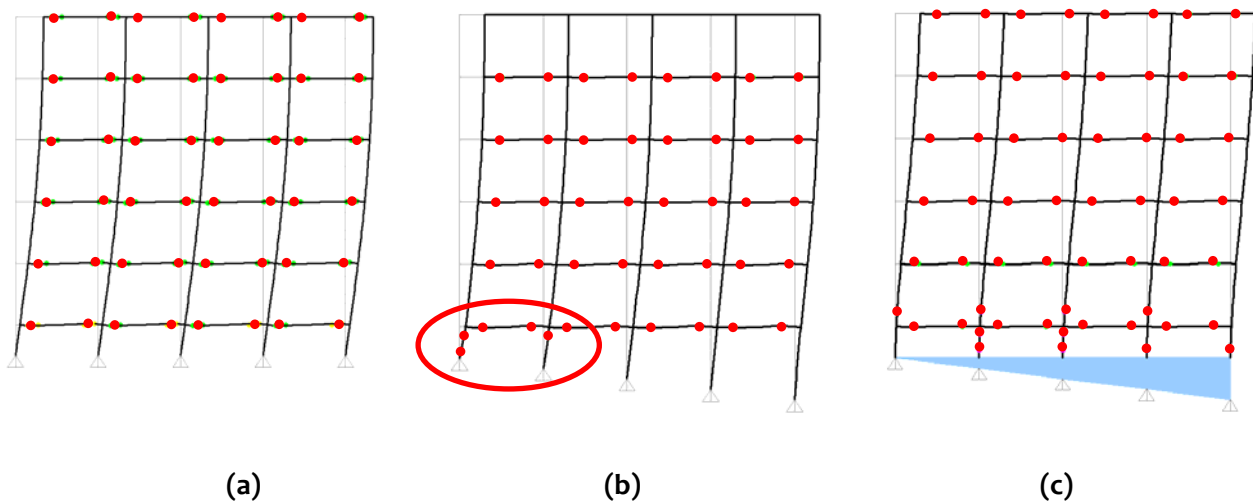


Figure 4.36: Short columns effect in a building: Columns of shorter height attract more lateral shear

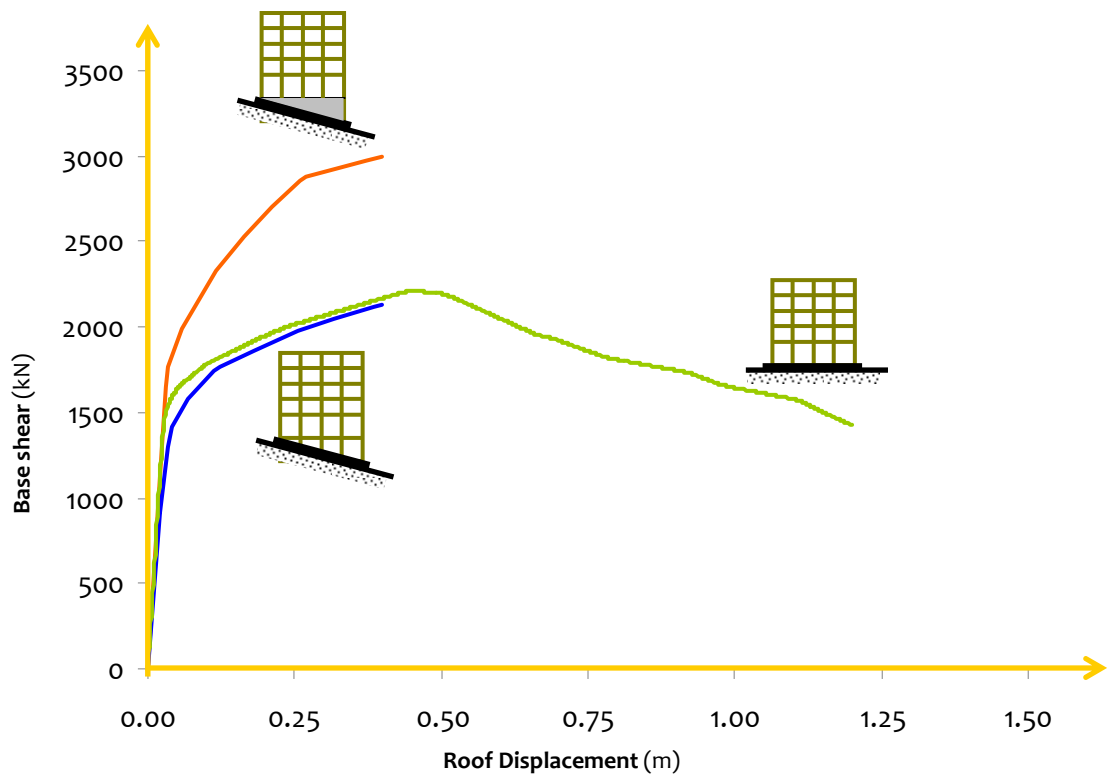
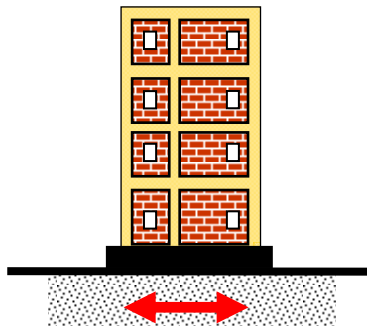
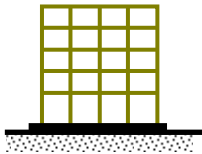
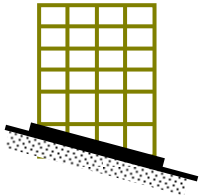
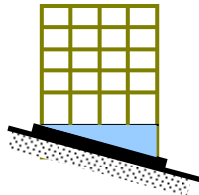


Figure 4.37: *Short columns effect in a building:* Columns of shorter height attract more lateral shear early in the displacement demand, and reduce deformation capacity of the building

Pushover Analysis of Buildings
Effect of Stiffness Irregularity



<p><i>Benchmark Building</i></p> 	<p><i>Frame on Sloping Ground</i></p> 	<p><i>Frame with Wall on Sloping Ground</i></p> 
<p><i>Inelasticity distributed in beams</i></p>	<p><i>Inelasticity in columns in open ground storey</i></p>	<p><i>Inelasticity in columns in open storey</i></p>
<p>Click on the 3 items above to see the sequence of hinge formation Best when viewed using Windows Media Player</p>		

4.3 DUCTILITY

Ductility of a building is its capacity to accommodate large lateral deformations along the height. It is quantified as the ratio μ of *maximum deformation* Δ_{\max} that can be sustained just prior to collapse (or failure, or significant loss of strength) to the *yield deformation* Δ_y . Thus, a ductile building exhibits large inelastic deformation capacity without significant loss of strength capacity (Figure 4.38). The state of the building prior to collapse or at failure is called the *plastic* condition of the building. Through seismic design, buildings are designed and detailed to develop favourable failure mechanisms that possess *specified lateral strength, reasonable stiffness* and, above all, *good post-yield deformability*.

4.3.1 Definitions of Ductility

(a) Contributors to Ductility in Reinforced Concrete Buildings

This property of a building, namely *ductility*, makes it possible to design it for only a fraction of the forces that are induced in the building, if it were to remain elastic all through, because the loading imposed by earthquake shaking is *displacement-controlled*. In a ductile building, the structural members and the materials used therein can stably withstand inelastic actions without collapse and undue loss of strength at deformation levels well beyond the elastic limit. Ductility helps in dissipating input earthquake energy through hysteretic behavior (Figure 4.39).

Earthquake-resistant design of buildings relies heavily on ductility for accommodating the imposed displacement loading on the structure. Overall ductility of a building is realized through ductility at different levels, namely structural or *global, member, section* and *material* levels. Good material ductility helps in achieving better section ductility, which, in turn, helps in achieving improved member ductility. And, global ductility depends on all three of them - member, section and material ductility.

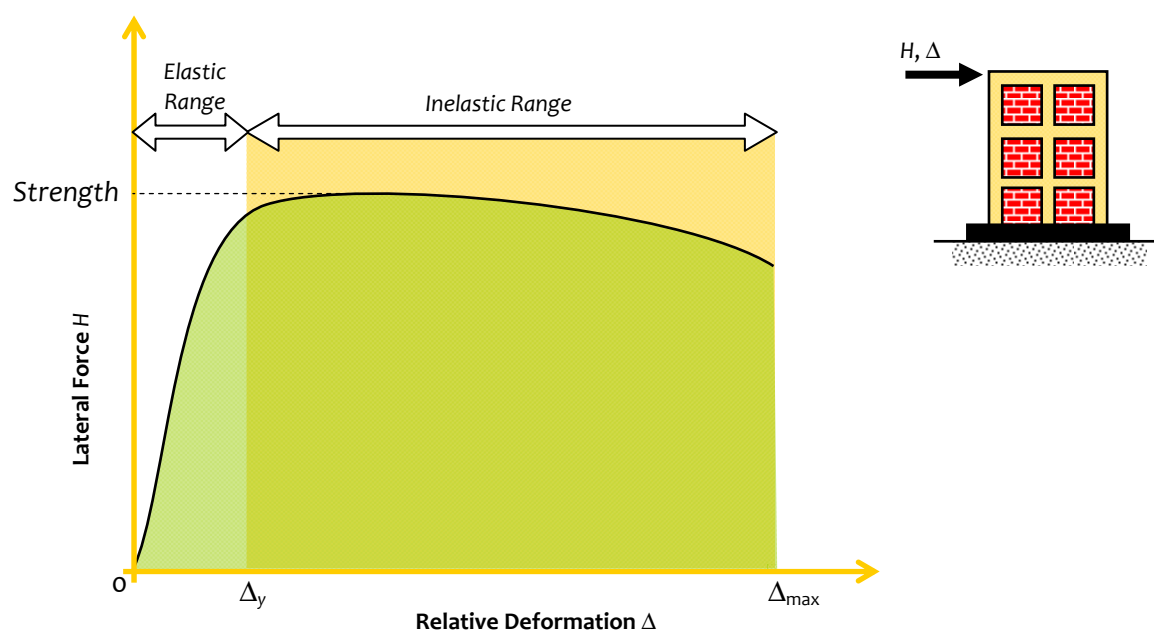


Figure 4.38: Ductility: Good *inelastic* range of deformation after the initial *elastic* deformation

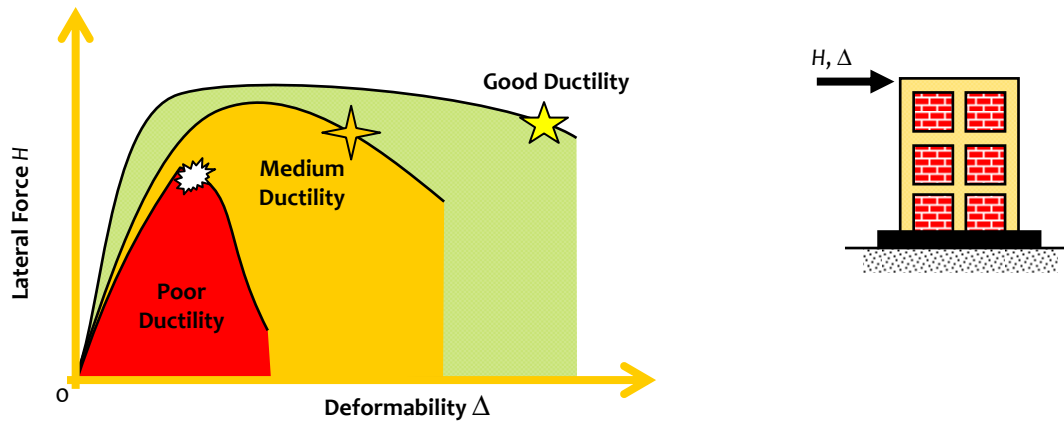


Figure 4.39: Energy absorption owing to ductility: Three structures possess different levels of ductility, and hence different energy absorption capacities

Making individual members of the frame ductile is the key effort in earthquake resistant design and construction. Making a RC member ductile is challenging, because most of the volume of the material in reinforced concrete is concrete, which is extremely brittle in comparison to reinforcing steel (Figure 4.40). The concrete inside the lateral ties is confined by the closed loop lateral ties with 135° hook ends; this prevents the failure of concrete during cyclic earthquake loading. Concrete grades of cube strengths 20-40 MPa are usually referred to as normal concretes and those with strengths greater than 60 MPa as high strength concretes. In either case, the ultimate compressive strain of concrete is an important property (depends on its strength) that determines the overall ductility of the member. In general, the ultimate compressive strain reduces with increase in strength. All this is true for unconfined concrete. In RC members, transverse reinforcements designed and provided primarily for resisting shear force, play an important role in *confining* the concrete, apart from holding the longitudinal reinforcement bars in position and preventing their buckling in compression. The concrete within the transverse and longitudinal steel is held against the bars and is prevented from dilating in the transverse direction thereby enhancing its peak strength and ultimate strain capacities (Figure 4.40a).

Locally, the confining action is more near the transverse steel and lesser farther away. The use of closer spacing of transverse bars or ties makes confining pressure more uniform and effective. When a concrete cylinder is crushed without any ties in it to confine the concrete, concrete sustains a moderate compression stress, and the stress level reduces as the concrete begins to crush and reaches zero when the concrete is completely crushed. Conversely, if the concrete is confined with circular or square steel ties, not only can the concrete withstand higher compressive stress, but also be compressed further without a sudden drop-off of load. This is a relatively ductile behaviour. Thus, concrete (an originally-brittle material) seemingly gains ductility when provided with confining transverse steel. This material ductility is essential towards making of a ductile member.

Steel by nature is far more ductile than even confined concrete (Figure 4.40b). Further, mild steel with its lower carbon content and simple manufacturing process is more ductile than high-strength steel. Mild steel can stretch much more than high-strength steel before breaking, but understandably more mild steel reinforcement is needed to achieve the same bending strength as a high-strength reinforced member. The use of high-strength steel as transverse ties helps in increasing the confining action on the concrete, also, in preventing shear failure. But, it must be ensured that such steels have at least the prescribed minimum elongation specified in the seismic design codes; for instance, IS:13920 requires that steels used in earthquake-resistant constructions should have at least 14.5% elongation at fracture.

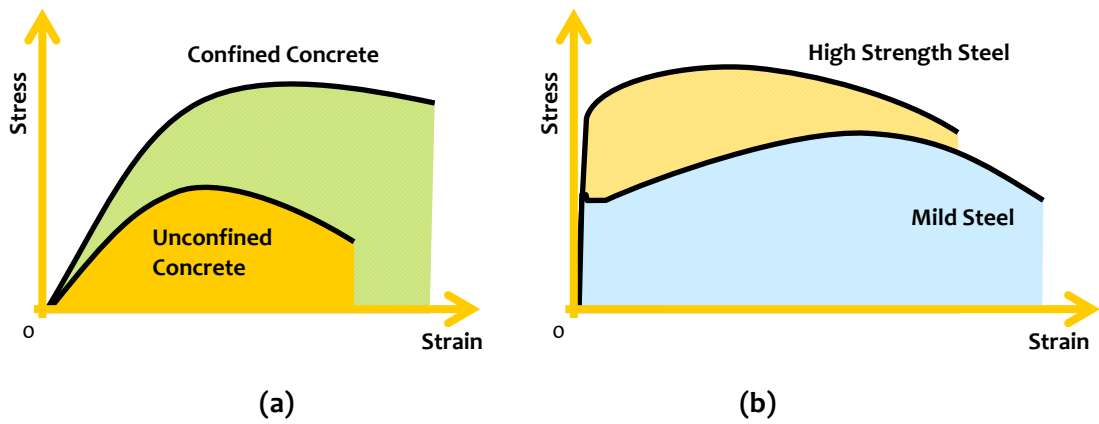


Figure 4.40: *Material ductility:* Stress strain curves of structural materials in reinforced concrete member - (a) concrete (unconfined and confined) and (b) reinforcing steel

Material ductility is directly reflected in section ductility through the cross-section property of the member, namely *moment-curvature relationship*. With under-reinforced flexural behaviour of the section, good section ductility can be achieved through use of proper choice of quantity and distribution of steel, grade of concrete, and geometry of cross-section. This is part of the process of design. Good member ductility (member-end *moment versus rotation relationship*) is then a direct consequence of good section ductility (*moment versus curvature relationship*) and is reflected in structure ductility (*say, total seismic force versus roof displacement*). There is no direct quantitative relationship between structure ductility and member ductility. But, in general, increasing member ductility increases structure ductility. Section ductility increases (Figure 4.41) as flexural yielding increases, concrete grade increases, steel grade decreases, tension reinforcement decreases, compression reinforcement increases, and axial force in the member decreases. Thus, beams are more ductile than columns.

RC frame members fail owing to a number of deficiencies. These failures manifest as shear failure (diagonal tension and diagonal compression), bond slip failure, flexural over-reinforced failure, flexural under-reinforced failure, and torsional failure. Of these, the preferred failure mode is the flexural under-reinforced failure (Figure 4.42). When this happens, the RC member stretches in flexure on the tension side (without any failure in the concrete on the compression side) and exploits the ductility of the steel bars. This condition of the RC member is called the *plastic hinge*; typically, this plastic action spreads over a small length of the member, called *plastic hinge length*.

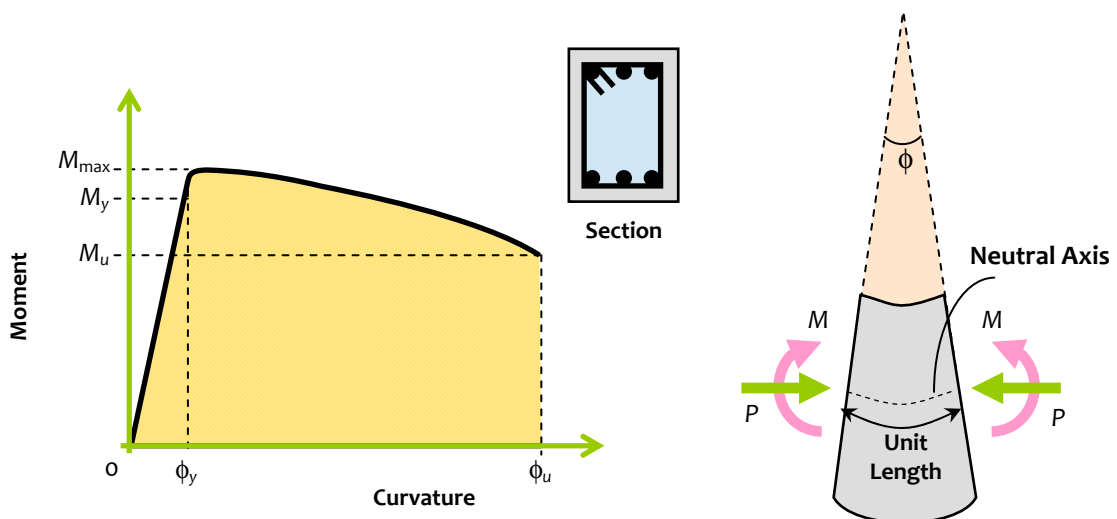


Figure 4.41: *Section Ductility:* Typical $M-\phi$ relationship of an RC member under flexure and axial load

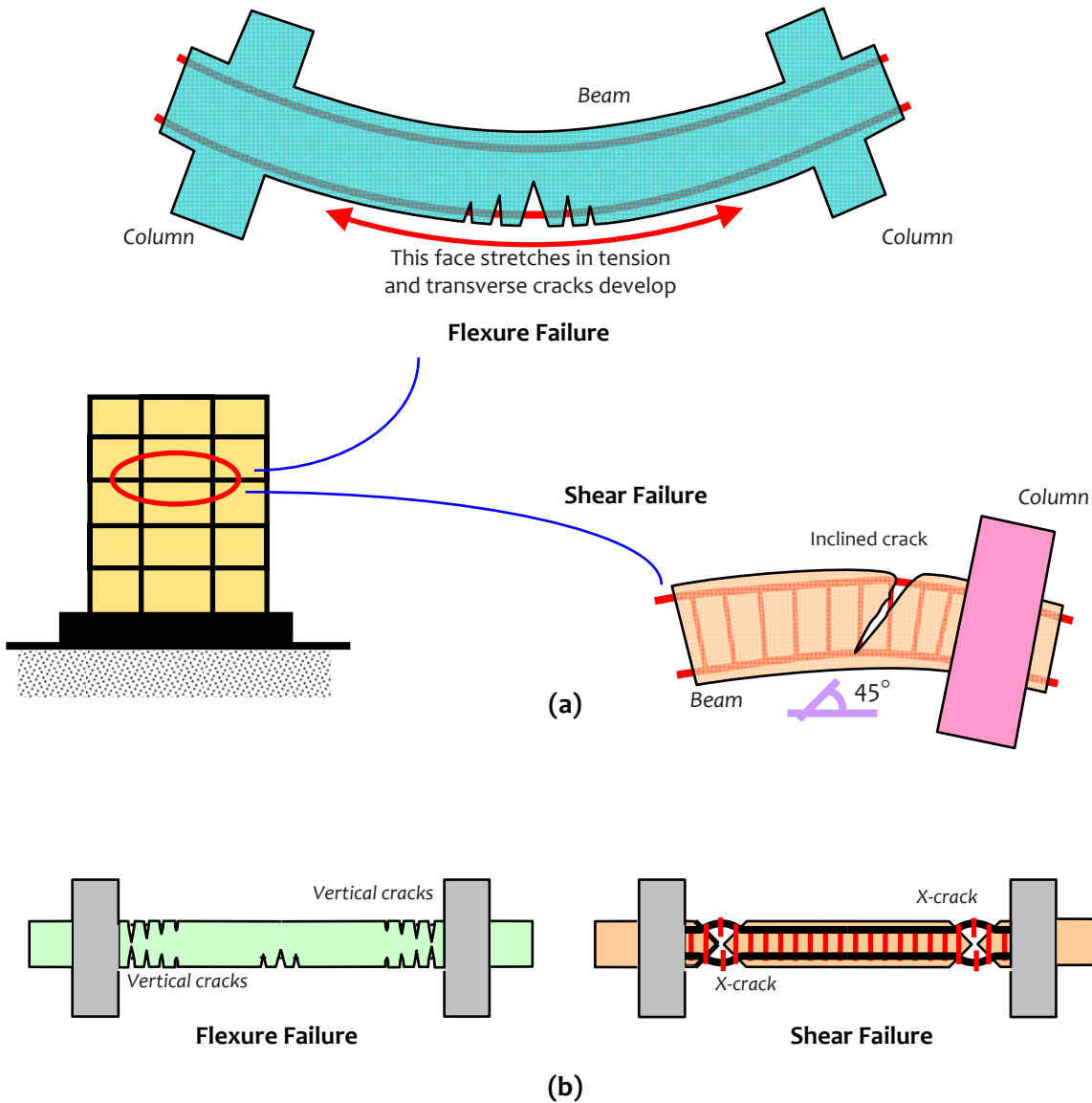


Figure 4.42: Basic modes of failure: the desirable flexural mode: (a) monotonic actions, (b) cyclic actions

Seismic design codes recommend the use of closely spaced transverse reinforcement at all locations where plastic hinges are likely to be formed. This increases confinement of concrete that is one of the main contributors to ductility. The first significant difference occurs in the constitutive stress-strain relation of concrete itself; the same is shown in Figure 4.43 for a 300×400 deep beam of M30 grade concrete with Fe 415 grade 3Y16 and 3Y20 top and bottom longitudinal reinforcement bars, respectively. The unconfined concrete case represents the beam with transverse reinforcement of Y8 @ 300c/c, while transverse reinforcement of Y8 @ 150c/c significantly increases strain capacity and ductility of the concrete (along with nominal increase in strength) (Figure 4.43).

Next, the effect of enhanced ultimate strain of concrete is reflected in the moment-curvature relation of the section (Figure 4.44); the section curvature ductility is significantly increased. But, the moment capacity of the section is not increased since the original section is under-reinforced wherein the maximum moment capacity is governed by tensile capacity of the steel and not the strength of the concrete. But, final failure of a RC section is governed by the maximum compressive strain concrete can withstand before it spalls. With confinement, the maximum strain capacity of concrete is increased, and consequently, curvature ductility of the section alone is enhanced.

The effect of enhanced concrete strain capacity and section curvature capacity is reflected in the global load-deformation response of structures. Pushover responses are shown in Figure 4.45 of benchmark building with and without special transverse confining reinforcement. The global drift capacity of the building is significantly increased (to more than 4%) with additional confining reinforcement compared to one without (with drift capacity of 1.5% only).

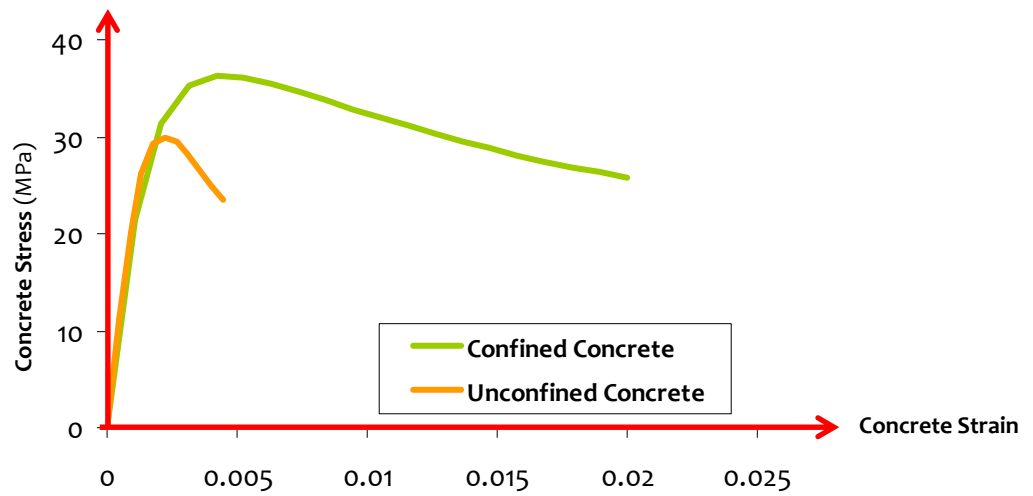


Figure 4.43: *Material ductility:* Effect of confinement on constitutive relation of concrete

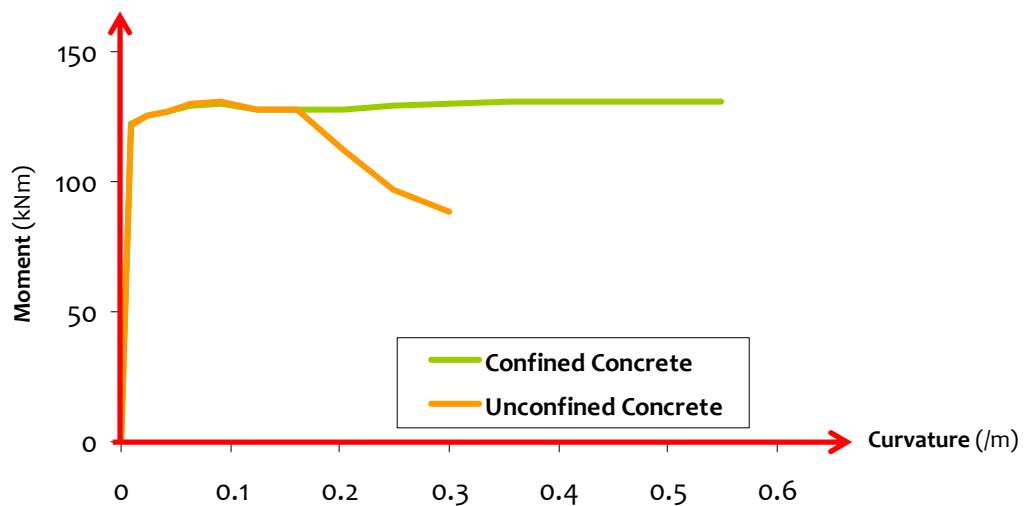


Figure 4.44: *Section ductility:* Effect of confinement on constitutive relation of concrete

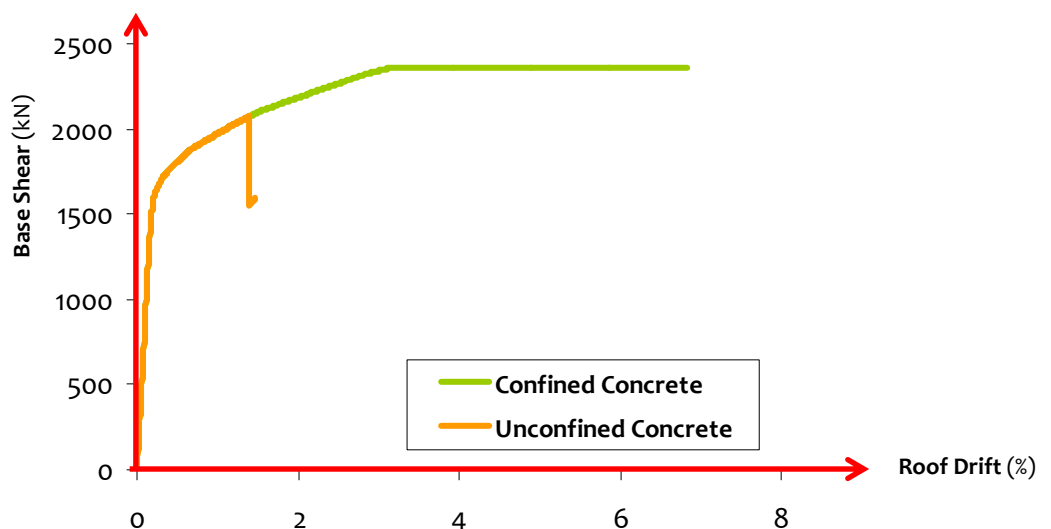


Figure 4.45: *Structure ductility:* Effect of confinement on constitutive relation of concrete

Consider a 400×400 square column of M30 grade concrete with Fe415 grade 4Y20 longitudinal steel and two different transverse reinforcements, namely Y8 @ 300c/c representing *unconfined* case, and Y8 @ 75c/c representing *confined* condition. The design and actual stress-strain relations of the materials (reinforcing steel and concrete) are shown in Figure 4.46. The *P-M* interaction graphs shown in Figure 4.47 are obtained considering (a) *design* stress-strain relations of materials, (b) *unconfined* concrete and *actual* steel stress-strain relations, and (c) *confined* concrete and *actual* steel stress-strain relations. The maximum overstrength compressive and flexural capacities are about two times the design strengths; but this occurs at an axial load level above the balanced point on the *P-M* interaction curve, which is generally below 0.3 to 0.4 times the pure compressive load capacity level of the member for normal rectangular sections.

Columns must not be designed to carry axial compression load above the balanced point as this leads to brittle compression failure. Figures 4.48-4.50 show the moment-curvature curves of the column section at different axial load levels for above three considered material stress-strain relations. There is no or little curvature ductility above the balanced point in all cases. But, curvature ductility is significantly enhanced by confinement below the balanced point and will prevent brittle collapse of columns in case of extreme earthquake shaking. Thus, (i) columns must always be designed to carry axial load less than the capacity at balanced point, and (ii) closely spaced transverse reinforcement providing confinement to concrete is critical to good column behaviour, although columns are required to remain elastic during expected levels of seismic actions.

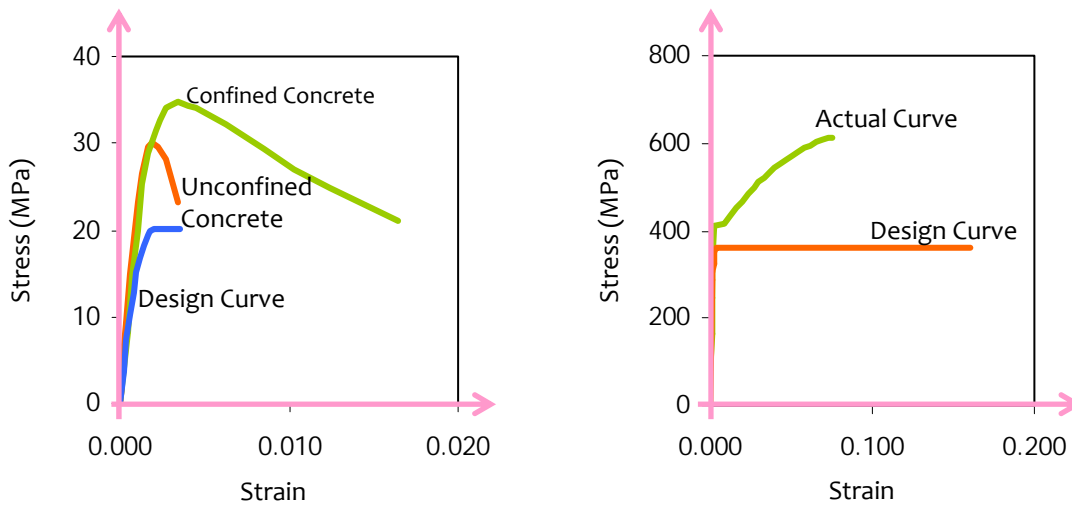


Figure 4.46: Material properties: Design and actual constitutive relations of concrete and steel

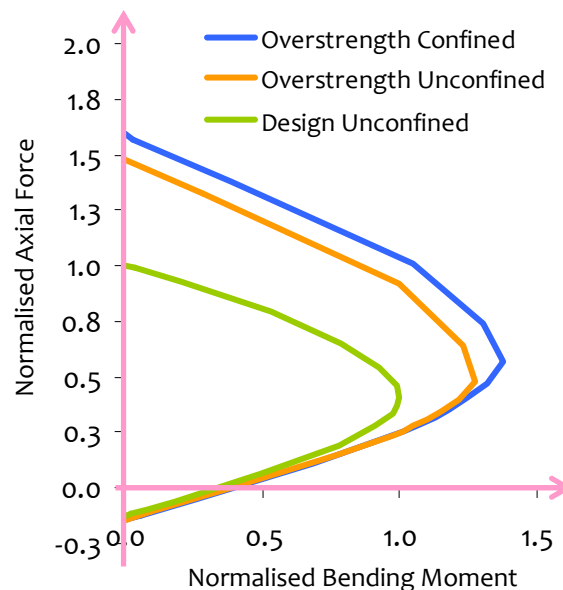


Figure 4.47: Section properties: *P-M* interaction envelopes using design and actual constitutive relations of concrete and steel

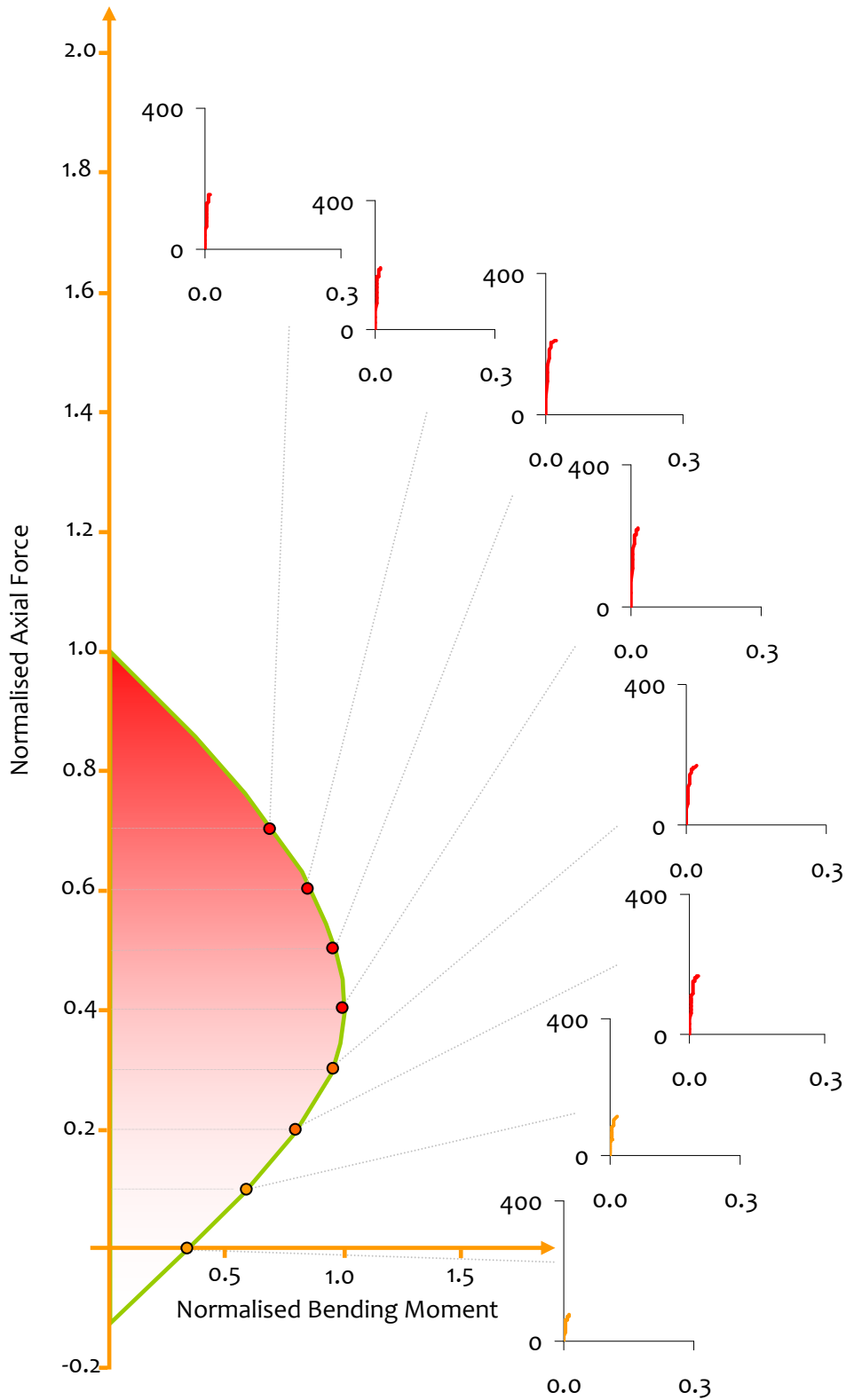


Figure 4.48: DESIGN P-M interaction envelopes: M- ϕ relations at different axial loads

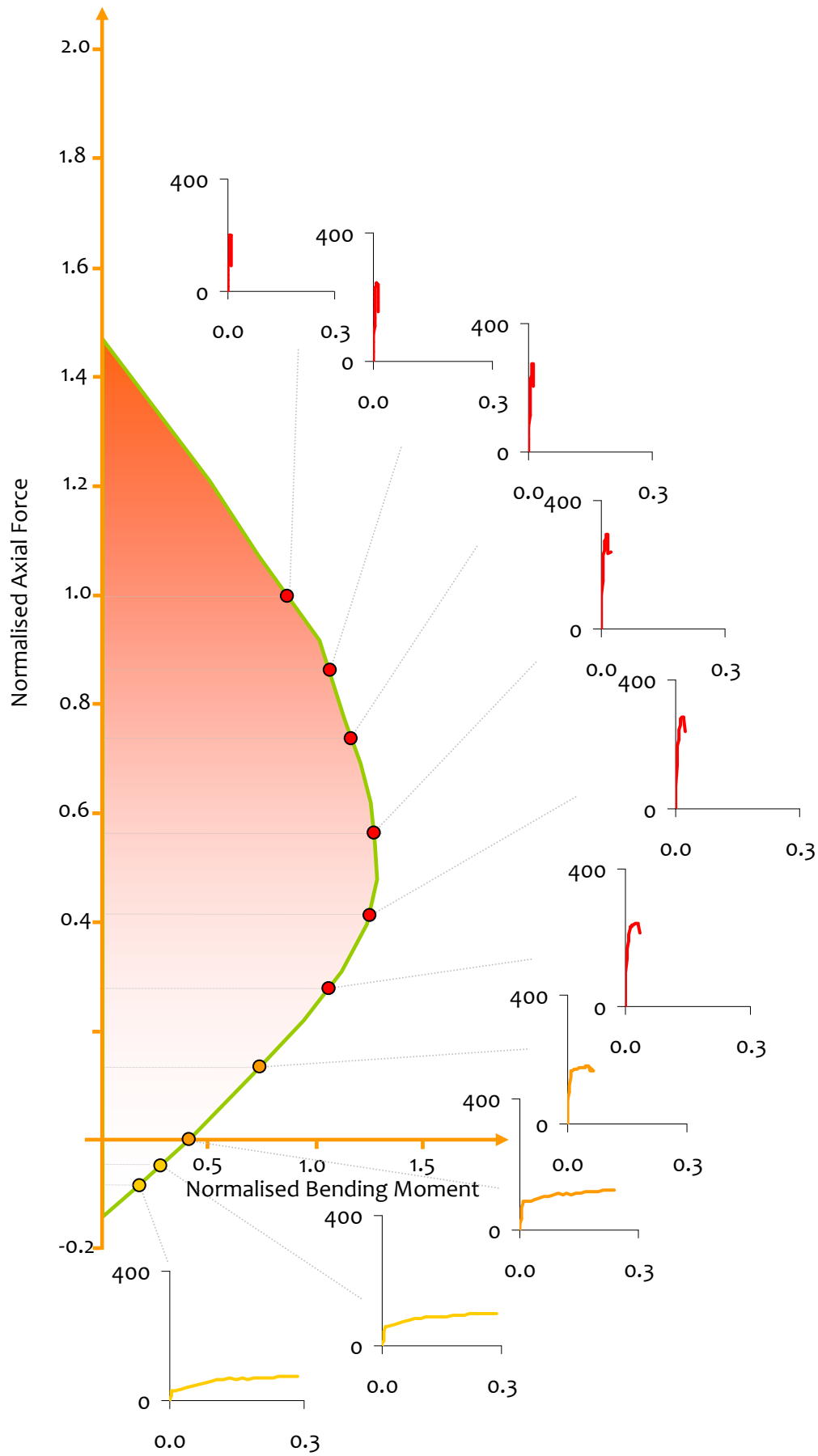


Figure 4.49: ACTUAL P - M interaction envelopes: with UNCONFINED concrete M - ϕ relations at different axial loads

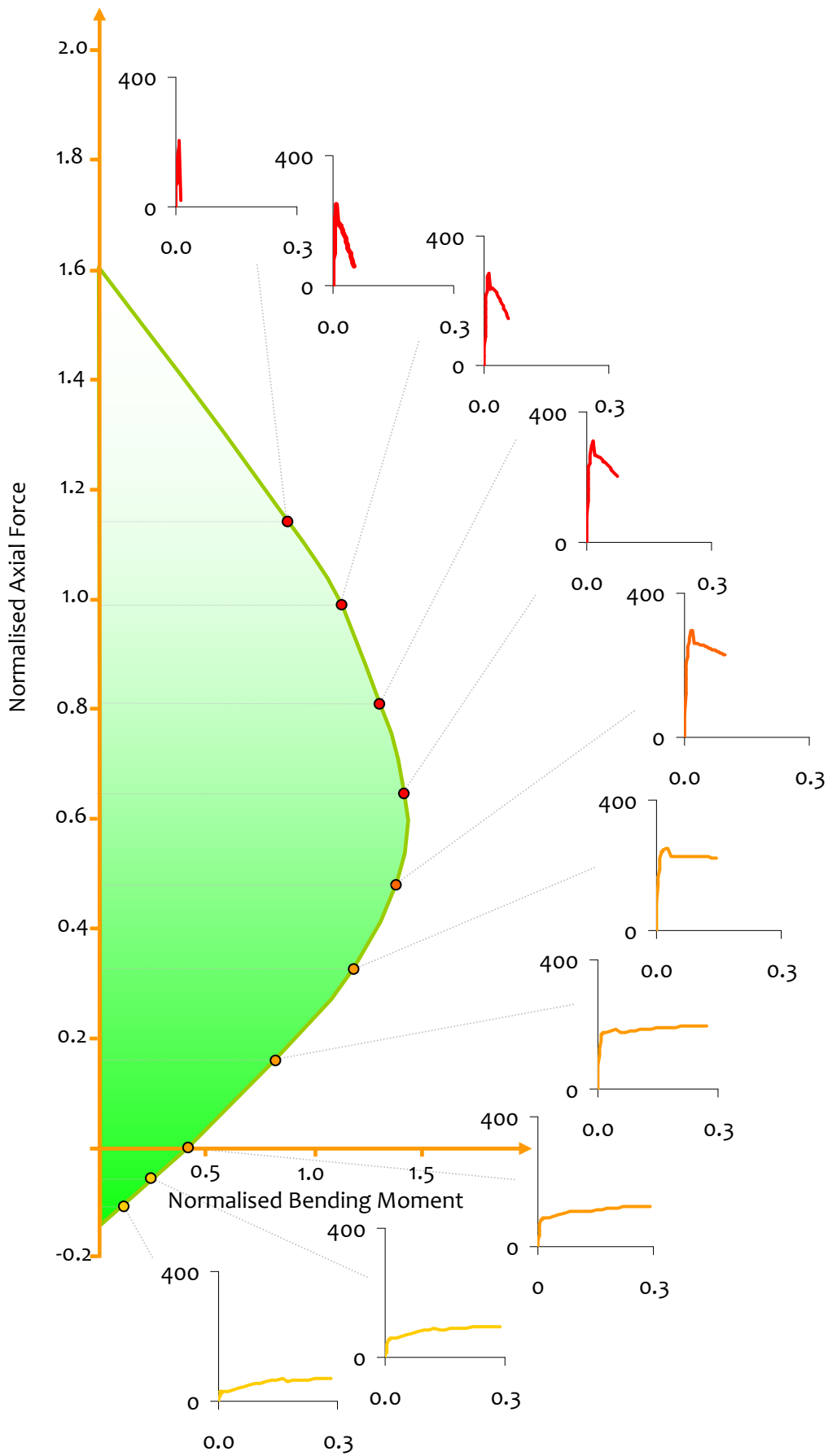
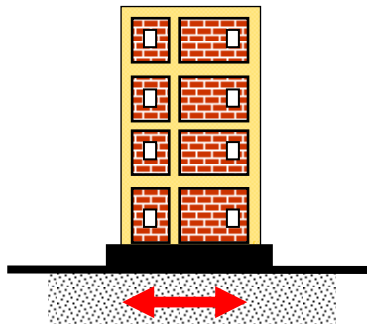
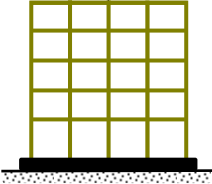
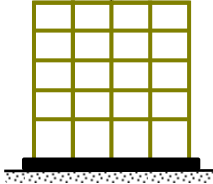


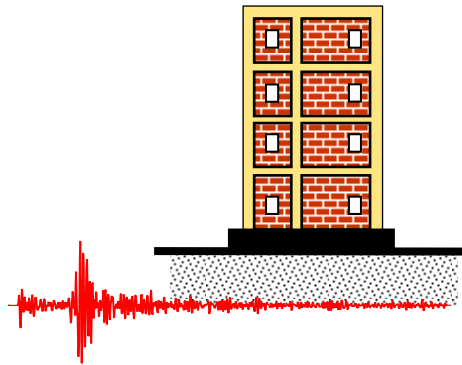
Figure 4.50: ACTUAL P - M interaction envelopes: with CONFINED concrete M - ϕ relations at different axial loads

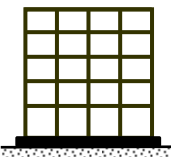
Pushover Analysis of Buildings
Effect of Concrete Confinement



<p><i>Building with structural members</i> CONFINED</p> 	<p><i>Building with structural members</i> UNCONFINED</p> 
<p><u>Confined Concrete</u></p>	<p><u>Unconfined Concrete</u></p>
<p>Click on the 2 items above to see the sequence of hinge formation Best when viewed using Windows Media Player</p>	

Time History Analysis of Buildings
Effect of Reversed Cyclic Loading



<p>Bare Frame</p> 		
<p><u>Deformed Shape</u></p>		
<p><u>Axial Force Diagram</u></p>	<p><u>Shear Force Diagram</u></p>	<p><u>Bending Moment Diagram</u></p>
<p><i>Click on the 4 items above to see the reversal of the above stress-resultants</i> Best when viewed using Windows Media Player</p>		

(b) Achieving Ductility in Reinforced Concrete Buildings

It is possible to design RC buildings to possess a required lateral strength and initial stiffness by appropriately proportioning the size and material of its members. But, achieving sufficient ductility through mobilization of plastic condition is an involved activity. For example, an overall *structural ductility* of only 2-5 may be possible in RC buildings (based on, roof displacement Δ), even when mild steel material of reinforcement bars have a *material ductility* (i.e., ratio of ultimate strain and yield strain) as large as 150-170. Post-earthquake investigations of buildings damaged during earthquakes and extensive laboratory tests on full-scale specimens identified preferable methods of design and detailing that lead to improved ductility.

Ductility in RC buildings can be enhanced by ensuring the following:

- (a) Choosing a regular seismic structural configuration for the building with adequate redundancy,
- (b) Tune the damage to occur at predetermined locations in members, and
- (c) Ensure that only a certain type of damage occurs (i.e., that with increased *member ductility*).

The Architect is responsible for achieving the first step and the Structural Engineer for the next two steps. The Structural Engineer must follow the requirements of the relevant design codes, and tune desired type of damage to occur only at prescribed locations spread over the RC building.

(c) Assessing Ductility available in Buildings

Design for *ductility* has not been internalized sufficiently by professional design engineers, in comparison with design for the other three virtues of earthquake-resistant construction. Direct quantitative design for ductility is still not common. It is usually done through *prescriptive* design, like discouraging some structural configurations, imposing material specifications, demanding only acceptable sequencing of possible failure modes, and recommending certain specific detailing schemes. Accounting all these at the first step, the actual ductility expected from the building or a member is then obtained through analysis, like the *Pushover Analysis*.

Consider a steel portal frame of a building (Figure 4.51) subjected to a horizontal displacement applied at the level of the beam. A *steel* portal frame is adopted here *intentionally*, because the concepts of yielding are easy to understand in steel than in reinforced concrete. The moment-rotation characteristics of beams and columns can be idealized as elasto-plastic $M-\theta$ curve. The yield rotation may be obtained using

$$\theta_y = \left(\frac{M_p}{EI} \right) l_p = \left(\frac{M_p}{EI} \right) d, \quad (4.1)$$

where $M_p = \sigma_y Z_p$, d is the depth of the section, Z_p and I the geometric section properties, and E the elastic modulus. Two cases of ultimate plastic rotation are considered here (Figure 4.52), namely $\theta_{u1} = 3\theta_y$ and $\theta_{u2} = 30\theta_y$. The associated $P-M$ interaction diagram of the section is necessary for this analysis, because as lateral deformation is imposed on the frame, the members may develop axial forces that will interact with bending moments generated in them (Figure 4.53).

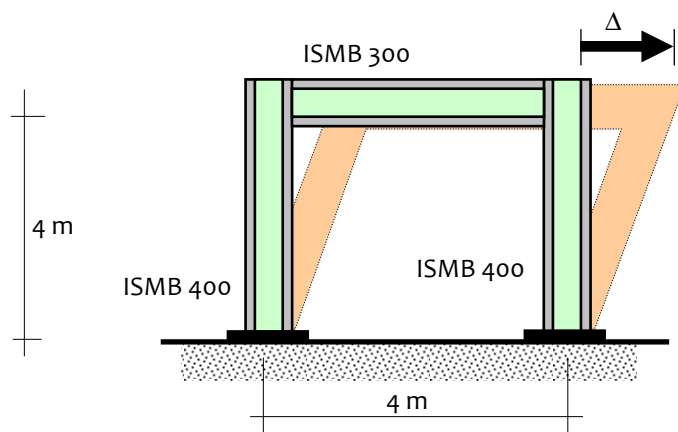


Figure 4.51: Portal frame considered to demonstrate ductility

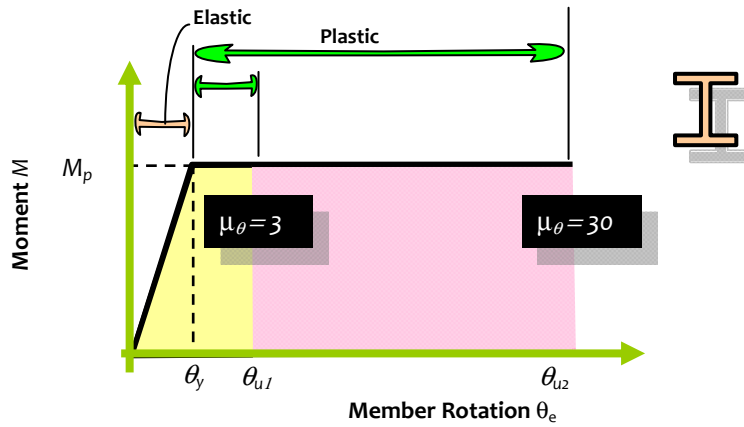


Figure 4.52: Moment-rotation characteristics of the beam and column members used

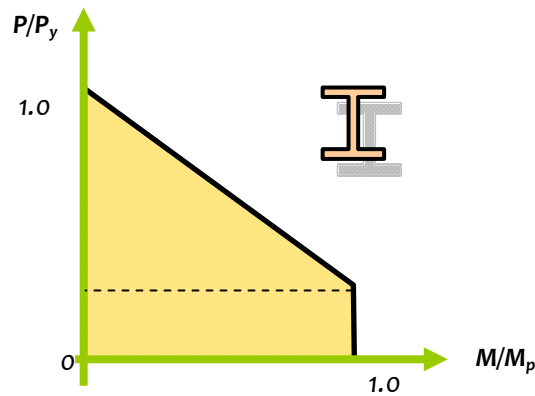


Figure 4.53: Idealised Axial Force - Bending Moment interaction diagram of beam and column members

Similarly, the axial force - axial displacement characteristics also of beams and columns can be idealized as elasto-plastic $P-u$ curve. Yield displacement in tension may be obtained using

$$u_y = \left(\frac{P_y}{EA} \right) L, \quad (4.2)$$

where $P_y = \sigma_y A$, and in compression using

$$u_{cr} = \left(\frac{P_{cr}}{EA} \right) L, \quad (4.3)$$

in which $P_{cr} = \sigma_{cr} A$, in which σ_{cr} is the critical buckling stress in compression; buckling is usually a concern in steel buildings, but not necessarily in RC buildings. A and L are the geometric properties, and E the elastic modulus. Again, two cases of ultimate plastic displacement are considered here (Figure 4.54), namely $u_{u1} = 3u_y$ and $u_{u2} = 30u_y$ in both the tension and compression regions.

And, again the shear force - shear displacement characteristics also of beams and columns can be idealized as elasto-plastic $V-v$ curve. The shear displacement may be obtained using

$$v_y = \left(\frac{V_y}{GA_s} \right) L, \quad (4.4)$$

where $V_y = \frac{\sigma_y}{\sqrt{3}} A_s$, in which σ_y is the yield stress. A_s and L are the geometric properties, and G the shear modulus. Again, two cases of ultimate plastic displacement are considered here (Figure 4.55), namely $v_{u1} = 3v_y$ and $v_{u2} = 30v_y$ both on the positive and negative shear directions.

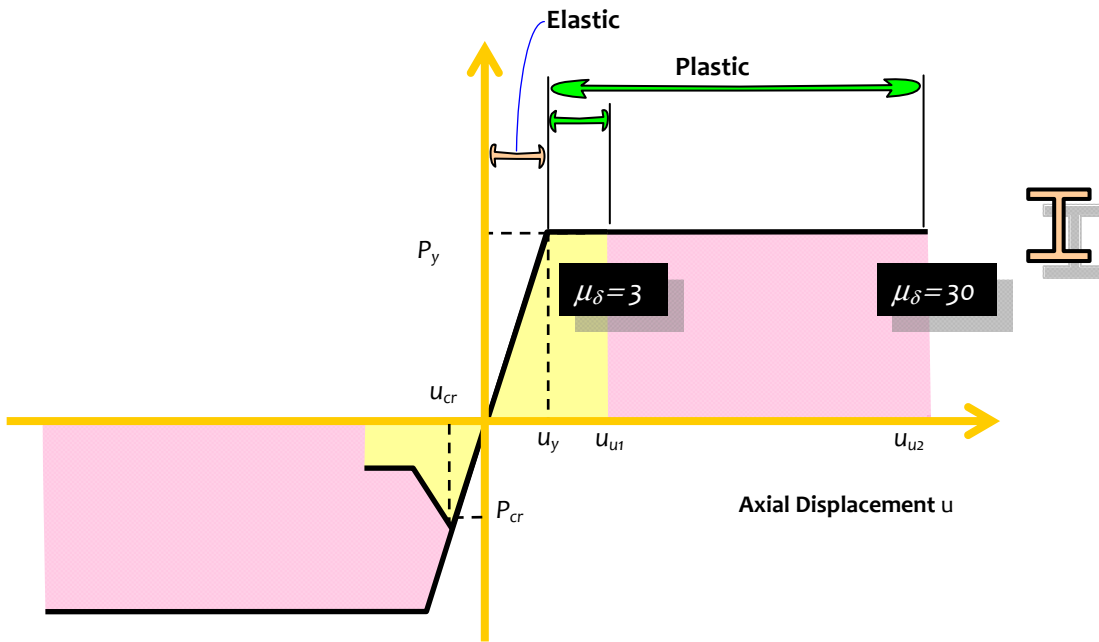


Figure 4.54: Axial force – axial displacement characteristics of the beam and column members used

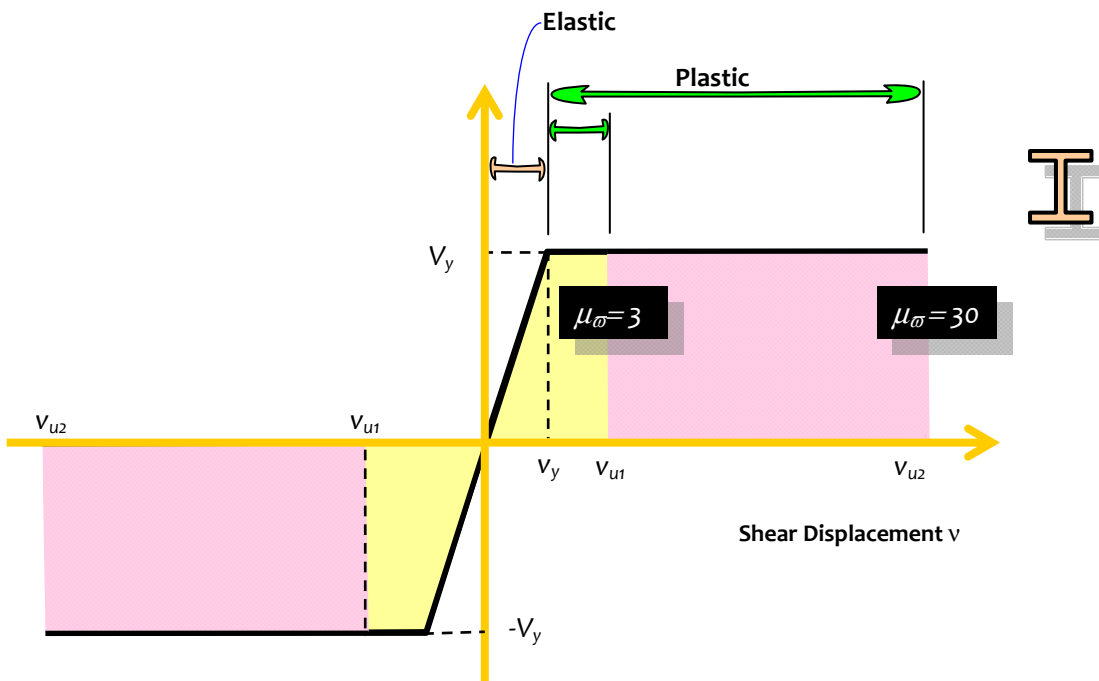


Figure 4.55: Shear force – shear displacement characteristics of the beam and column members used

Five cases of the portal frame are considered (Figure 4.56), namely (1) bare frame, (2) frame with tension brace, (3) frame with compression brace, (4) frame with diagonal X bracing, and (5) frame with Chevron (inverted V) brace. The $M-\phi$, $P-M$, $P-u$ and $V-v$ properties of the members are calculated as per details above and listed in Table 4.1. Figure 4.57 shows the response of these five frames to the lateral displacement loading shown in Figure 4.51. As the section ductility of members increase, the overall ductility of the structure increases. But, in the frame with Chevron bracing, there is a sudden drop in strength also. This is attributed to the detrimental effects of buckling of compression brace leading to large plastic demand on the beam; special detailing is required of the beam to prevent this loss of strength. In general, to improve the overall ductility of the building, efforts must be made to improve the section and member ductilities.

The material ductility of steel is of the order of $(0.25/0.00125 = 200)$. Two cases of member ductility are considered, namely 3 and 30. Based on these, the overall structure ductility is obtained from Figure 4.57 using first onset of nonlinearity as yield, and listed in Table 4.2. For low member ductility of 3, the structure ductility is also of the same range, but for higher member ductility of 30, the structure ductility does not rise to that level, but is smaller.

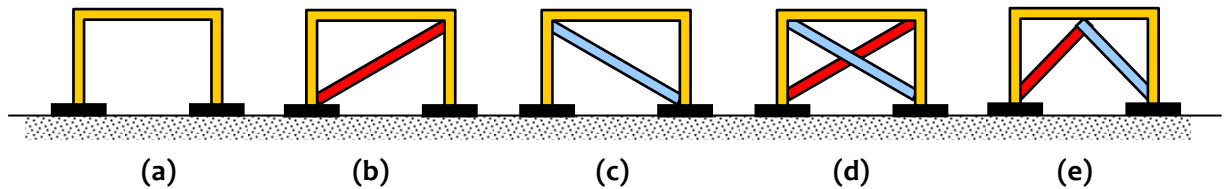


Figure 4.56: Frames considered in understanding implications of ductility on overall inelastic behaviour – (a) Bare frame, (b) Frame with tension brace, (c) Frame with compression brace, (d) Frame with diagonal X bracing, and (e) Frame with Chevron (inverted V) bracing

Table 4.1: Calculated section and member properties of the portal frame members

Section	M_p (kNm)	θ_y $\times 10^{-3}$ (rad)	P_y (kN)	u_y (mm)	P_{cr} (kN)	V_y (kN)	v_y (mm)
ISMB300	171	1.488	1407	5.625	1330	388	7.734
ISMB400	294	1.437	1962	5.000	1923	501	6.875
ISMC200 (X bracing)	52	1.425	705	7.525	499	168	10.347
ISMC200 (Chevron type - double channel)	104	1.425	1411	5.738	1175	356	7.889

Table 4.2: Calculated section and member properties of the portal frame members

Frame	Material Ductility μ	Member Ductility μ_m		Structure Ductility μ_s	
		Case 1	Case 2	Case 1	Case 2
Bare frame	200	3	30	2.93	18.63
frame with tension brace				3.50	16.28
frame with compression brace				3.44	15.78
frame with diagonal X bracing				4.25	33.10
frame with Chevron (inverted V) bracing				1.69	10.62

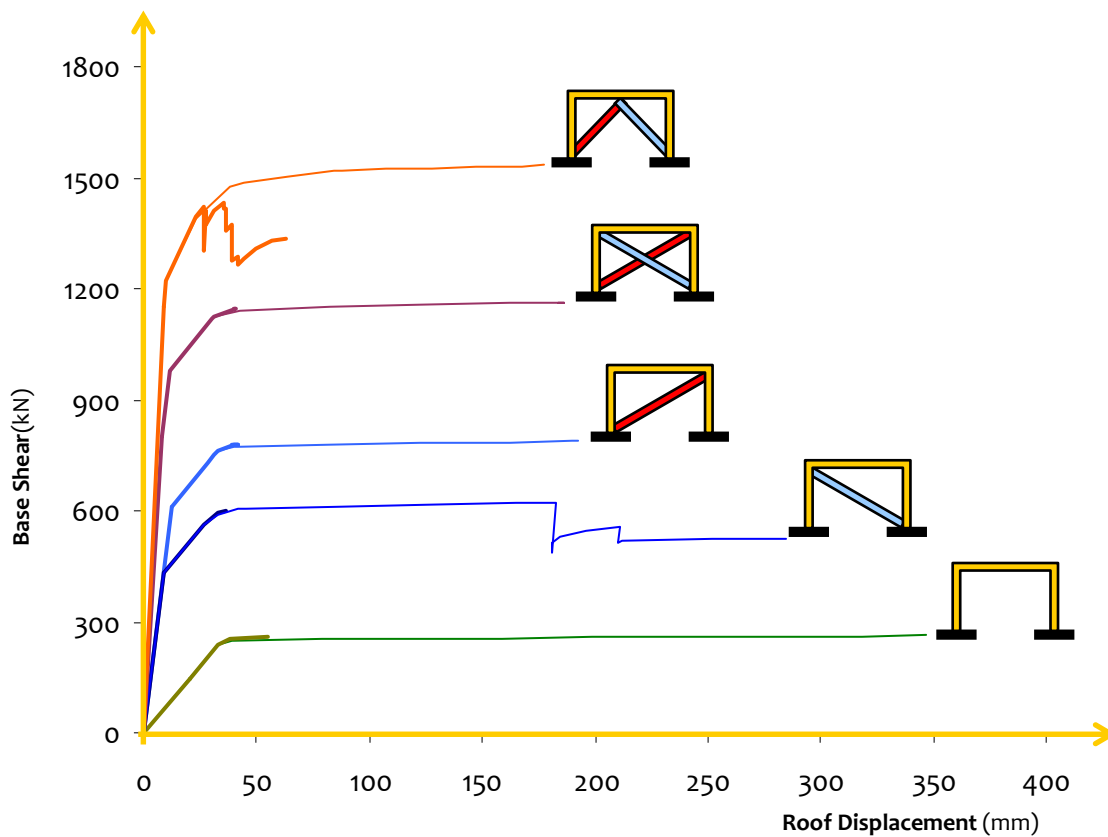


Figure 4.57: Responses of frames considered in understanding implications of detailing on inelastic behaviour: thick lines represent responses with section ductility of 3 and thin lines of 30

4.3.2 Strength Provided in Building and Overall Ductility Demand

If a building remains elastic throughout the earthquake shaking, no damage is incurred; such a building is said to be having no *ductility demand*, i.e., there is no requirement imposed on the structure to undergo any inelastic action. If μ denotes the ductility demand, then for an elastic building $\mu=1$. But, if the building undergoes damage (this happens when it is designed to yield at a lateral force level smaller than the maximum elastic force induced in it under complete elastic action), then it will undergo some inelastic deformation beyond yield deformation. Using the maximum displacement excursion of the building and its yield displacement, its ductility demand can be obtained. By further reducing the design force level, the building yields earlier, and ductility demand increases.

NONLIN computer program (Charney, 1998) is used for arriving at the numbers for the following discussion on influence of design strength of a building on the ductility demand on it. Here, the ductility in focus is the *overall structure ductility*. For the purposes of demonstrating the concept, the 1940 Imperial Valley earthquake (El Centro station; S00E component; 0.31g peak ground acceleration) ground motion is used. Consider a building with fundamental natural period of 1 sec, and initial stiffness of 40 kN/mm. When the building is kept elastic and subjected to the above ground motion, the maximum elastic lateral force induced in it is 5,140 kN and the maximum elastic deformation sustained by the building is 128 mm. Of course, by definition $\mu=1$ for this building. Now, the building is prescribed an upper limit of strength of 3,000kN; its behaviour is defined to be perfectly plastic (with no stiffness) once this force level is reached. The building is subjected to the same ground motion. Now, the maximum lateral deformation sustained by the building is obtained as 108 mm. The strength of the building is reduced further to 1,500 kN. And, the maximum lateral deformation sustained by the building is obtained as 91 mm. The strength of the building is reduced once more to 750 kN. All these results are presented in Table 4.3 along with

ductility demand μ and sketched in Figure 4.58. The broad observation is that the ductility demand on the building increases with reduction in the yield force. Also, ductility demand μ is in the same range as strength ratio R_μ (of maximum force on the building, if it remains elastic, and the prescribed yield force). Of course, the values of the analyses depend on the characteristics of the ground motion considered. For another *similar* ground motion, numbers will be different, but same conclusions are expected.

Table 4.3: Results of NONLIN analysis of a building with T=1s subjected to 1940 Imperial Valley earthquake ground motion

Case	Initial stiffness K (kN/mm)	Yield strength H_y (kN)	Maximum displacement sustained Δ_{max} (mm)	Yield displacement $\Delta_y (=H_y/K)$ (mm)	Ductility demand $\mu (= \Delta_{max}/ \Delta_y)$ -	Strength Ratio R_μ (= $H_{e,max}/ H_y$) -
1	40	5140 (= $H_{e,max}$)	128	128	1.00	1.00
2		3000	108	75	1.44	1.71
3		1500	91	37.5	2.42	3.42
4		750	122	18.75	6.5	6.85

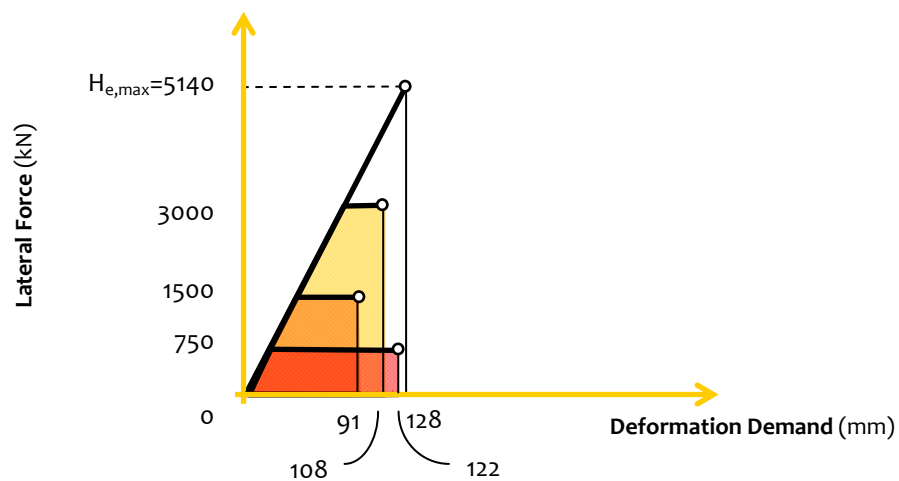


Figure 4.58: Deformation Demand on Building with T=1s subjected to 1999 Chamoli earthquake ground motion: Reducing the yield strength, increases the deformation demand

4.3.3 Capacity Design of Buildings

Along with the development of different strength-based design procedures, an important design philosophy was developed by the 1970s – the development of *capacity design concept* furthered the development of earthquake-resistant design. This requires a hierarchy of structural component strengths in the design of structures, that aims to ensure that inelasticity is confined to predetermined and preferred structural components. Failure modes that result in non-ductile structural behavior are delayed by providing higher resistance to such modes.

(a) Displacement Loading

Design for earthquake effects essentially involves controlling mobilization of internal forces in members due to imposed deformations within the building. This is because during an earthquake shaking, the building is subjected to random motion of the ground at its base. This, in turn, induces stiffness forces in members. In structural design methods that use *force* as the basis, usually in beams, each force component is designed for independently. For example, in a simple beam with ends clamped and subjected to only transverse forces (as it happens under dead and live loads), the bending moment and shear force induced are designed separately; it is ensured that the section capacity in flexure and shear are more than the respective demands. Here, both the possible failure modes (flexure and shear) are precluded independently through design.

On the other hand, if the same beam is subjected to a relative transverse *displacement* at its two ends (as it happens under earthquake shaking), the bending moment and shear force mobilized at a section of the beam are interdependent, and their magnitudes depend on the relative displacement between the two beam ends for an elastic system. For a beam made of any real material having a finite strength, the maximum magnitudes of bending moment and shear force mobilized depend on the limiting resistance of the cross-section of the beam. At a particular level of displacement loading, either of the limiting resistances of the beam may be reached in flexure or shear, and failure in that particular mode occurs first. Thus, there is a need to design the building, or the beam (in this case), such that the ductile (under-reinforced flexural action) mode of failure precedes the non-ductile or brittle (shear) mode of failure. This is particularly important since the maximum level of displacement loading during an earthquake shaking is not known beforehand.

The idea is elaborated through by the *Ductile Chain Analogy*. Consider a chain with all links made of brittle materials except one central link made of ductile material (Figure 4.59). Now, when a relative displacement of Δ is applied between the last links at either end of the chain, the same force F is transferred through all the links. As more and more displacement is applied, strain, stress, and finally internal force are generated in each of the links until eventually the chain breaks when the link with the least strength breaks. If this link is *ductile* link, then the overall behaviour of the chain is *ductile*. This is easily achieved by making the ductile link the *weakest link* (i.e., its capacity to take load is less than that of the brittle link). Also, the chain will show large final elongation because ductile materials and systems have large rupture strain capacity compared to brittle materials and systems. Instead, if a brittle link is the weakest one, the chain will fail suddenly and show small final elongation. Therefore, to make a chain ductile, the ductile link has to be made the weakest link.

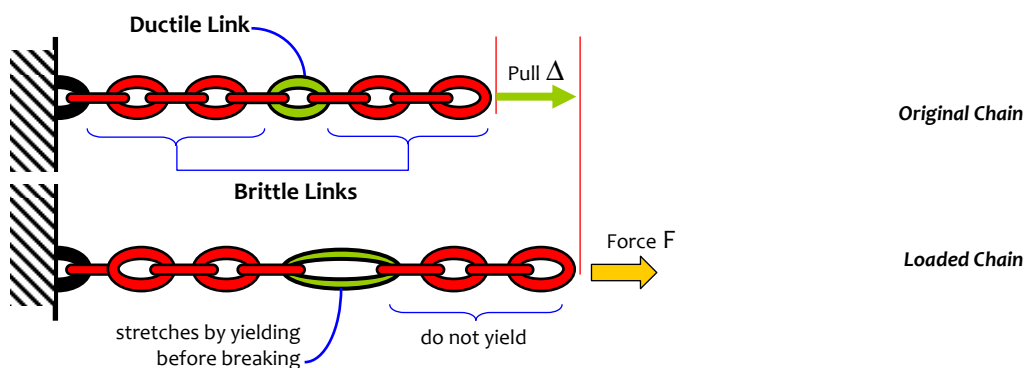


Figure 4.59: Chain Analogy: Ductile chain design

With the chain analogy in the background, it is important to identify first the various damage modes affecting the final collapse of RC buildings, and ways to control them. The collapse mechanism is primarily governed by two sets of information, namely, (i) location of inelastic hinges, and (ii) types of hinges. A member in a RC frame building is typically under the action of axial force, bending moment and shear force. For a member under pure axial compression, the axial load-deformation relation is shown in Figure 4.60a. Prior to reaching maximum load, softening occurs of the response curve due to spalling of unconfined or cover concrete. After reaching the maximum load, sudden drop occurs in load carrying capacity due to uniform crushing of confined concrete in compression. Similarly, shear failure is brittle in nature (Figure 4.60b). But, under-reinforced flexural behaviour is ductile with strain-hardening characteristics (Figure 4.60c). Therefore, it is important that the member be so designed that the under-reinforced flexural action is weakest among the three possible modes of damage and failure.

Importance of controlling the collapse mechanism is best illustrated by the *Pot Analogy*. Consider an earthen pot with holes in it. If the desirable action is to fill the pot with water up to its brim, all the holes starting from the one at the *bottom* have to be plugged sequentially to prevent the water from leaking out prematurely (Figure 4.61). Likewise, all undesirable modes of failure (*i.e.*, all the *brittle* ones, like water leaking from the holes) need to be prevented from occurring before the desirable mode of failure (*i.e.*, the *ductile* ones, like water overflowing from the top).

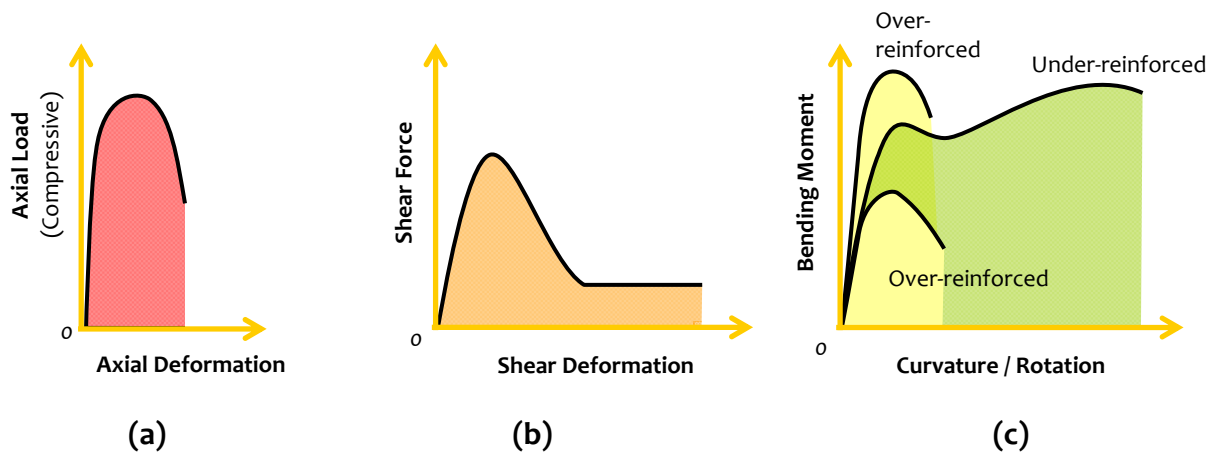


Figure 4.60: *Inelastic hinges*: Moment hinge demonstrates the largest ductility

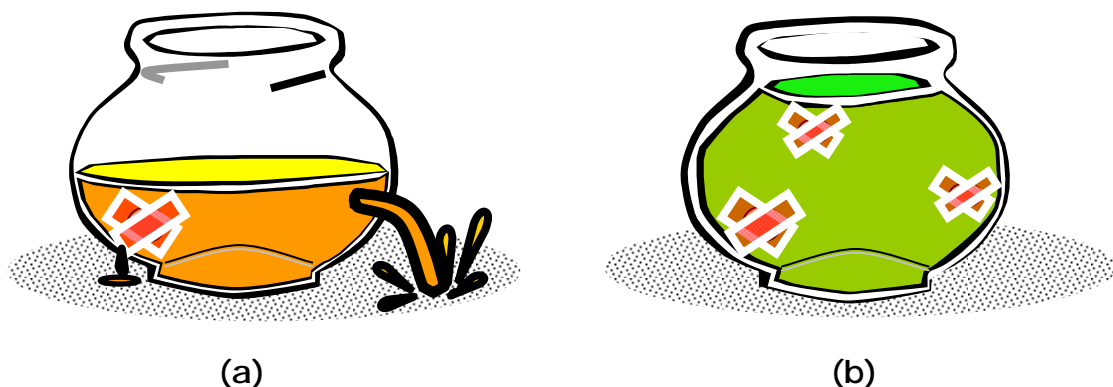


Figure 4.61: *Pot analogy*: Pot fills when all holes are plugged - (a) un-suppressed undesirable modes of failure, and (b) suppressed undesirable modes of failure

(b) Capacity Design Concept

The essence of capacity design procedure is to set a strength hierarchy *within each of the structural members*, and then in the structure as a whole. In addition, it relies heavily on ductility at selected sections, and then, in select members. The first step in capacity design procedure addresses setting a strength hierarchy *at the member level*. For example, under strong seismic shaking, a beam in RC moment resisting frame (MRF) is subjected to interdependent bending moment and shear force. Failure in shear is non-ductile while under-reinforced flexural action is a ductile mode. Thus, capacity design procedure aims at designing the beam shear capacity to be more than the limiting equilibrium compatible shear arising out of under-reinforced flexural action at the two beam ends (Figure 4.62). The maximum probable equilibrium compatible shear demand V_{Ω} then is proportional to $M_{\Omega 1}$ and $M_{\Omega 2}$, the maximum overstrength based under-reinforced plastic hinge moment capacities of the beam section mobilized at the two ends, in addition to the shear force due to imposed gravity loads like dead and live loads. The beam is then designed to have a *nominal* shear capacity V_n larger than V_{Ω} . The nominal shear capacity V_n uses safety factors or resistance modification factors depending on the design method used.

The next step in capacity design procedure addresses setting a strength hierarchy *at the structure level*. For example, since ductility is easier to achieve in beams than in columns in a RC MRF, capacity design procedure aims at adjusting column strength to be more than the strengths of the beams framing in to the columns. This is done to achieve a condition where inelasticity in the form of energy dissipating ductile plastic hinges is confined to the beams, and the columns remain elastic. This idea led to the development of *strong-column weak-beam* (SCWB) design philosophy (Figure 4.63). Assuming that under earthquake shaking, columns undergo double curvature bending and that the points of contra-flexure occur at mid-heights, column shear V_c is proportional to $M_{\Omega 1}$ and $M_{\Omega 2}$, the maximum overstrength based under-reinforced plastic hinge moment capacities of the beams adjoining the beam-column joint. The underlying assumptions here are that columns do not form plastic hinges (due to SCWB design), and the beams do not carry axial forces.

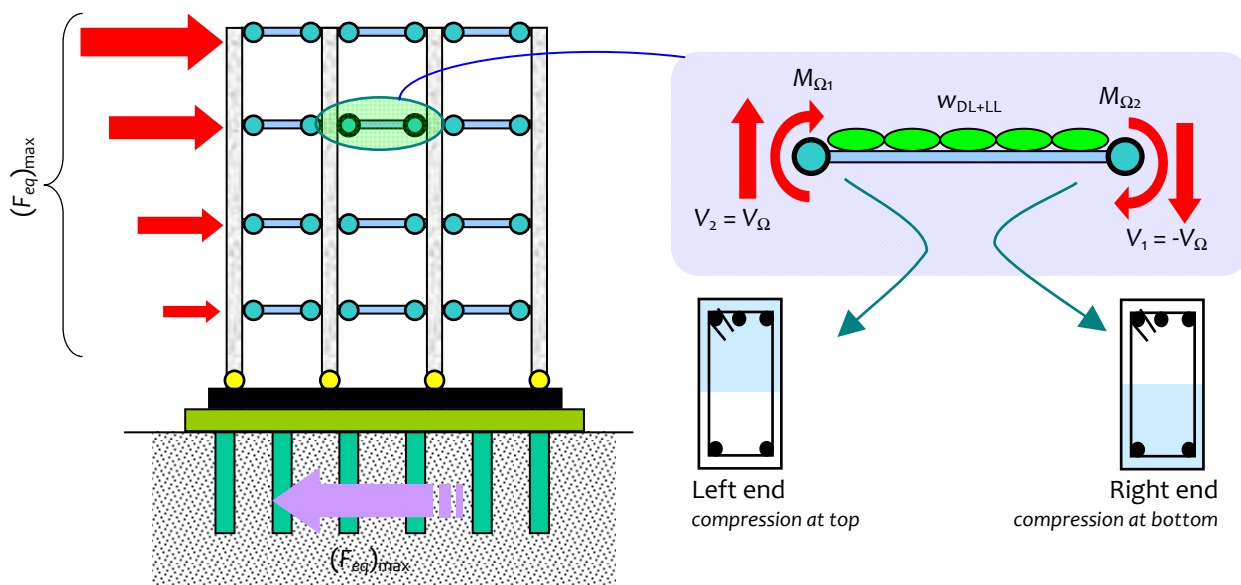


Figure 4.62: Capacity design of beam: Moment actions when beam swings to the left, and will reverse if the beam swings to the right

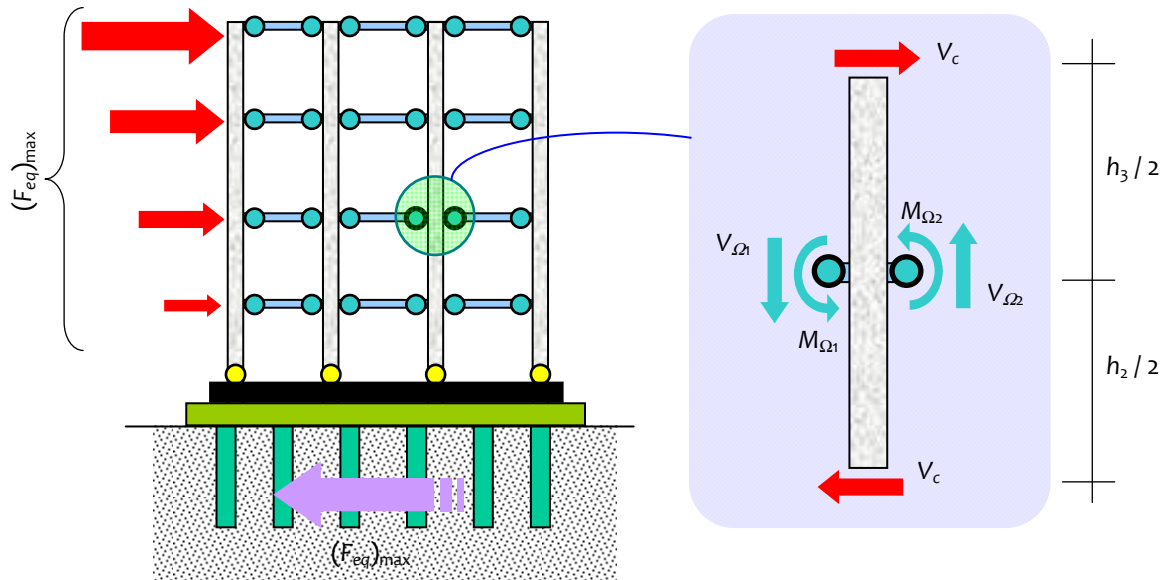


Figure 4.63: Capacity design of column: Moment hinges form in the beams and not in the columns

Further, since the column is finally supported by the foundation, the foundation is designed to have strength higher than that of the supported column. This is very intuitive since the building component supporting is designed to have higher strength than the building component being supported. This setting of strength hierarchy is done at the structure or global level, which is achieved through reinforcing the joints in between two components of a building to ensure smooth flow of forces between them. For example, beam-column joints must be designed to have sufficient strength to allow mobilization of maximum beam-end forces, and to safely transfer them to the column.

Beam-column joints have finite stiffness and finite strength just as the adjoining designed beams and columns. This warrants that these joints be designed to preclude any damage or failure in them so as to maintain the force flow path between the beams and columns. In general, whenever size of these joints is limited, a variety of failure limits the efficacy of the whole system. These are:

- (i) *Spalling of cover concrete*: When the ratio of area of cover concrete to the confined joint core concrete becomes comparable, spalling of the cover concrete results in significant reduction in the load carrying capacity of the adjoining beam and column.
- (ii) *Anchorage failure longitudinal beam bars* : Inadequate anchorage of longitudinal beam bars passing through or coming into the joint results in strength deterioration and significant permanent deformation in the adjoining beams. Large plastic rotations occur at the column face resulting in large drop in the stiffness of the beam, and hence the structure.
- (iii) *Shear failure of joint core* : This result in severe distortion of the joint region causing large lateral drifts of the building frames. Shear failure of the joint core occurs due to either diagonal compression failure or diagonal tension failure.

Beam-column joints are subjected to two primarily loading types, namely of (i) *gravity loading* type, and (ii) *seismic loading* type (Figure 4.64). For an interior joint, in the former load case, the top beam bars on both sides of the joint are in tension, while in the later, the top beam bars on one side are in compression and those on the other side are in tension. If the beams adjoining the joint are of the same size and have the same bars, and have plastic hinges formed in them under strong seismic shaking, the joint in the latter case has the responsibility of providing almost twice the development length for the beam bars. If it is not made available, beam bars can fail in bond slip inside the joint core. Besides, in the seismic loading case, second critical effect is that due to the *diagonal tension* and *compression* actions. The joint core has to be designed for these diagonal tension-compression force fields. Further, in the seismic loading case, the plastic hinge condition at the beam ends results in a third concern, which is with respect to the shear stress in the beam-column joints. From equilibrium, the horizontal shear force V_{jh} in the joint depends on the actual forces in the top bar at its two ends. These bar end forces includes the overstrength factor of steel bars used; this factor, denoted by Ω_s , is recommend a value of 1.25 by some seismic design codes, suggesting that the stress in the steel reinforcement bars to be used is $1.25f_y$. The joint must be capable of resisting this shear V_{jh} . The best way is to resist it by providing large area in joints (implying use of large sized columns). The next method of resisting this is by providing horizontal closed ties in the joint region. Similarly, deign is required to ensure that vertical shear stress V_{jv} also is accounted for.

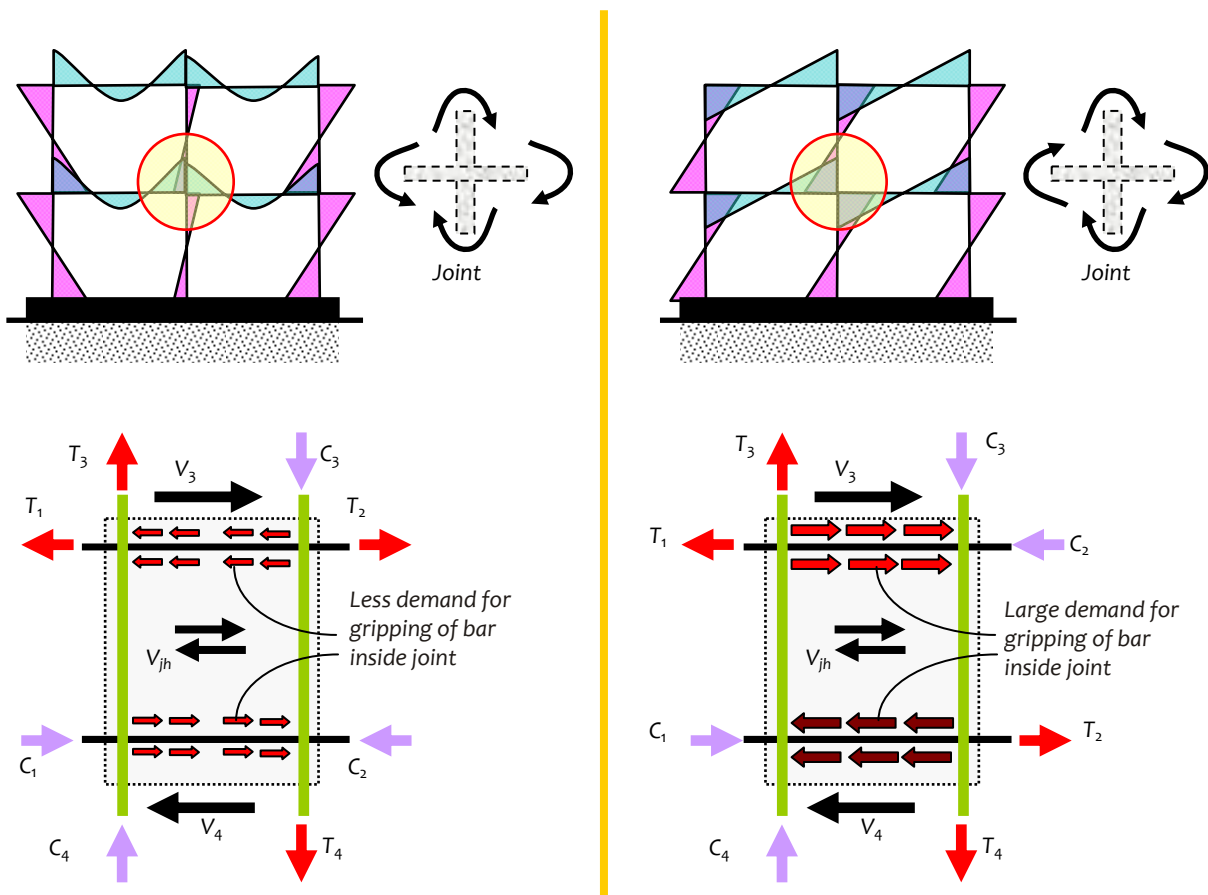


Figure 4.64: Capacity design of beam-column joint: Bond slip and shear failure of the joint need to be prevented

4.3.4 Distribution of Damage in Buildings

All damage of all types are not acceptable in seismic design of buildings. In RC buildings, it is flexural under-reinforced type, and in steel buildings, it is flexural tensile yielding or shear yielding type damages that are acceptable. Damage of the desirable kind should be distributed in the whole building. This ensures that

- (1) More members contribute to the ductility of the building;
- (2) Many members undergo inelastic deformation, but each to a limited level; no one member is required to undergo excessive amount of inelastic action;
- (3) Damage is not localized to limited areas; and
- (4) More members absorb the earthquake energy input to the building.

Of course, it will happen, if the member that enters the inelastic range of behaviour first continues to deform inelastically until many more members reach their inelastic deformation capacity. Often, this is a factor that limits the overall inelastic deformation capacity of the building, if this first hinge forming does not have sufficiently large inelastic deformation capacity, and hence its overall structure ductility. On the contrary, if the damage is localized to a portion of the building or to a few members of the building, then it is likely that a few members reach the limit of their deformation capacity, much before the other members even get into the inelastic range. Thus, the building may not get the advantage of the presence of many members that can contribute to earthquake energy absorption.

Once it is ensured that the damage is distributed over a large number of members of the building, the interest would shift to ensuring that the collective set of members undergoing inelastic action does not form undesirable local/global collapse mechanisms (Figure 4.65). Firstly, the collapse mechanism should include as many members of the building as possible. Secondly, the mechanism should seek as minimum inelastic action as possible in the vertical members (*e.g.*, columns). The importance of strength hierarchy of members is realized here. Only one overall collapse mechanism is acceptable – the one including beam inelasticity *throughout the building*.

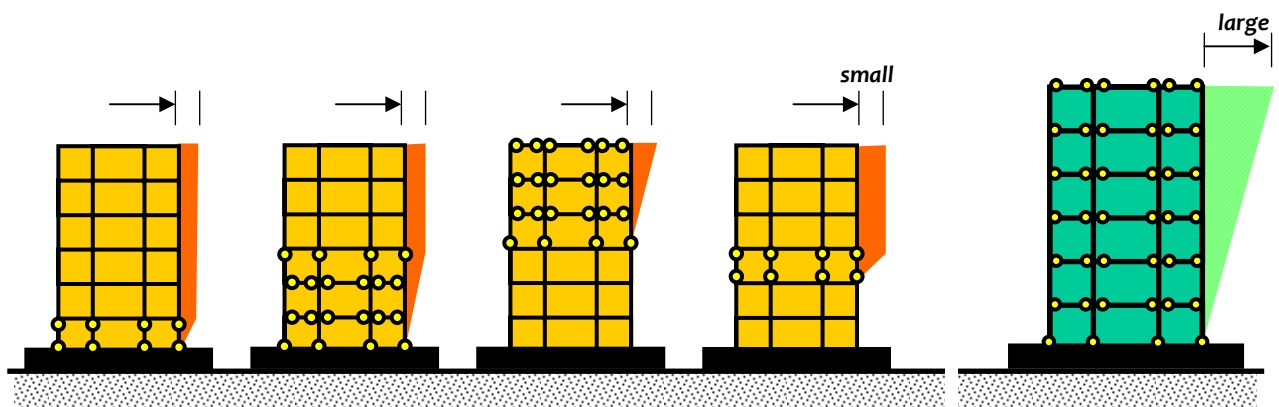


Figure 4.65: Local damage versus global damage: overall lateral deformation ductility is larger in the latter

(a) The Open Ground Storey Buildings

One classic *non-example* of good practice of seismic design is the way buildings in India are built with open ground storeys. These buildings are characterized by

- (a) The conspicuous absence of unreinforced masonry infills in the ground storey, and presence of the same in all storeys above;
- (b) The use of only brittle 230mm×450mm columns with prescriptive non-ductile reinforcement detailing scheme; and
- (c) The absence of any structural grid in plan of the building, and some irregularities in the structural systems in elevation.

Typically, the shear force increases downwards along the building height; it is maximum at the base of the building. This requires the building to be stronger downwards along the height. But, the practice of constructing open-ground storey buildings does not ensure this. The behaviour is radically different of this moment frame with unreinforced masonry infill system from the bare frame model that is assumed in design practice.

Four buildings are considered for comparison, namely:

- (1) The benchmark 5-storey building with infill masonry in the frame panels (Figure 4.66a);
- (2) The bare frame of the benchmark building (Figure 4.66b); and
- (3) The benchmark 5-storey building with infill masonry in the frame panels of the upper four storeys only (with the ground storey left open) (Figure 4.66c); and
- (4) The benchmark 5-storey building with infill masonry in the frame panels of the upper four storeys only (with the ground storey left open) and enhanced design of beams and columns of the ground storey as suggested in IS:1893 (Part 1)-2007 (Figure 4.66d).

Pushover analysis is performed for these four buildings. The lateral load deformation curves of the four buildings (Figure 4.67) show that the strength of the bare frame buildings is even smaller than that of the open ground storey building, which is brittle and does not have much inelastic deformation; strengthening does seem to help of the beams and columns in the ground storey. Also, the collapse mechanism of these buildings (Figure 4.68d) indicates that the entire nonlinearity is localized above the ground storey.

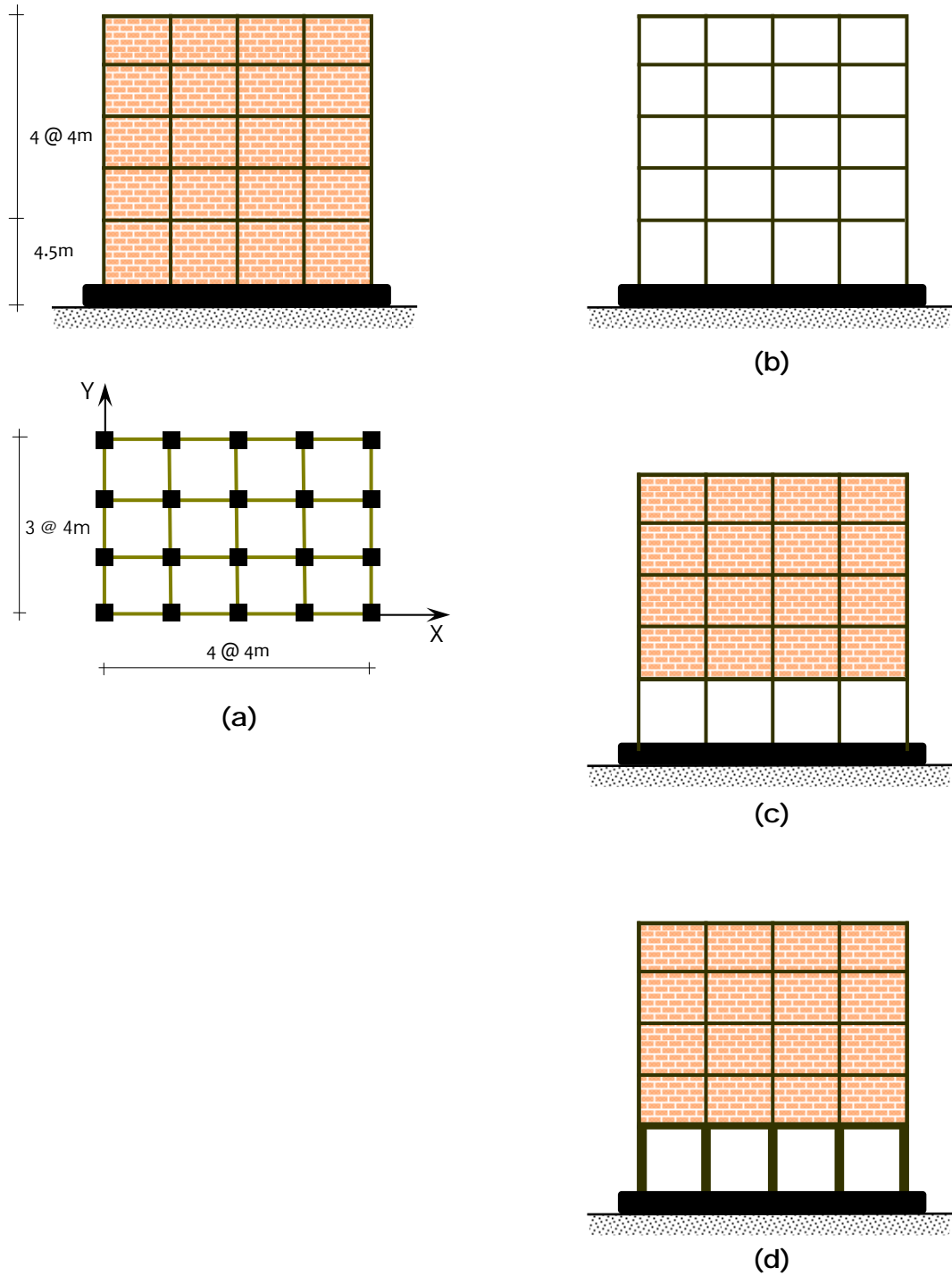


Figure 4.66: Open Ground Storey Buildings: Benchmark 5-storey building with (a) infills in all storeys, (b) with no infill masonry in any storey, (c) infill masonry in upper four storeys only, and (d) infill masonry in upper four storeys only and enhanced member designs in ground storey

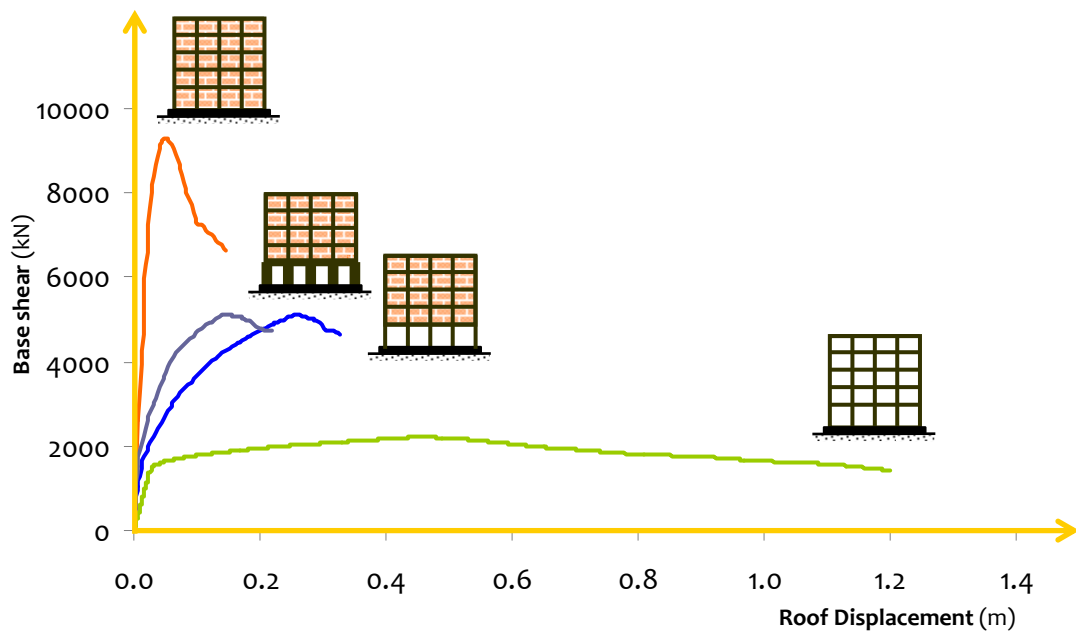


Figure 4.67: Open ground storey building: Influence of infill masonry significant on overall ductility

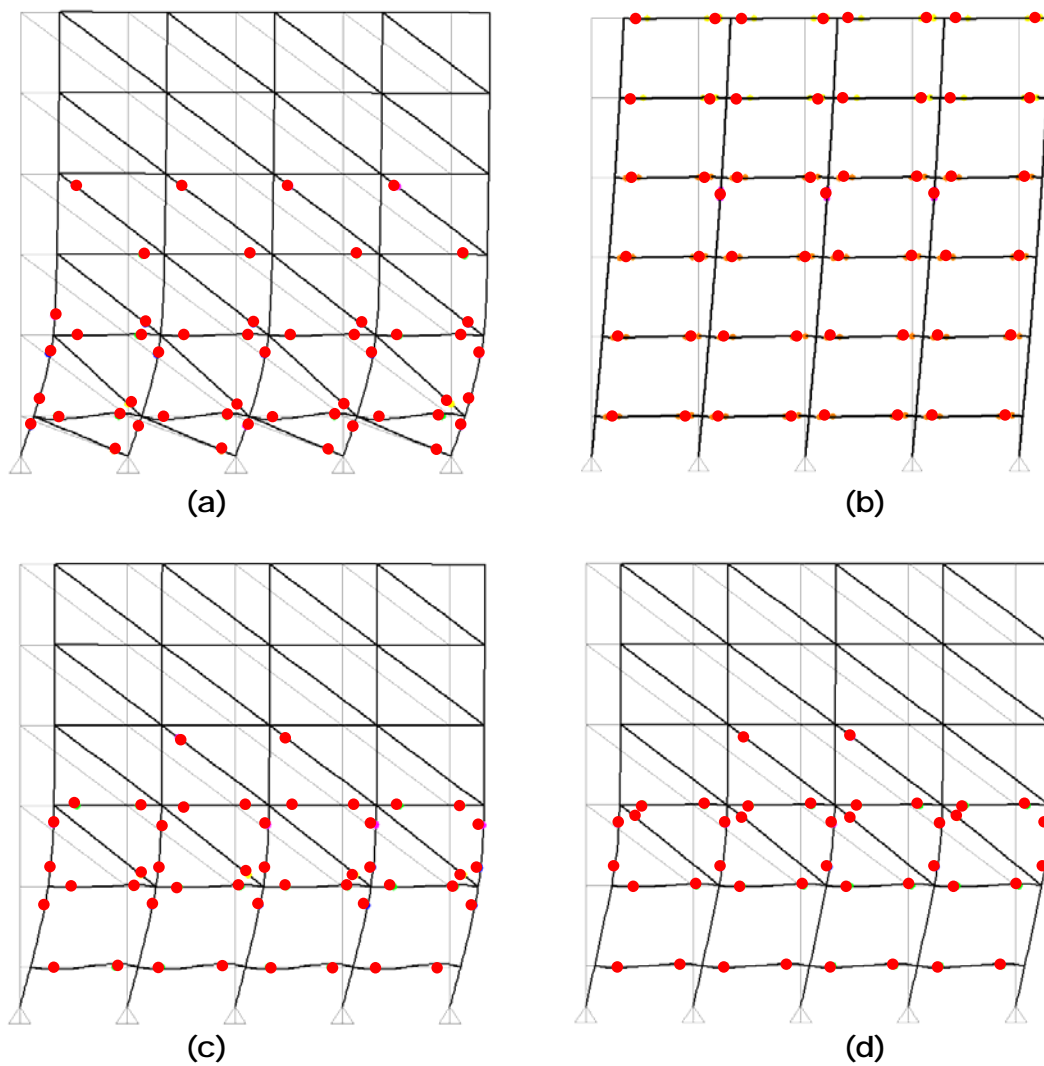
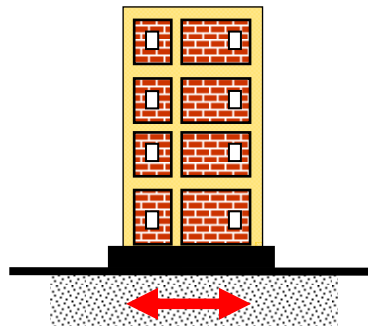
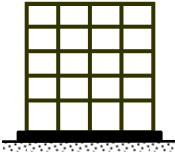
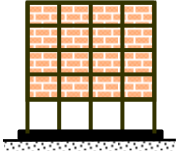
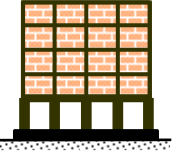


Figure 4.68: Open ground storey building: Damage is localized to members in the ground storey alone, which is not captured by the bare frame analysis

Pushover Analysis of Buildings
Effect of Capacity Design



<p><i>Bare Frame</i></p> 	<p><i>Open Ground Storey</i></p> 	<p><i>Enhanced Beams and Columns in Ground Storey</i></p> 
<p><u>Inelasticity distributed in beams</u></p>	<p><u>Inelasticity in columns in open ground storey</u></p>	<p><u>No inelasticity in columns in open ground storey</u></p>
<p><i>Click on the 3 items above to see the sequence of hinge formation</i> Best when viewed using Windows Media Player</p>		

(b) Strong Column - Weak Beam Design

Strong-column weak-beam (SCWB) design philosophy is critical in controlling the overall ductility of a building by distributing damage over large number of beams to achieve an ideal collapse mechanism under strong earthquake shaking. This is to ensure that damage to columns is eliminated, because columns are required to transfer loads (largely the gravity loads) *even after an earthquake*. This is achieved through *capacity design* of columns. The important steps involved are:

- (a) Prevent brittle shear failure of individual beams and columns through capacity design;
- (b) Prevent brittle shear or anchorage failure of joints through proper design and detail; and
- (c) Ensure that the *design flexural capacity of columns* M_{cD} framing into any joint is greater than the *overstrength flexural capacity of the beams* $M_{b\Omega}$ framing into that joint, *i.e.*,

$$\beta_{SCWB} = \frac{M_{cD}}{M_{b\Omega}} > 1.0. \quad (4.4)$$

Many design codes recommend this but require that the *design flexural capacity of columns* M_{cD} framing into any joint is greater than the *design flexural capacity of the beams* M_{bD} framing into that joint, *i.e.*,

$$\beta = \frac{M_{cD}}{M_{bD}} > 1.0. \quad (4.5)$$

Values prescribed in international codes for column to beam *design* strength ratio β varies between 1 and 2. But, failure of numerous code-compliant buildings during past earthquakes by formation of storey mechanism raises concern on the requirements. Research on the subject indicates:

- (a) Current code provisions are inadequate to prevent column hinges;
- (b) Likelihood of storey mechanism decreases with increase in column to beam strength ratio;
- (c) Column to beam strength ratio required for formation of sway mechanism increases with increase in the intensity of ground motion; and
- (d) In addition to column to beam strength ratio, beam flexural strength and beam ductility capacity govern the behaviour of the building under severe shaking.

Consider a 5-storey RC moment resisting frame building located in Indian seismic zone V with 6 bays along X-direction and 4 along Y-direction, with bay length of 4m along both plan directions and storey height of 3m. The site of the building is considered to be soft soil stratum. Live and superimposed dead loads considered are 2kN/m² and 1kN/m², respectively. The contribution masonry infill is considered in the mass of the building, but neglected in estimation of stiffness. Equivalent lateral earthquake load on the building is calculated as per IS 1893 (Part 1) - 2007. The building is designed as per standard load combinations. All beams and columns are designed for shear, such that no shear failure is likely to occur prior to flexural failure. Based on design, uniform sizes are adopted for all beams (300×400) and columns (400×400). Flexural overstrength moment capacity of the beam is estimated to be 83kNm.

Moment capacity of columns in the building is progressively increased (keeping constant the beam capacity) to attain column to beam strength ratios of 1.2, 1.6, 2.0, 2.4, 2.8, 3.2 and 3.6. Increase in the column to beam strength ratio increases (a) lateral load (base shear) capacity of the building, and (b) lateral deformation and ductility capacity of the building (Figure 4.69). The corresponding locations of damage are shown in Figure 4.70 of the buildings with different strength ratios. The major observations from the study are: (a) column to beam strength ratios of 1.2 to 3.2 are not adequate to prevent yielding of columns or undesirable storey mechanism, (b) increase in strength ratio helps more number of beams to undergo inelastic actions and thereby increase buildings' energy dissipation capacity.

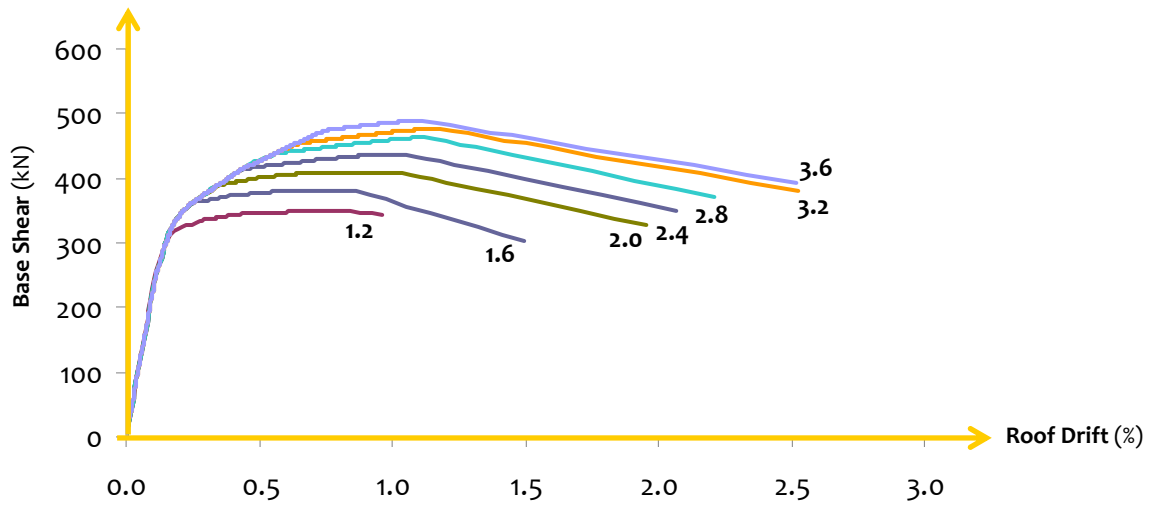


Figure 4.69: Capacity curves: Global ductility increases with increase in column to beam strength ratio in moment frames

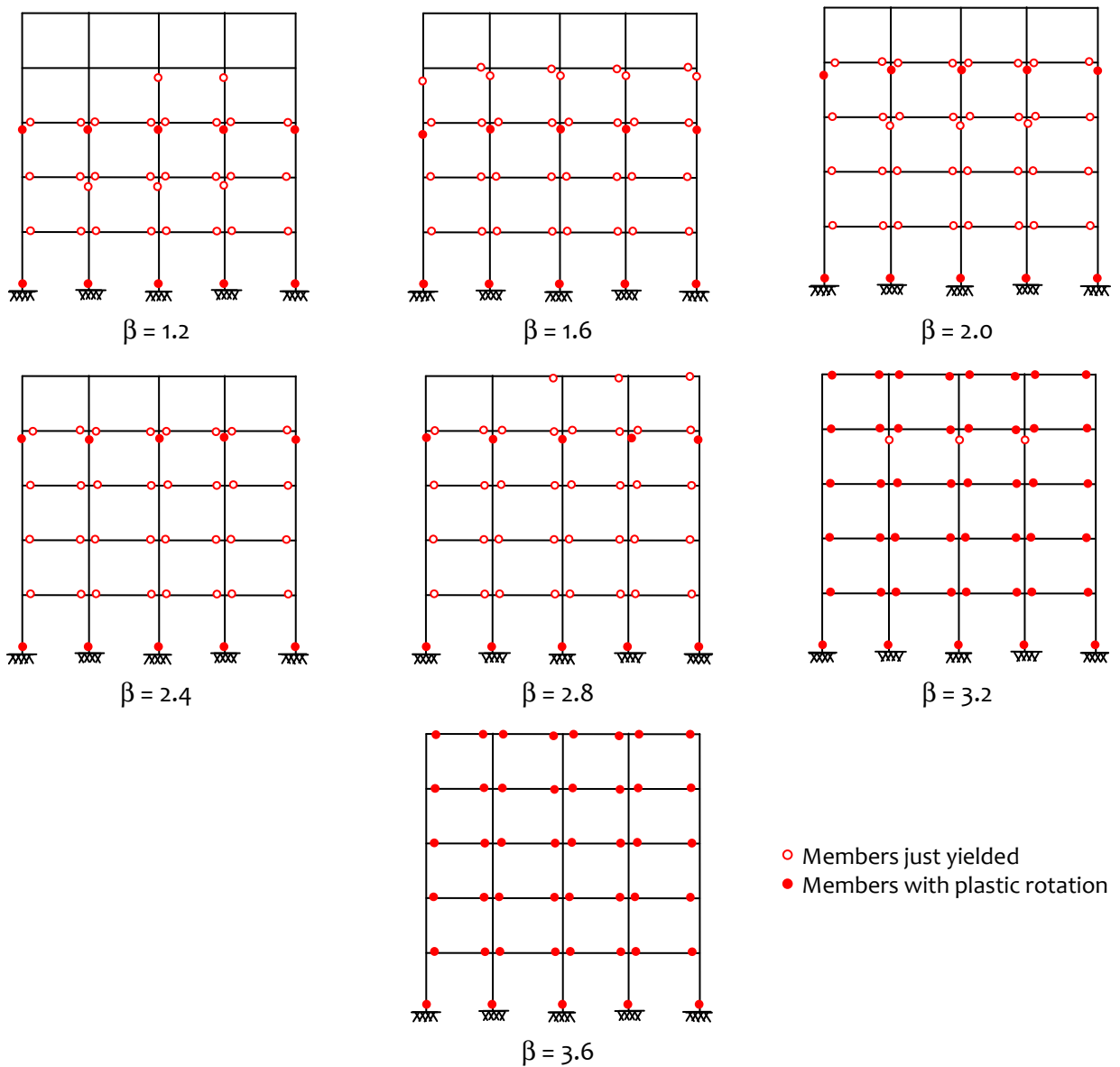


Figure 4.70: Collapse mechanism: Ideal sway collapse mechanism can be achieved at higher column to beam flexural strength ratio

The sequence of hinge formation is critical in a building in addition to its capacity curve and the location of plastic hinges in the building. The sequence of hinge formation is demonstrated in Figure 4.71. The Y-axis in the graph represents the number of all possible hinge locations (in beams and columns) while load step of the pushover analysis is shown on the X-axis. At each step, flexural demand to capacity ratios (DCR) are calculated at every possible hinge locations and are sorted such that the one with highest DCR is at the top and the one with lowest DCR is at the bottom. Further, beam hinge locations are designated the green colour while column hinge locations the saffron. Thus, although 9 column hinge locations had higher DCR in the first step, finally (at the last step of the pushover analysis) all beam hinge locations end up with higher DCR than the column hinge locations with progressive yielding and associated redistribution. Thus, Figure 4.71 denotes the sequence of hinge formation of the building with column to beam strength ratio of 3.6, *i.e.*, one with ideal collapse mechanism.

Further, the design *column-to-beam strength ratio* required may seem sufficient for low to moderate intensity of shaking as obtained from *nonlinear static pushover analysis* to achieve ideal collapse mechanism in moment resisting frames. But, the strength ratio required is *much larger* to prevent storey mechanism or yielding of columns under actual *strong earthquake ground shaking*. Results of *nonlinear dynamic time history analyses* on the study building shows these large values (Figure 4.72). In this study, three ground acceleration time histories (1991 Uttarkashi component N75E; 1940 El Centro component S00E; 1989 Loma Prieta component Corralitons Channel 1 N90E) are used. Each of these is scaled to three levels of PGA, namely 0.36g, 0.72g and 1.08g. It may be impractical or uneconomic to design *moment frame* buildings with such large column-to-beam strength ratios; *structural walls* provided in these moment frame buildings will help reduce this requirement significantly and thereby ensure safety of these buildings.

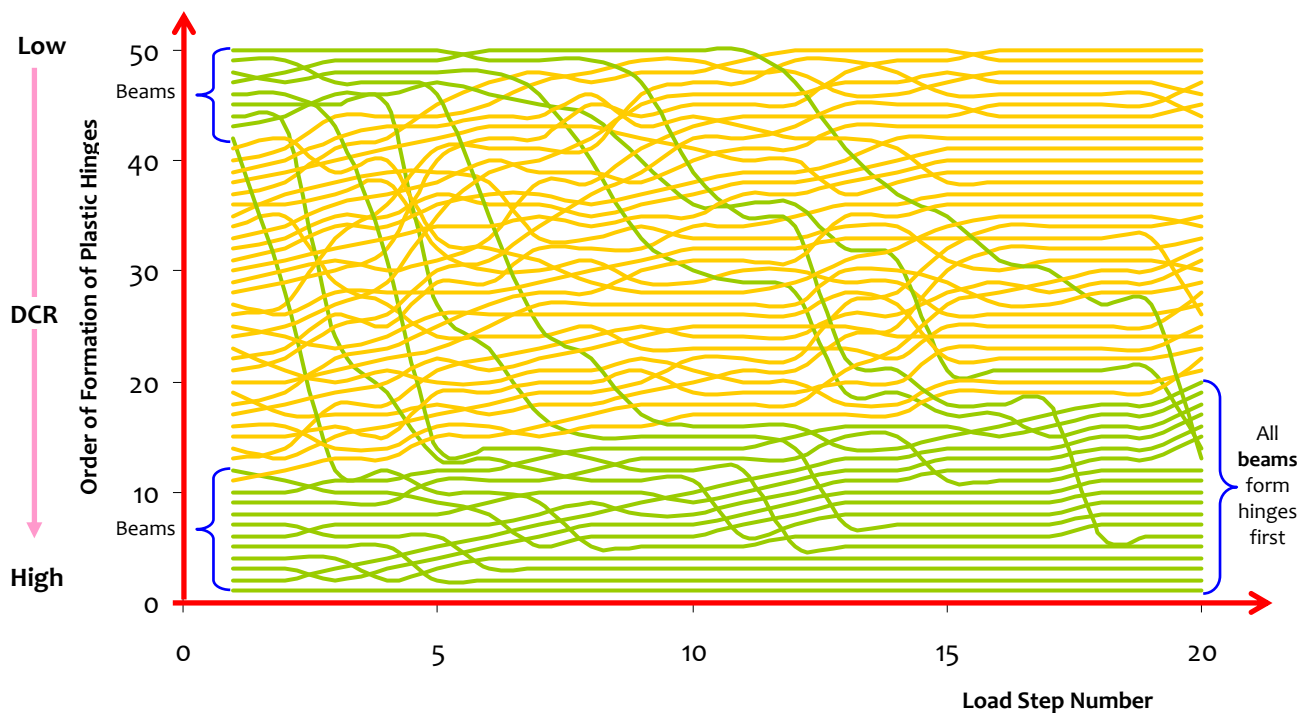


Figure 4.71: Sequence of hinge formation in moment frame: Hinges should form in beams (GREEN) before in columns (SAFFRON)

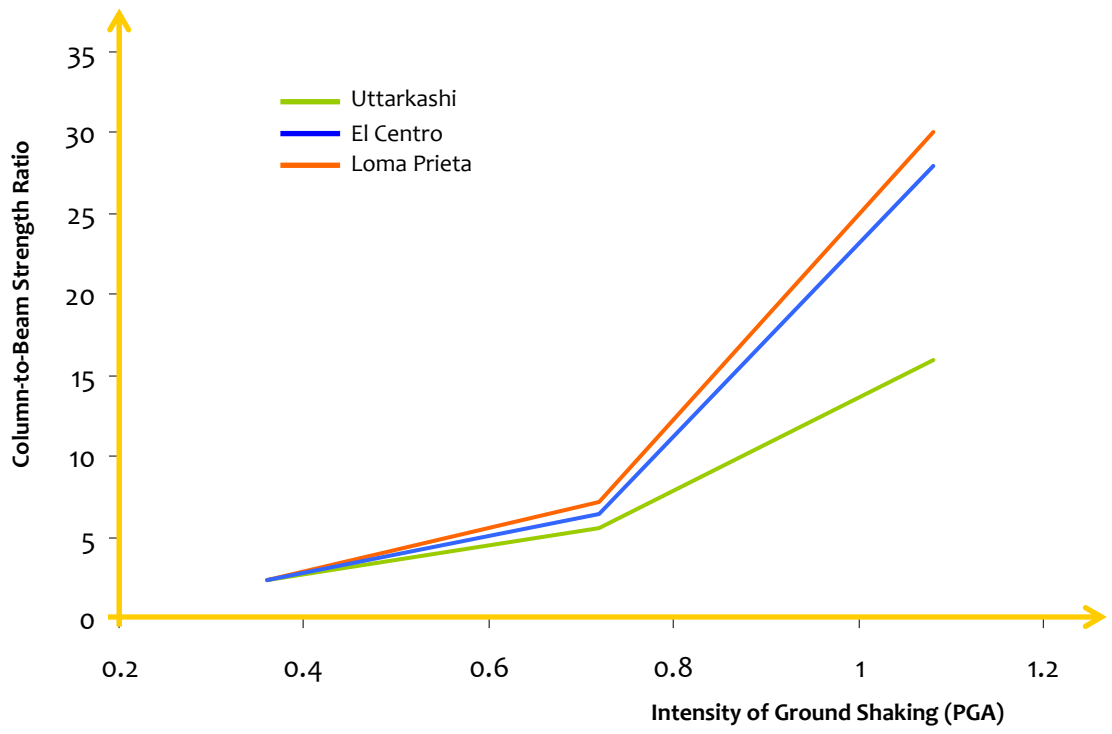
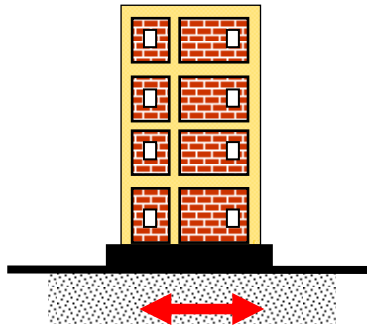
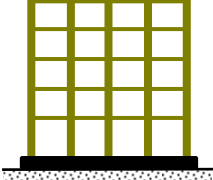
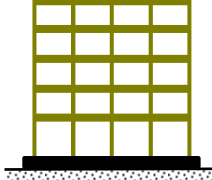


Figure 4.72: Prevention of storey mechanism in moment frame: Required column-to-beam strength ratio for SCWB design increases with intensity of earthquake shaking

Animation Set 409

Nonlinear Inelastic Time History Analysis of Buildings Effect of Column to Beam Strength Ratio (Collapse Mechanism)



<p>Column-to-Beam Strength Ratio 2.8</p> 	<p>Column-to-Beam Strength Ratio 1.6</p> 
<p><u>Beam Sway Mechanism</u></p>	<p><u>Mixed Mechanism with Column Hinge</u></p>
<p>Click on the 2 items above to see the sequence of hinge formation Best when viewed using Windows Media Player</p>	

**(c) Excessive Ductility Demands owing to Pounding
from Adjacent Building / Adjacent Part of same Building**

The seriousness of pounding is explained in Section 3.4.3 between two parts of the same buildings or two parts of the same buildings with a small *expansion gap* between them. The inelastic aspects of this problem are discussed here. For this, three buildings are considered, namely:

- (1) The benchmark 5-storey building with another identical building adjoining the same (Figure 4.73a);
- (2) The benchmark 5-storey building with another 4-storey building (of the same total height, but of different storey heights in the upper three storeys) adjoining the same (Figure 4.73b); and
- (3) The benchmark 5-storey building with another 10-storey building (of the same total height and same storey heights, and additional five 3m storeys above) adjoining the same (Figure 4.73b).

The structural frame members, dimensions in plan and masses are identical in all floors in all buildings. Time history analyses are performed of these three buildings subjected to 1940 El Centro earthquake ground motion (S00E component; 0.31g peak ground acceleration). Results show that adjoining buildings pull away from each other (Figure 4.74), collide with each other, and cause significant pounding of the two adjoining blocks; the impact force at the roof level at the interface node is 1,363 kN in one of two buildings impacting on each other (Figure 4.75). Columns at the junction sustain significant impact. The problem is aggravated especially where storey heights of the two adjacent buildings do not match; slab from one buildings impacts on the column at an intermediate height.

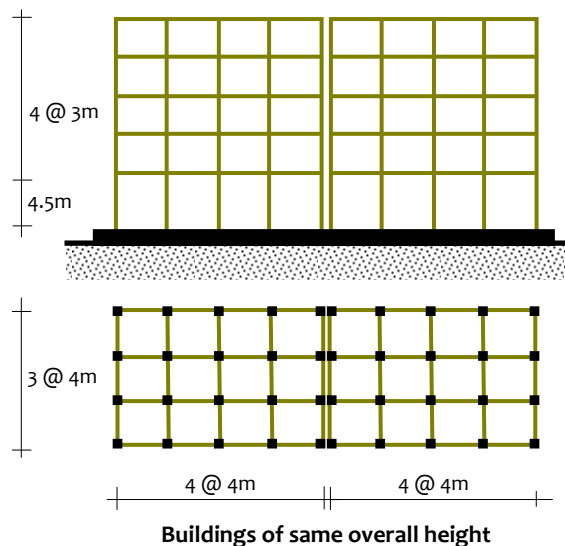


Figure 4.73: Building considered to study pounding: Two identical 5-storey buildings

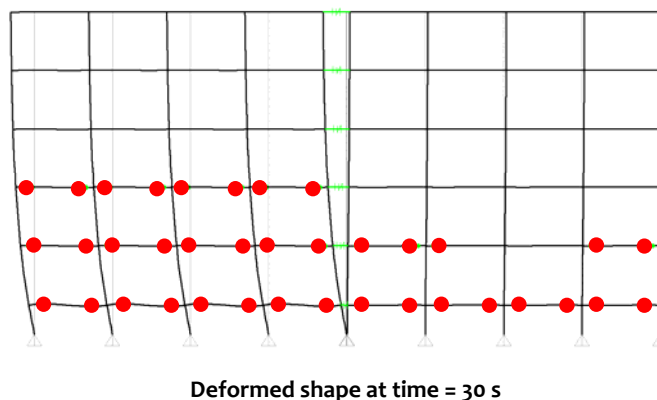


Figure 4.74: Pounding of adjoining buildings: Deformed shape of the buildings at 30s instant of ground shaking of the two identical 5-storey buildings

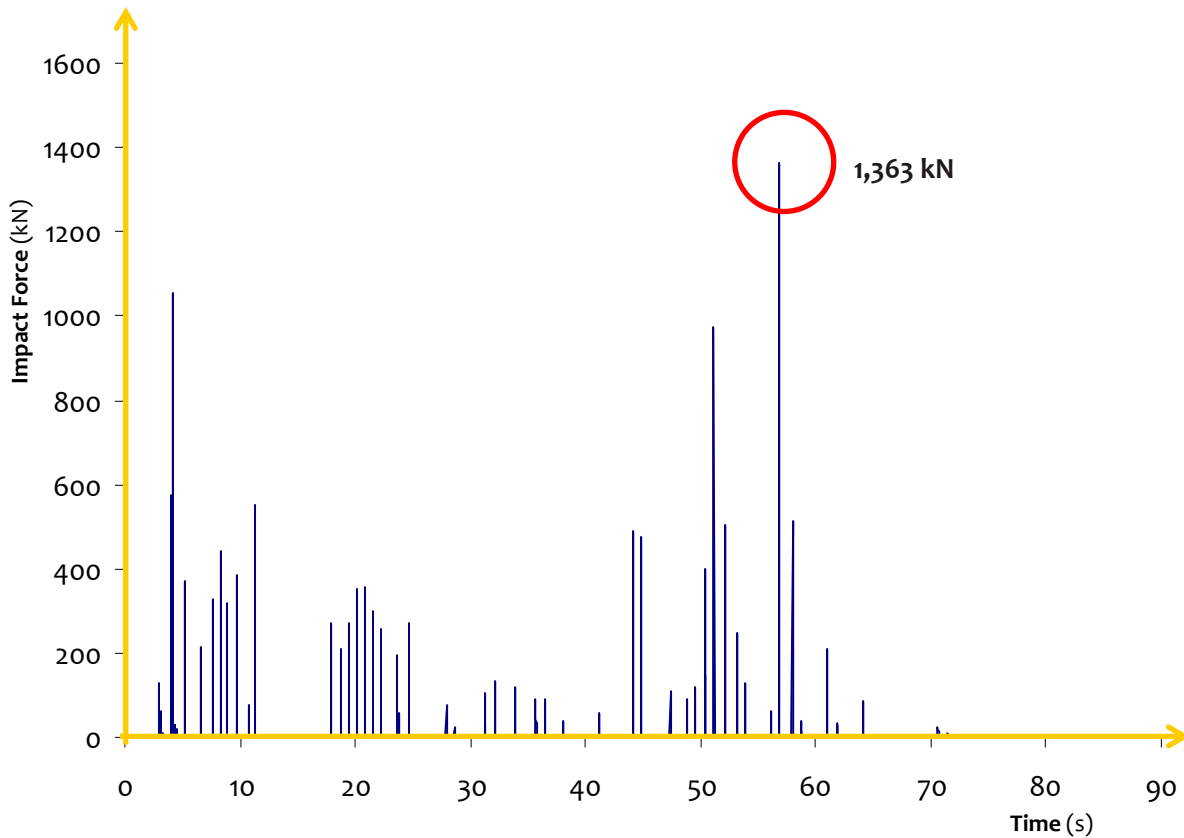


Figure 4.75: *Pounding of adjoining buildings:* Time history of impact force at one on the roof level of the buildings - (a) two identical 5-storey benchmark buildings, (b) 5-storey benchmark building and another 4-storey building, and (c) one 5-storey benchmark building and one 10-storey building.

4.4 MODELLING OF BUILDINGS

As discussed in Chapter 2, using cracked cross-section properties in RC structures significantly alters the natural period of the building. The cracked properties also affect the response of the building. The cracked building is more flexible and hence is expected to have larger deformation and lesser base shear. The overall deformability of the building as estimated from *Pushover Analysis* will be affected, only when the inelastic properties are changed. But, if the inelastic properties are the same (and as determined by the cracked properties only), only marginal change can be expected. The same cannot be said about the results from *Nonlinear Time History Analyses*.

The benchmark building is subjected to two types of analyses, namely the *Pushover Analysis* and *Time History Analyses*. As expected, *Pushover Analysis* suggests that both initial stiffness and lateral strength are smaller in building with cracked cross-section properties than those of building with gross cross-section properties (Figure 4.76). *Time History Analyses* using 1940 El Centro Earthquake ground motion (S00E component) also show expected results (Figure 4.77); overall deformation is *larger* and base shear *smaller* in the building with cracked cross-section properties.

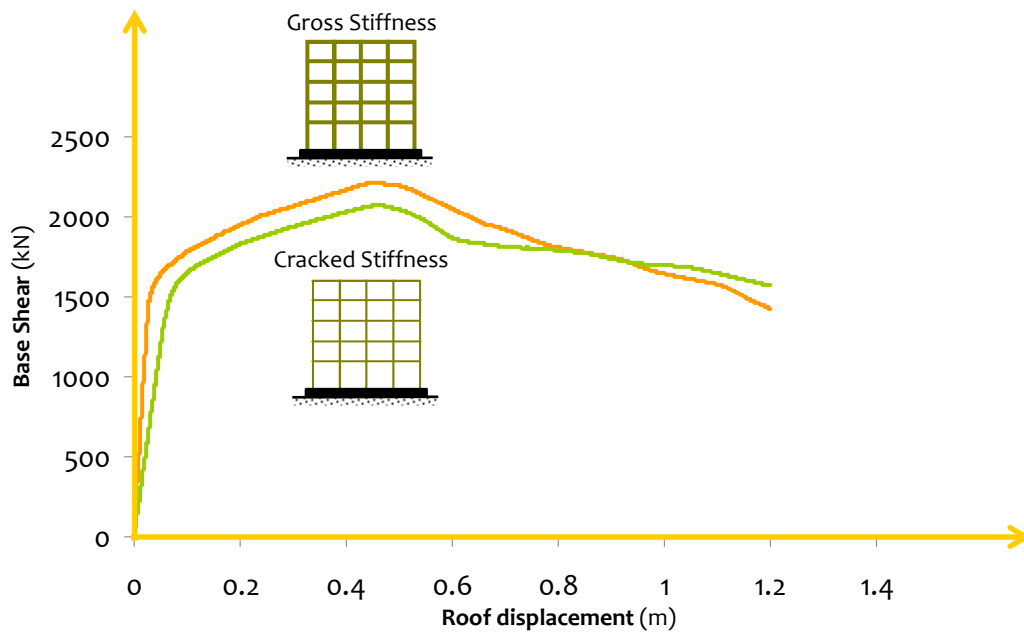
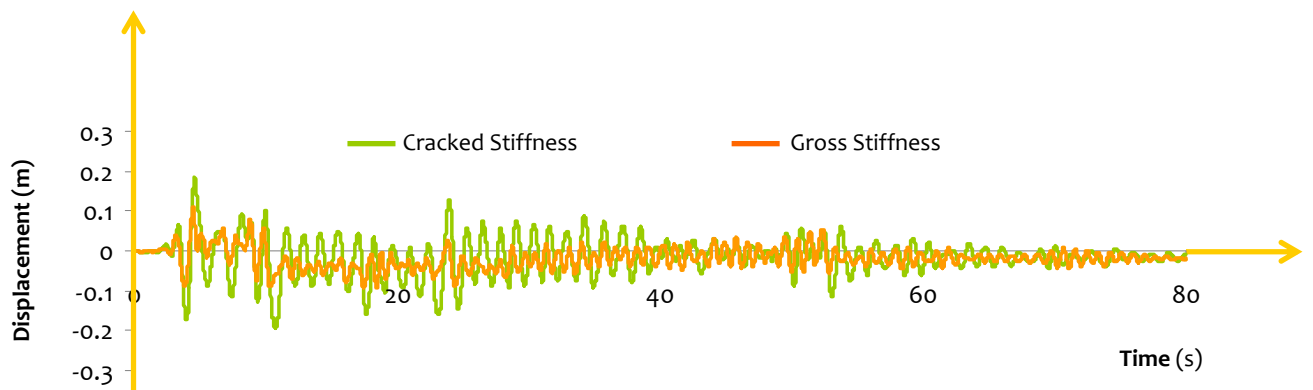
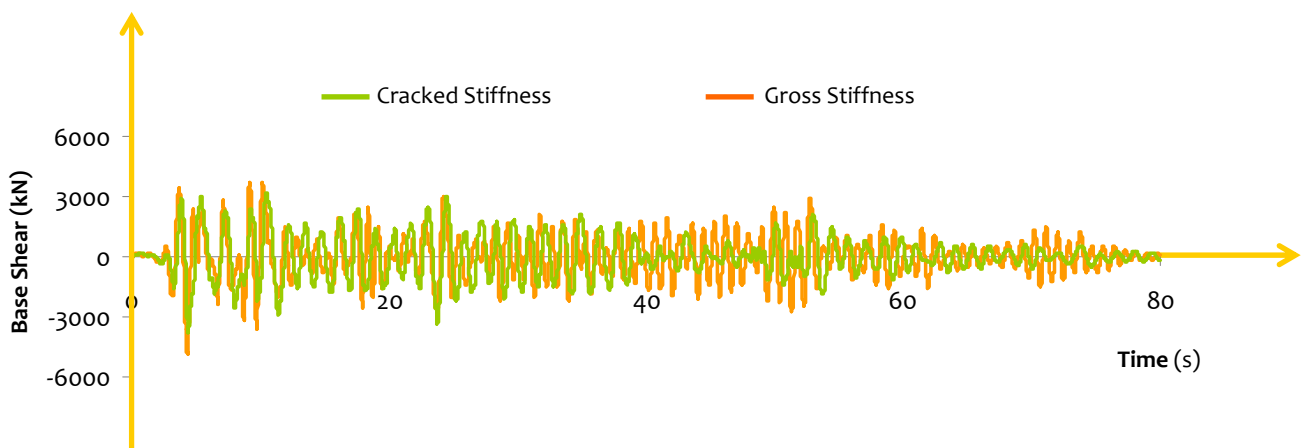


Figure 4.76: Influence of using Cracked Cross-Section Properties in RC buildings: Overall deformability is not affected



(a)



(b)

Figure 4.77: Influence of using Cracked Cross-Section Properties in RC buildings: Overall deformability is not significantly affected although base shear is reduced marginally

...

Chapter 5

Earthquake-Resistant Design of Buildings

5.1 INTRODUCTION

Buildings subjected to earthquake shaking at their base oscillate back and forth in all three directions. Under low levels of shaking, their amplitudes of shaking and directions of shaking are dependant on how they are proportioned geometrically and in terms of stiffness throughout the building in plan and elevation. Under strong earthquake shaking, buildings undergo damage also. Controlling the damage type and sequence of damage in various structural elements is the main focus of *earthquake-resistant design*. It is possible to get a reasonable understanding of the overall mechanism of failure of the building by suitable nonlinear static analysis. Many deficiencies discussed in this document can be identified at the design stage itself, and the structural configurations and design and detailing of members modified to make the building resist the earthquake effects generated in the building during strong earthquake shaking.

Displacement-controlled loading subjected at the base of the building during earthquake shaking and *inelastic actions* accrued in them during strong shaking, together make *earthquake-resistant design* of buildings exciting and special. Inter-relationships between *analysis*, *design* and *behaviour* determine the overall seismic performance of a building. These inter-relationships exist in design of buildings for other loading actions also (*e.g.*, wind, wave, snow, and temperature). But, it is the expected inelastic actions in buildings under seismic conditions and the absence of the same under other load actions, which makes *understanding earthquake behaviour of buildings* challenging. *Analysis* and *design* both influence the earthquake behaviour of buildings (Figure 5.1). *Understanding seismic behaviour* is possible only through *suitable analyses* of building that captures all behavioural actions *possible* in buildings during earthquakes. And, *controlling seismic behaviour* is possible only through *faithful design* that ensures all behavioural actions *considered* in buildings during analysis. Between design and analysis also there are relationships. For designing a new building, design should *reflect* the analysis performed, and for assessing an existing building, analysis should *assess* the design performed.

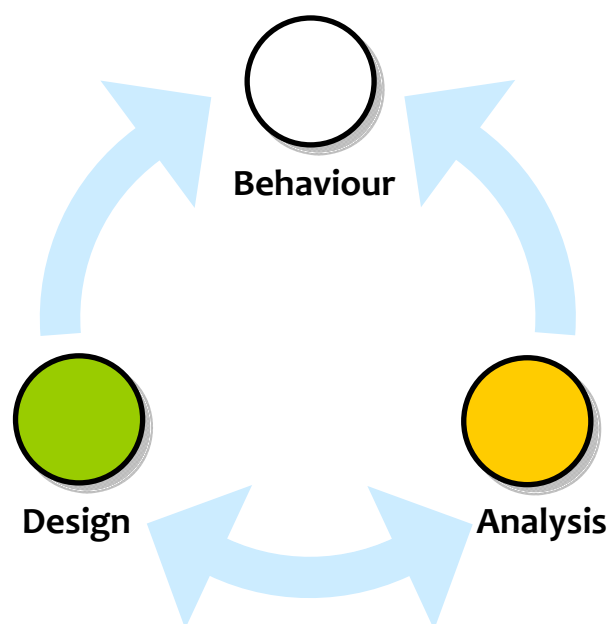


Figure 5.1: *Inter-relations that affect Earthquake-Resistant Design of Buildings:* Focus of earthquake-resistant design is desired earthquake behaviour

Thus, in earthquake-resistant design of *new buildings*, *design development process* involves (Figure 5.2):

- (1) Analysing the building to capture *desired* seismic behaviour, *i.e.*, performing suitable analyses of building to ensure *the limited expected behavioural actions ALONE* are realised in building during earthquake shaking;
- (2) Designing the building to reflect that *all assumptions made in analysis are honoured*, and thereby controlling desired seismic behaviour through design of the new building; and
- (3) Observing the building (during the next earthquake in the region where the building is built) to gain confidence in the design process or understand deficiencies in it.

But, in assessment of earthquake resistance of *existing buildings*, *safety assessment process* involves marginally separate steps (Figure 5.3) depending on whether the assessment is done after an earthquake or before it. For the pre-earthquake assessment, the steps involved are (Figure 5.3a):

- (1) Analysing the building to capture *possible* seismic behaviour, *i.e.*, performing suitable analyses of building to include *all possible behavioural actions* that can be CONCEIVED in building during earthquake shaking. Here, synthetic or recorded earthquake ground motions of *known characteristics* are employed to project the demand on the building;
- (2) Designing retrofit of each member (and thereby of the whole building) to *capture* the true behaviour that is *conceived in analysis and desired to be realized*, and thereby understanding the *likely seismic behaviour* of the existing building; and
- (3) Observing the building (during the next earthquake in the region where the building is built) to gain confidence in the retrofit design process or understand deficiencies in it.

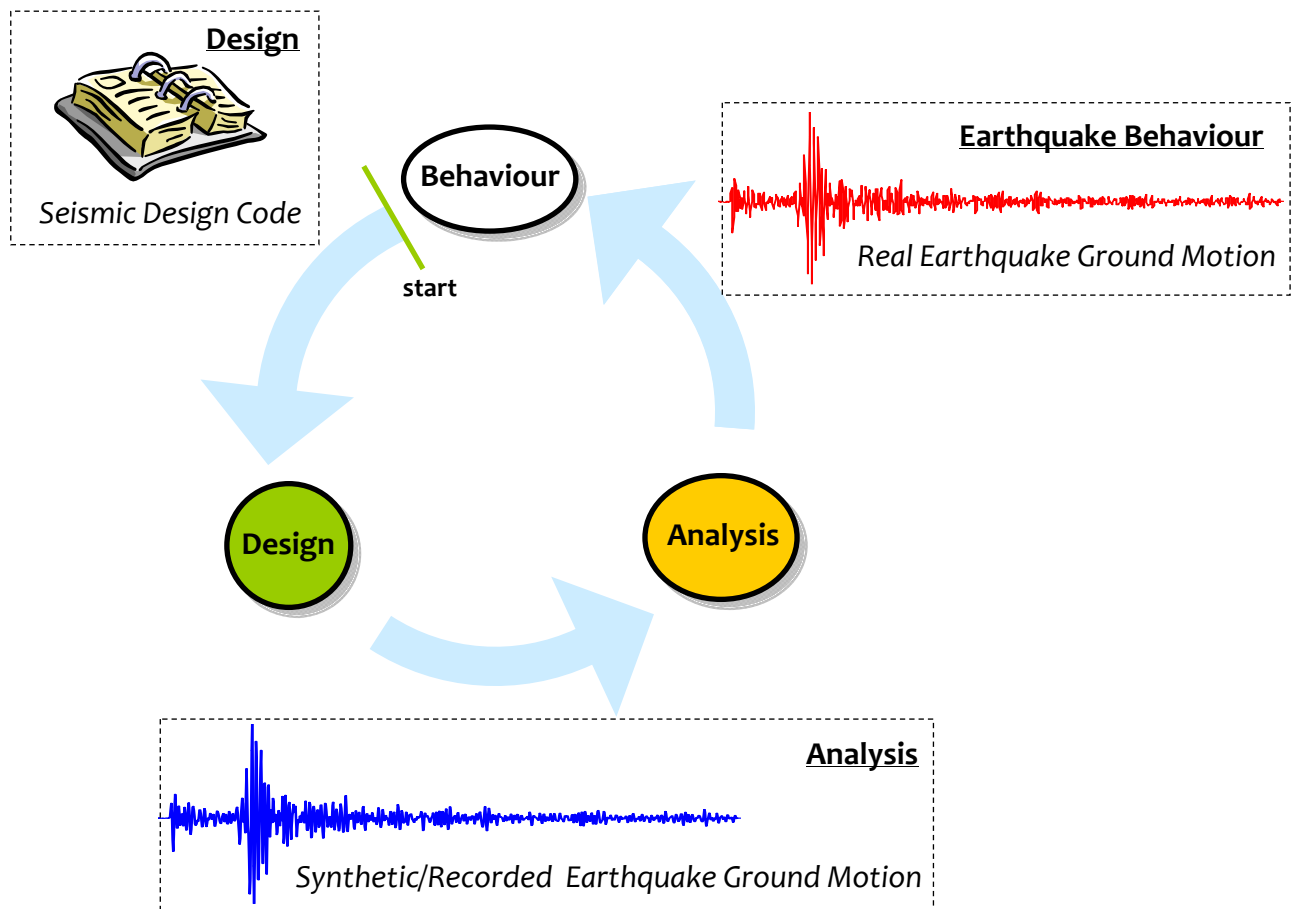
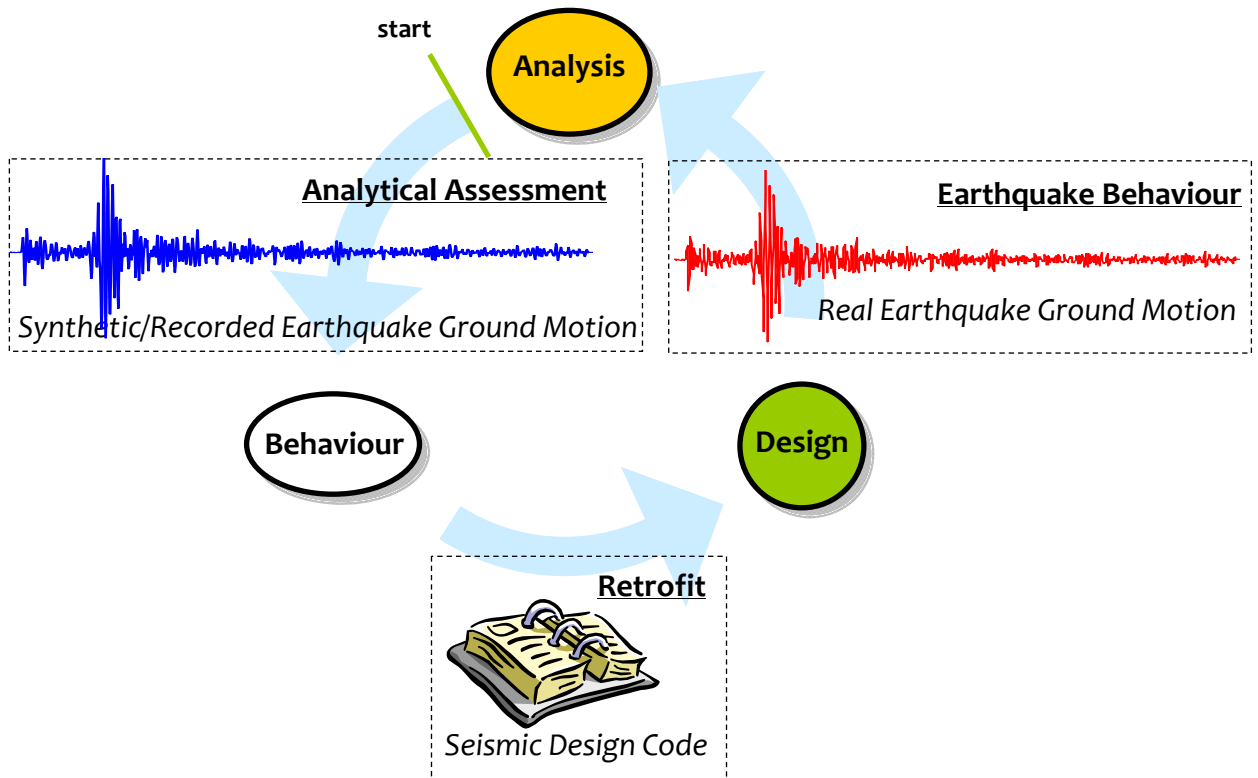


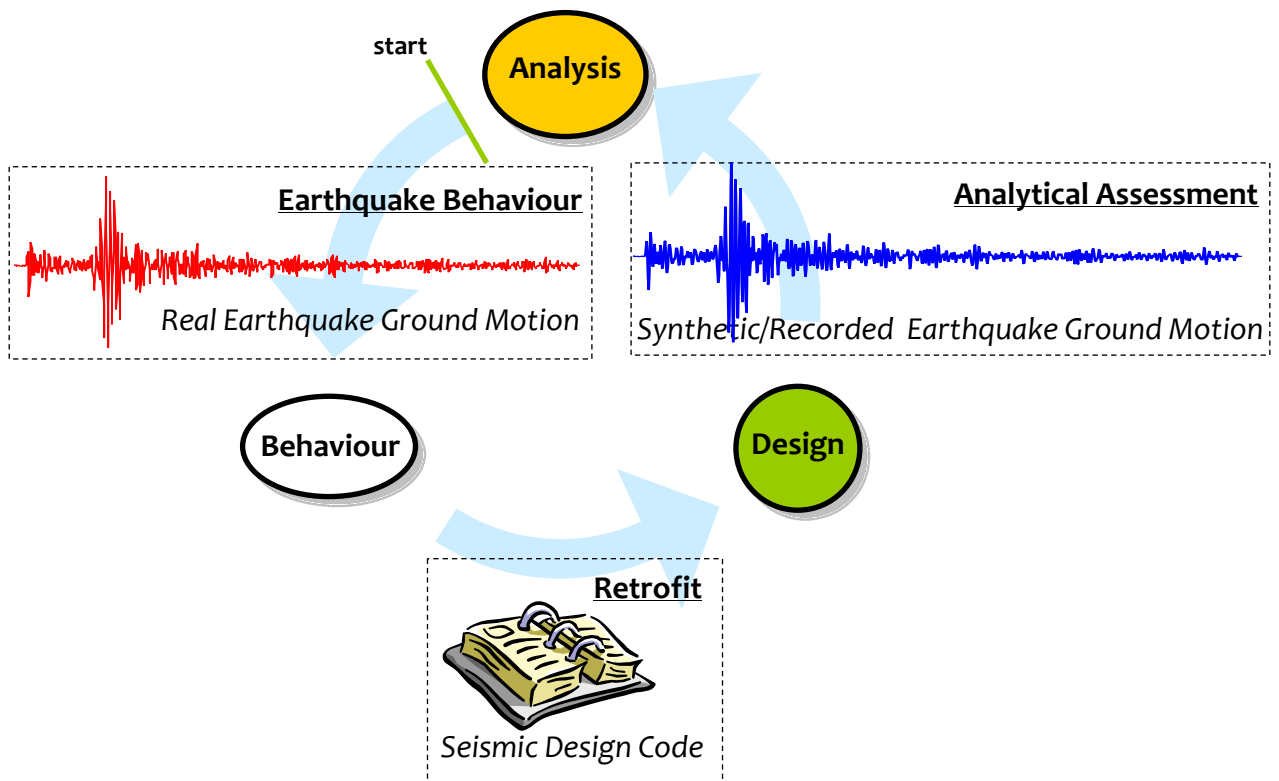
Figure 5.2: Earthquake Performance Assessment of NEW Buildings

And, for the post-earthquake assessment, the steps involved are (Figure 5.3b):

- (1) Observing the building (during the earthquake that occurred in the region where the building is built) to gain confidence in the design process or understand deficiencies in it;
- (2) Designing retrofit of each member (and thereby of the whole building) to *capture* the true behaviour that is *desired to be realized*, and thereby understanding the *likely seismic behaviour* of the existing building in the next earthquake; and
- (3) Analysing the building to capture *possible* seismic behaviour, *i.e.*, performing suitable analyses of building to include *all possible behavioural actions* that can be CONCEIVED in building during earthquake shaking. Here, synthetic or recorded earthquake ground motions of *known characteristics* are employed to project the demand on the building.



(a)



(b)

Figure 5.3: Earthquake Performance Assessment of EXISTING Buildings: (a) BEFORE Earthquake, and (b) AFTER Earthquake

5.2 EARTHQUAKE-RESISTANT DESIGN METHODS

The ideal lateral load-deformation (backbone) curve of a building under monotonic lateral displacement loading in pushover analysis reflects three clear features, namely *linear behaviour*, *onset of nonlinear behaviour* and *plastic behaviour* (Figure 5.4). These features may be used to identify three dominant ranges of structural behaviour in the sequence in which they appear, namely *elastic behaviour*, *early inelastic behaviour* and *ductile inelastic behaviour*. An important consequence of all these three characteristics together is *inelastic energy dissipation capacity* of the building.

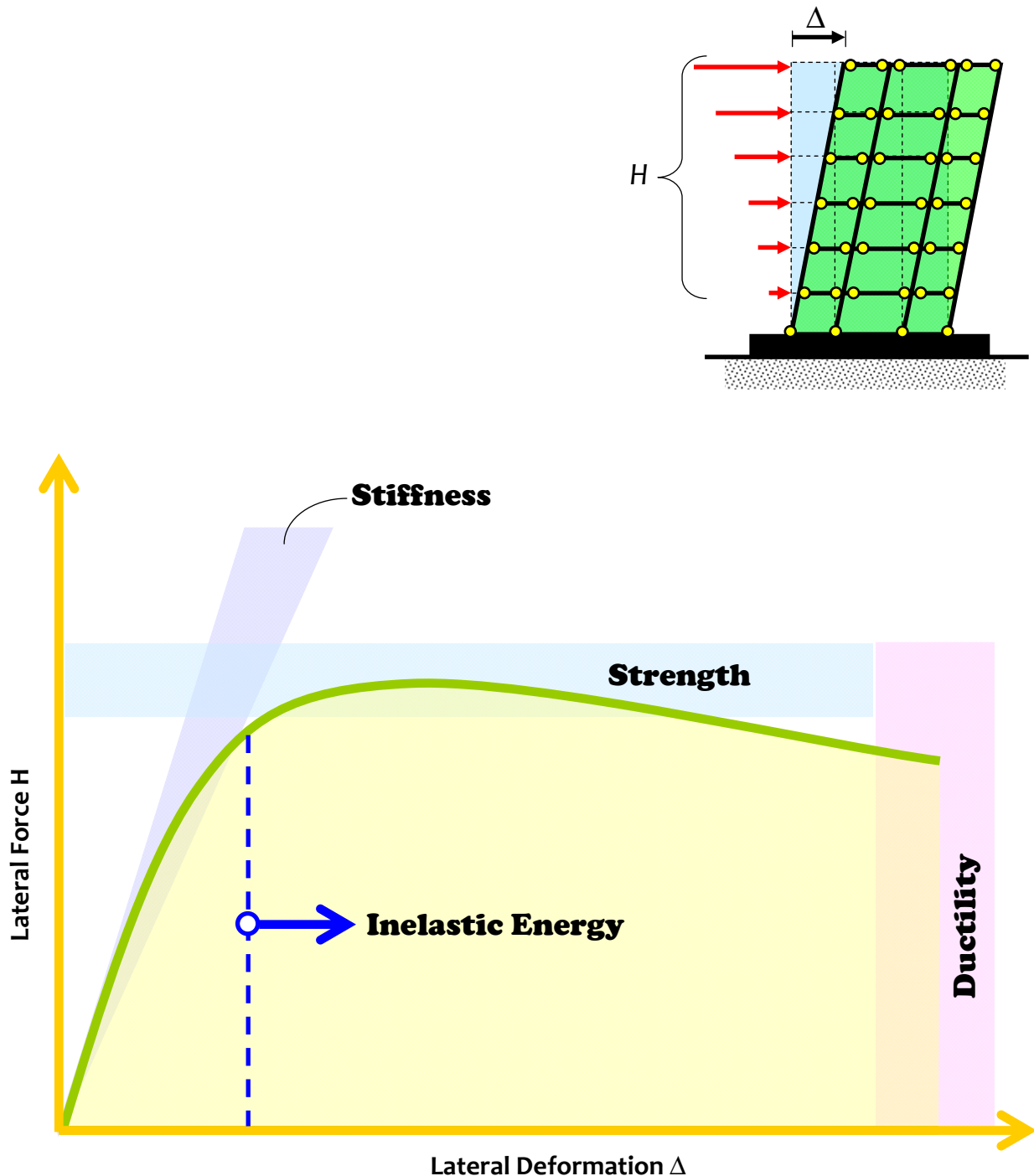
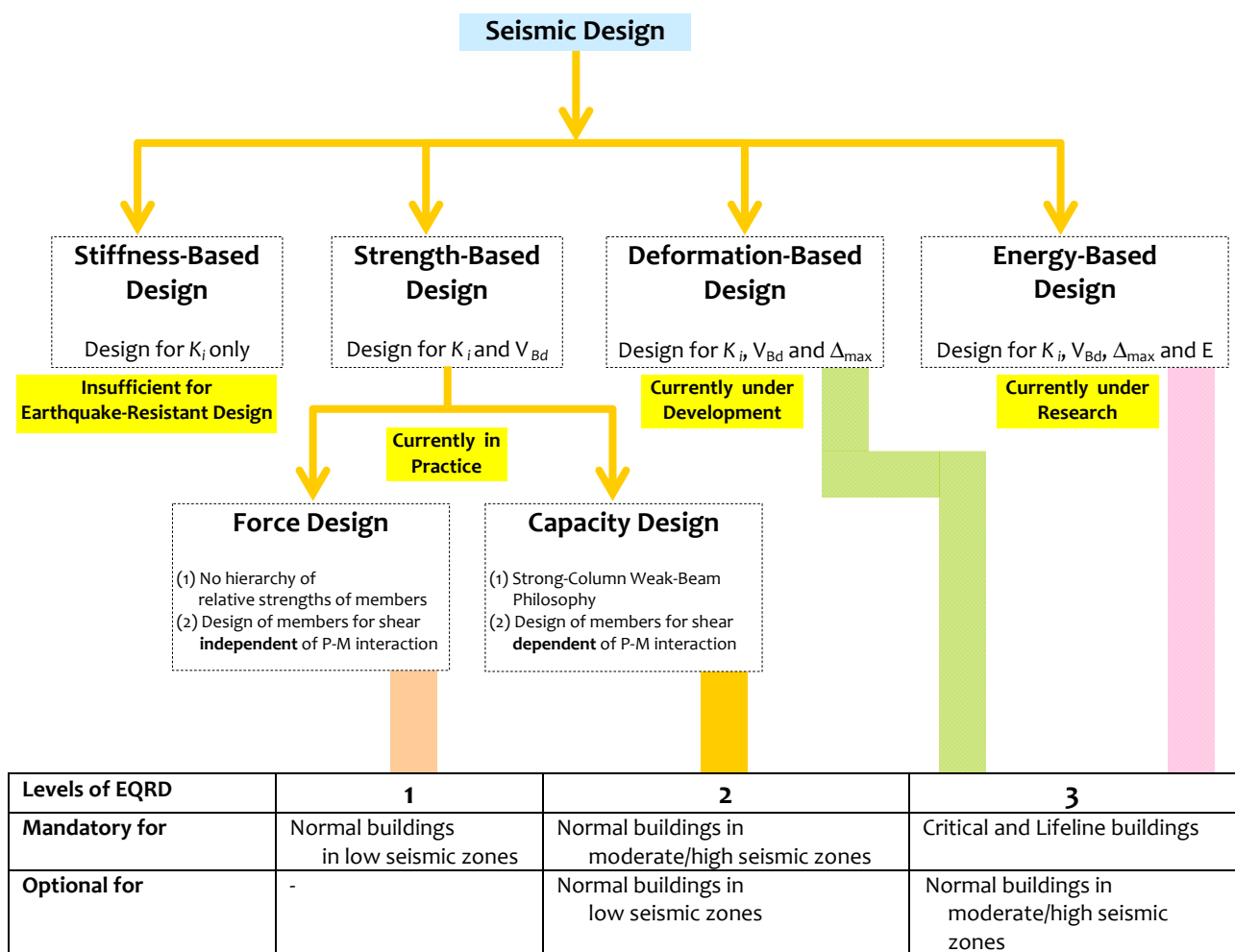


Figure 5.4: *Four Virtues of Earthquake-Resistant Buildings* control earthquake performance of buildings: *Stiffness*, *Strength* and *Ductility* directly affect load-deformation behaviour of buildings, while *Seismic Structural Configuration* affects these three virtues indirectly; *Energy Dissipation Capacity* is an overall consequence of all the four virtues of buildings

In keeping with the key characteristics of buildings (Figure 5.4), structural design of buildings can be *stiffness-based* (considering only *stiffness*), *strength-based* (considering *stiffness* and *strength*), *deformation-based* (considering *stiffness*, *strength* and *ductility*) or *energy-based* (considering *stiffness*, *strength*, *ductility* and *energy dissipation capacity*) (Figure 5.5). Strength-based design can be further classified as *Force Design* and *Capacity Design*. In the *former*, the design is based simply on the design lateral force on the building; members are designed to resist the stress-resultants obtained from linear structural analysis of the building subjected to code-specified design lateral forces. There is no pre-determined hierarchy of strengths across adjoining members and within each member. Within each member, the shear design of RC members is performed using the shear forces obtained from above structural analysis, and is *independent* of the design for axial forces and bending moments. In the *latter*, the design is based on BOTH the stress-resultants obtained from linear structural analysis of the building subjected to code-specified design lateral forces AND equilibrium-compatible stress-resultants derived from the pre-determined collapse mechanism. A pre-determined hierarchy of strengths is ensured both across adjoining members and within each member. Again within each member, the shear design of RC members is performed using larger of (a) the shear forces obtained from above structural analysis, and (b) plastic hinge based shear forces that are dependant on axial forces and bending moments.



CURRENT Earthquake Resistant Design Philosophies

Figure 5.5: Four broad methods available for Earthquake-Resistant Design: Rigour increases in each higher level method

Of the four methods of design, the *deformation-based design method* is the most advanced, and is expected to give best earthquake performance. It requires more engineering experience and judgment, but the results build more confidence in designers to arrive at a building that is more likely to perform as intended. Therefore, this method is best suited for special buildings, where earthquake performance of the building should be guaranteed, *e.g.*, critical and lifeline buildings that are required to remain functional after the earthquake. The *capacity design method* is best suited for normal buildings that are required to sustain moderate to severe seismic shaking. The *energy-based design method* is still under research. The *force design method* is known not to result in good seismic behaviour, and hence should be discouraged even in low seismic regions. But, owing to lack of adequate manpower and arguments of economy, it may be practiced for some more time.

5.3 EARTHQUAKE-RESISTANT DESIGN PROCEDURE

In keeping with the sequence in which the characteristics of buildings appear in the load-deformation behaviour of buildings (Figure 5.4), the current process of designing buildings has three stages, namely *Stiffness Design Stage*, *Strength Design Stage*, and *Ductility Design Stage*. Details are given below of steps involved in each of the three stages of seismic design of buildings.

5.3.1 Stiffness Design Stage

The main activities in this stage are:

- (1) *Choosing a seismic structural configuration*, that is expected to give desirable earthquake behaviour
 - (a) *Overall geometry* of the building of required height should be *convex*. It should be well proportioned, in keeping with elevation slenderness ratios and plan aspect ratios that have been observed in well-designed buildings. For instance, the proportioning of the building should be such that
 - (i) the maximum slenderness ratio (H/B) achieved in different well-designed buildings worldwide is generally found to be around 10, and that of maximum plan aspect ratio (L/B) to be around 4;
 - (ii) the absolute dimensions of buildings should not be unduly long to attract differential ground motion under different parts; for this a seismic wavelength analysis is required to understand the relative dimension of the building with respect to the predominant seismic wave;
 - (iii) the absolute plan area of the building should not be too large to attract large inertia force; and
 - (iv) the obvious irregularities as stated in the design codes and literature of standard should be minimised, if not entirely eliminated.
 - (b) *Structural system* chosen should be suitable for good earthquake performance, with vertical and horizontal members of lateral load resisting system (LLRS) that can carry earthquake effects safely during strong earthquake shaking. For instance, the structural system should
 - (i) be symmetrical in both directions in plan,
 - (ii) be regular in stiffness along elevation with gradually increasing stiffness towards the lower levels of the building (for instance, open ground storey buildings are unacceptable with sudden drop in lateral storey stiffness and lateral storey strength in the lower storey),
 - (iii) have many direct and short load paths, *i.e.*, the building should have large redundancy, but there should be no unexpected load paths that are not known at the time of design *e.g.*, short-column effects owing to lateral restraint offered by infills are unacceptable,
 - (iv) have no or only limited offsets in plan of the building, and
 - (v) no cut-outs in horizontal LLRS elements, *e.g.*, slabs should not have any cut-outs along their edges.

Also, just moment resisting frames may be unsuitable for resisting effects due to strong earthquake shaking in RC buildings; RC walls or braces should be used in buildings meant to be built in moderate to severe seismic zones.

This *proportioning of the building geometry* and *choosing the most suitable seismic structural configuration* is best achieved by an objective negotiation effort between the *architect* and *structural engineer* involved in the project.

(2) *Proportioning of Vertical LLRS members* in the structural system of the building

- (a) The structural plan density of vertical LLRS elements should be at least 4-8% along each direction in plan. Often, this cannot be achieved with just moment frames; structural walls are required, which run full height of the building and oriented along each plan directions.
- (b) The building should have at least a minimum amount of lateral stiffness, to ensure that deformation (and hence damage) is small under low and moderate shaking. In general, buildings with large lateral stiffness are preferred over those with small lateral stiffness.
- (c) The cross-section of each vertical member and its design (be it a structural steel or an RC column or structural wall) should be designed ideally to have the maximum axial load demand less than 30% of its uniaxial axial compression capacity.
- (d) The cross-section of each vertical column or structural wall should be such that difficulties do not arise with adjoining horizontal members in detailing of reinforcement bars in RC members and of connections in structural steel members.
- (e) The cross-section strengths of each vertical column or structural wall should be such that the vertical members are stronger than the adjoining horizontal members framing into them.

(3) *Modeling the structural system* of the building for structural analysis (on a computer)

Prepare a basic structural analysis model of the building with the dimensions and details obtained from preliminary design strategies. The analytical model of the building should

- (a) be a 3-dimensional one to be able to study dynamic behaviour, with all possible stiffness and masses of the building included in it; two-dimensional models are unacceptable, because seismic design codes require all buildings to be analysed with torsional effects with at least a minimum eccentricity between mass and stiffness at each floor level of the building; (classical literature requires that cracked moment of inertia properties be used in modeling moment frame members, *e.g.*, $0.35I_{gross}$ for beams and $0.7I_{gross}$ for columns); and
- (b) include effect of soil flexibility where the underlying soil layers are either flexible or weak; in most such cases, the associated constitutive relation of soils is nonlinear. Sometimes, even a linear idealization of the soil flexibility can reveal significantly different structural actions.

(4) *Studying dynamic modes of oscillation* of the building

This is a critical step in evaluating suitability of the overall geometry, seismic structural configuration, and distribution of mass and stiffness of the building. An important feature that should be ensured is that

- (a) The building should have minimum, if not no, asymmetry in plan. In particular, the early modes of vibration should be the *pure LATERAL TRANSLATIONAL* modes of vibration, and NOT either the *diagonal translational* or the *torsional mode(s)* of vibration that result in poor performance of the building; and
- (b) The modal mass of early pure translational modes together should account for at least 90% of the mass of the building along each plan direction of the building, excluding that of the torsional modes of vibration. If this is not being achieved, the structural configuration, member proportioning, connectivity and/or material properties need to be changed to seek the desired pure translational behaviour in the early modes of vibration.

- (5) *Performing Linear Elastic Structural Analysis* of the building
- (a) Prepare the improved structural analysis model of the building with the dimensions and details obtained from the preliminary design calculations performed above. Estimate the approximate fundamental translational natural period T_n of the building, and calculate the design seismic base shear V_B on the building by the *Equivalent Lateral Force Design* procedure (sometimes called the *Seismic Coefficient Method*).
 - (b) Apply seismic code specified design lateral forces Q_i at each floor i of the building on the analytical model of the building, perform linear elastic structural analysis, and estimate the stress-resultants from all load combinations given in the seismic code. Estimate the lateral deformation in the building, under the various load combinations. If the governing lateral deformation is within the permissible lateral deformation in the building specified in the seismic design codes, the structural configuration and sizing adopted may be accepted. Else, the vertical LLRS should be made stiffer to arrive at a revised structural configuration of the building.
 - (c) Perform *Linear Dynamic Structural Analysis* of the building for buildings that are irregular, tall, long, important and in high seismic zones. This can be done in two ways, using *recorded/synthetic ground motion time histories* or *design response spectrum*. Some codes categorically require that the *seismic base shear* from the *Response Spectrum Method* of analysis should not fall below that obtained from the *Seismic Coefficient Method*, even though the displacements estimated by the former method can exceed those by the latter.

5.3.2 Strength Design Stage

The main activities in this stage are:

- (6) *Choosing relative member flexural strength ratio* to seek desired collapse mechanism
- (a) Identify a desired collapse mechanism of the structural system in which the building should deform in, under the extreme condition of collapse, if ever, when the strong earthquake shaking exceeds the design earthquake shaking for which buildings are normally designed. Determine the locations and type of inelastic actions that are desired in the building.
 - (b) Perform *Capacity Design* of all members, to ensure strength hierarchy is such that *shear failure* is preceded by *large flexural plastic actions*, and that the plastic actions are localized to only to the desired locations as identified in step 6(a) above. In doing so, the *beam-to-column design moment strength ratio* in *moment-resisting frame buildings* or *frame-structural wall buildings* may take values much higher than those normally recommended in some seismic codes.
- (7) *Performing seismic design* of all structural elements of the building
- (a) Design the slabs of the building.
 - (b) Design each beams for *flexure* for the governing moment demand obtained from the load combinations. Then, design these beams for *shear*, by the *capacity design method* and in line with the plastic hinges in the identified desired collapse mechanism.
 - (c) Design all columns and structural walls for *flexure*, for the governing axial force and bending moment combinations specified by the seismic design code, and for the stress-resultants arising out of an additional special load combination of the building with overstrength plastic moment hinges as per identified desirable collapse mechanism. Then, design the columns for *shear*, for the shear demand from the load combinations specified by the seismic design code and for that arising out of an additional special load combination based on the capacity design method for design of shear considering the plastic hinges in beams as per identified desirable collapse mechanism. RC columns and RC walls should be designed to have all design points within the tension failure region on the P - M interaction diagram, *i.e.*, usually to have axial load demand to be about less than 30% of the uniaxial compression capacity of the section. Members of RC moment-resisting frame buildings need to have few more important features, namely:
 - (i) the column should be much wider than the beam (in both directions) to allow beam bars to be passed into/through column without cranking;

- (ii) the longitudinal bars in beams should adopt standard hook detailing at the end, to avoid constructional difficulties of anchoring beam bars into the adjoining column.
- (d) Design the beam-to-column and beam-to-wall joints to have shear stresses within the permissible values specified in seismic design code.
- (e) Design foundation(s) of the building in keeping with the capacity of the soil underneath it.

5.3.3 Ductility Design Stage

The main activities in this stage are:

- (8) *Detailing all members and their connections* to ensure ductility in required members and prevent undesired actions in other members
 - (a) Provide confining transverse reinforcement in all ductile RC beams as per the requirements specified in the seismic detailing code (including close spacing, closed loops with 135° hooks, and at least the minimum specified lengths at hook ends).
 - (b) Provide design transverse reinforcement in all RC columns and RC walls as per design calculations (including close spacing, closed loops with 135° hooks, and at least the minimum specified lengths at hook ends).
- (9) *Verifying that the desired mechanism is generated in the building*
 - (a) *Prepare the structural analysis model* for performing *nonlinear quasi-static displacement pushover analysis* (PoA) and *nonlinear time history analysis* (NL THA).
 - (b) *Perform PoA* of the building with lateral force profile as per code-specified distribution of design lateral forces. Understand the deformability under design lateral force loading and collapse mechanism generated. And, determine if the design of the building needs to be revised. If the collapse mechanism obtained is not the desirable one, revise the seismic structural configuration and repeat the above steps from step 1, till the desired mechanism is achieved. If the collapse mechanism obtained is the desirable one, go to the next step 9(c).
 - (c) *Choose a suite of ground motions* that reflect possible ground motions that are likely to occur at the location of the building. These could include far field type motions, and near-field type motions, if applicable. And, they could reflect the type of soil on which the building is constructed. Ensure that the level of their intensity and frequency spectrum are at least those specified by the seismic design code. *Perform NL THA* of the building under all ground motions identified, to capture the type of mechanism that can be generated under the building. Study the collapse mechanism generated, if any.
 - (d) If the desirable mechanism is not achieved, make suitable changes in the building in step 1 (e.g., through design of members, structural system, ductile detailing, and/or choice of materials), and perform all activities under *stiffness design* and *strength design* stages.
 - (e) If the desired mechanism is achieved, prepare requisite structural drawings as per the detailing chosen in design and analysis.

5.4 CLOSING COMMENTS

Only a select set of the concepts of earthquake behaviour is discussed in this book. This is not an exhaustive list of all concepts relevant to earthquake *behaviour, analysis* and *design*. Also, many of these concepts are inter-related; the book does not attempt to discuss these inter-relationships. It is hoped that the discussions presented in this book will help *architects* and *engineers* undertake seismic design of buildings with greater clarity and confidence, especially when using the concepts presented.

...

Bibliography

- ACI 318-08, (2008), *Building Code Requirements for Structural Concrete and Commentary*, American Concrete Institute, Farmington Hills, USA
- Ambrose,J., and Vergun,D., (1999), *Design for Earthquakes*, John Wiley & Son, Inc., USA
- Arnold,C., and Reitherman,R., (1982), *Building Configuration and Seismic Design*, John Wiley & Sons, Inc., NY, USA
- ASCE 41-06, (2007), *Seismic Rehabilitation of Existing Buildings*, American Society of Civil Engineers, USA
- Bachmann,H., (2003), *Seismic Conceptual Design of Buildings – Basic principles for engineers, architects, building owners, and authorities*, BBL Vertrieb Publikationen, Bern
- Charney,F.A., (1998), *NONLIN Program – educational program for learning the concepts of Structural Dynamics and Earthquake Engineering*, FEMA Training Center, and Advanced Structural Concepts, USA, <http://www.app1.fema.gov/emi/nonlin.htm>
- Chopra,A.K., (1982), *Dynamics of Structures A Primer*, Earthquake Engineering Research Institute, Oakland, California, USA
- Chopra,A.K., (2012), *Dynamics of Structures – Theory and Application to Earthquake Engineering*, Fourth Edition, Prentice Hall Inc, USA
- CSI, (2010), *Structural Analysis Program (SAP) 2000*, Version 14, Computers and Structures Inc., USA
- Das,B.M., *Principles of Foundation Engineering*, 7th Ed., Cengage Learning, Stamford, CT, USA
- Dowrick,D.J., (1987), *Earthquake Resistant Design for Engineers and Architects*, 2nd Ed., John Willey & Sons, NY, USA
- FIB, (2003), *Displacement-based Seismic Design of Reinforced Concrete Buildings*, State-of-the-Art Report Prepared by Task Group 7.2, International Federation for Structural Concrete (fib), Switzerland
- Goel,S.C., and Chao,S.H., (2008), *Performance-Based Plastic Design Earthquake Resistant Steel Structures*, International Code Council, IL, USA
- Housner,G.W., and Jennings,P.C., (1982), *Earthquake Design Criteria*, Earthquake Engineering Research Institute, Oakland, California, USA
- IITK-GDMA, (2005), *IITK-GSDMA Guidelines for Proposed Draft Code and Commentary on Indian Seismic Code IS:1893 (Part 1)*, IITK-GSDMA-EQ05-V4.0, August 2005, Indian Institute of Technology Kanpur and Gujarat State Disaster Mitigation Authority, Gandhinagar, India
- IS:13920, (1993), *Indian Standard Code of Practice for Ductile Detailing of Reinforced Concrete Structures Subjected to Seismic Forces*, Bureau of Indian Standards, New Delhi
- IS:1893 (Part 1), (2007), *Indian Standard Criteria for Earthquake Resistant Design of Structures*, Bureau of Indian Standards, New Delhi
- IS:456, (2000), *Indian Standard Code of Practice for Plain and Reinforced Concrete*, Bureau of Indian Standards, New Delhi
- Kaushik,H.B. (2006), “Evaluation of strengthening options for masonry-infilled RC frames with open first-storey”, *Ph.D. Thesis*, Department of Civil Engineering, Indian Institute of Technology Kanpur, India
- Dasgupta,K., (2009), “Improvement in Geometric Design of Reinforced Concrete Structural Walls to Resist Earthquake Effects,” *Ph.D. Thesis*, Department of Civil Engineering, Indian Institute of Technology Kanpur, India
- Kramer,S.L., (1996), *Geotechnical Earthquake Engineering*, Prentice Hall, NJ, USA
- Murty,C.V.R., (2005), *IITK-BMTPC Earthquake Tips - Learning Earthquake Design and Construction*, National Information Center of Earthquake Engineering, IIT Kanpur, India
- Murty,C.V.R., Chrlson,A.W., and Sanyal,S.A., (2006), *Earthquake Design Concepts*, Teaching Resource Material for Teachers of Architecture Colleges, National Information Center of Earthquake Engineering, IIT Kanpur, India
- Naeim,F. (Ed.), (2001), *The Seismic Design Handbook*, Kluwer Academic Publishers, Boston, USA
- Newmark, N.M., and Hall,W.J., (1982), *Earthquake Spectra and Design*, Earthquake Engineering Research Institute, Oakland, California, USA
- Newmark,N.M., and Rosenblueth,E., (1971), *Fundamentals of Earthquake Engineering*, Prentice Hall, NJ, USA
- Park,R., and Paulay,T., (1975), *Reinforced Concrete Structures*, John Wiley and Sons, Inc., NY, USA
- Paulay,T., and Priestley,M.J.N., (1992), *Seismic Design of Reinforced Concrete and Masonry Buildings*, John Wiley, USA
- Penelis,G.G., and Kappos, A.J., (1997), *Earthquake-Resistant Concrete Structures*, E & FN Spon
- Poulos,H.G., and Davis,E.H., (1980), *Pile Foundation Analysis and Design*, John Wiley & Sons, Inc., NY, USA

- Priestley,M.J.N., Seible,F., and Calvi,G.M., (1996), *Seismic Design and Retrofit of Bridges*, John Wiley & Sons Inc, USA
- Reynolds,C.E., Steedman,J.C., and Threlfall,A.J., *Reynold's Reinforced Concrete Designer's Handbook*, 11th Edition, Taylor and Francis, London, UK
- Stratta,J.L., (2003), *Manual of Seismic Design*, Pearson Education, First Indian Reprint
- Taranath,B.S., (2012), *Structural Analysis and Design of Tall Buildings – Steel and Composite Construction*, CRC Press, USA
- Taranath,B.S., (2011), *Reinforced Concrete Design of Tall Buildings*, CRC Press, USA
- Towhata,I., (2008), *Geotechnical Earthquake Engineering*, Springer, Heidelberg, Germany

...

